

SVL259 LED

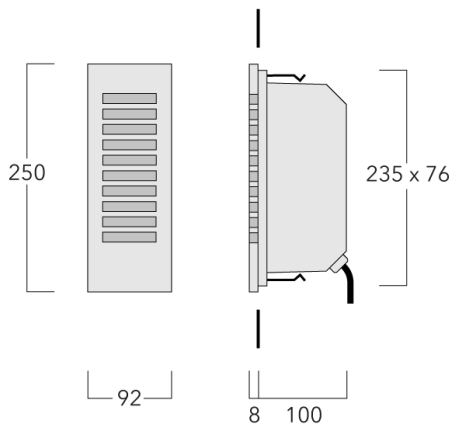



Wall luminaires recessed



Description

IP55, Class I. IK10. Marine-grade, die-cast aluminium alloy. 5CE superior corrosion protection including PCS hardware. Polycarbonate lens. Silicone rubber gasket. Integral EC electronic converter. Advanced thermal management protects LEDs while optimising lumens output. Two cable entries. Pre-installation blockout is recommended for mounting in concrete, available on request.

Wall luminaires recessed**Specifications****Material description**

Body	Marine-grade die-cast aluminium alloy
Lens	Polycarbonate lens
Colours	 RAL9004 Signal black  RAL9007 Grey aluminium  RAL7016 Anthracite grey  RAL9016 Traffic white
Gasket	Silicone rubber gasket
Fasteners	PCS hardware
Ingress protection	IP55
Impact resistance	IK10
Corrosion resistance	5CE

Electrical description

Power supply	220-240V / 50-60 Hz
Driver / Ballast	Integral EC electronic converter

Additional information

Lifetime	Ta=25° L80B10 > 54000h
----------	------------------------

SVL259 LED

Wall luminaires recessed

we-ef

Options

Light distribution Colour temperature Nominal Watt

SVL259 LED

Wall luminaires recessed



Configurations

Light distribution	Part ID	Light source	Rated lumens	Rated input power	CRI	Weight (kg)
--------------------	---------	--------------	--------------	-------------------	-----	-------------

WE-EF LIGHTING (Thailand) Co., Ltd.

57 Moo 5, Kingkaew Rd., Bangplee, 10540 Samutprakarn - Phone: +66 2 738 96 20 - Fax: +66 2 738 96 29

<https://we-ef.com/asia>

Subject to technical changes and errors. - Generated on 23/11/2024

Mounting Accessories

Installation blackout

Description	Part ID	A	B	C1
Installation blackout BST25-II	133-0078	267	132	140

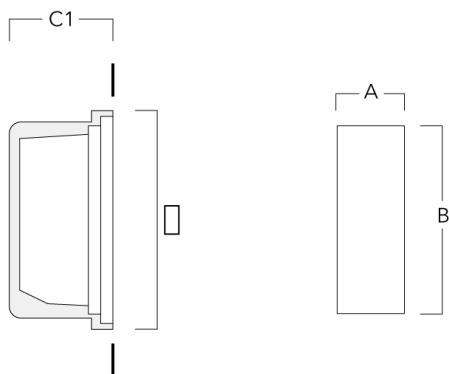

Installation blackout BST25-I	133-0076	267	132	130
-------------------------------	----------	-----	-----	-----

