



WE-EF LIGHTING USA, LLC

410-D Keystone Drive, 15086 Warrendale, PA 15086 - Phone: +1 724 742 0030

customersupport.usa@we-ef.com - <https://we-ef.com/us>

Subject to technical changes and errors. - Generated on 10/23/2024

ETC119 LED

Inground Luminaires

we-ef

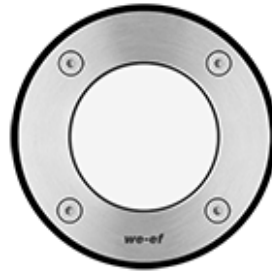

WE-EF LIGHTING USA, LLC

410-D Keystone Drive, 15086 Warrendale, PA 15086 - Phone: +1 724 742 0030

customersupport.usa@we-ef.com - <https://we-ef.com/us>

Subject to technical changes and errors. - Generated on 10/23/2024

ETC119 LED

Inground Luminaires

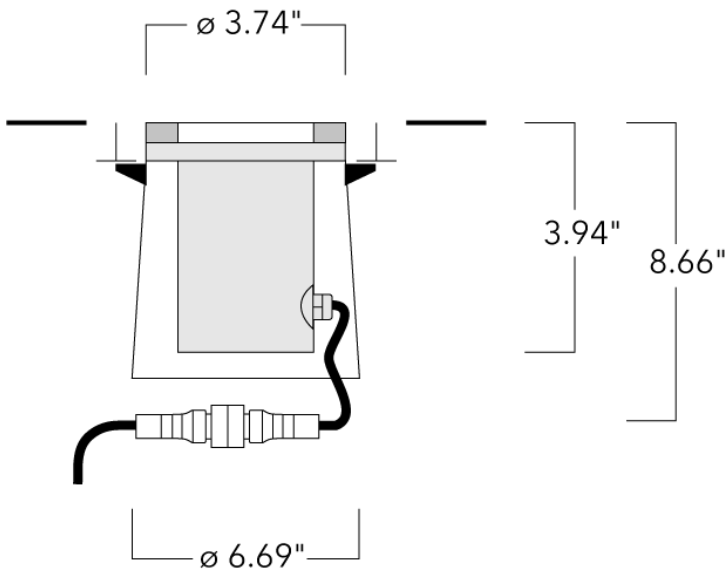

Description

IP67. 12V - 24V AC/DC. Class III. IK09. Stainless steel construction. PCS hardware. Silicone CCG® Controlled Compression Gasket. Safety glass lens. Luminaire can be driven over at low speed. Factory-sealed termination chamber complete with cable gland and 3 ft of flexible PVC-free cable. Driver required; to be ordered separately. Factory-installed LED circuit board. LED boards can be easily removed for upgrading.

Suitable for flush installation in concrete or earth. Deep concrete-pour installation blockout supplied as standard with luminaire.

IP68 in-line connector facilitates easy removal for off-site lamp replacement.

Specify product with 7 Digit product code - Finish Color. Accessories, such as mounting, optical, and electrical, must be specified separately.

Example: XXX-XXXX-9004 (Black)
+ XXX-XXXX (Accessory 1)

WE-EF LIGHTING USA, LLC

410-D Keystone Drive, 15086 Warrendale, PA 15086 - Phone: +1 724 742 0030

customersupport.usa@we-ef.com - <https://we-ef.com/us>

Subject to technical changes and errors. - Generated on 10/23/2024

ETC119 LED

Inground Luminaires

Specifications

Material description

Body	Luminaire body constructed of stainless steel. Outer housing composite material.
Lens	Tempered glass lens with internal white ceramic glazing. Max. load 5 tonnes.
Colors	 Stainless Steel
Gasket	Silicone rubber gasket
Fasteners	PCS polymer coated stainless steel
Ingress protection	IP67
Impact resistance	IK09

Electrical description

Power supply	Requires remote [RT] mounted 120-24 volt DC Class 2 LED power supply. To be ordered separately.
Driver / Ballast	Electronic converter required. To be ordered separately.
Termination	Factory sealed termination chamber

Additional information

Lifetime	Ta=25°/40° L90B10 > 90000h
Listings	Contact WE-EF USA for ETL/UL certification status.

WE-EF LIGHTING USA, LLC

410-D Keystone Drive, 15086 Warrendale, PA 15086 - Phone: +1 724 742 0030

customersupport.usa@we-ef.com - <https://we-ef.com/us>

Subject to technical changes and errors. - Generated on 10/23/2024

ETC119 LED

Inground Luminaires

we-ef

Options

Light distribution Color temperature Nominal Watt

WE-EF LIGHTING USA, LLC

410-D Keystone Drive, 15086 Warrendale, PA 15086 - Phone: +1 724 742 0030

customersupport.usa@we-ef.com - <https://we-ef.com/us>

Subject to technical changes and errors. - Generated on 10/23/2024

ETC119 LED

Inground Luminaires



Configurations

Light distribution	Part ID	Light source	Rated lumens	Rated input power	CRI	Weight (lb)
--------------------	---------	--------------	--------------	-------------------	-----	-------------

WE-EF LIGHTING USA, LLC

410-D Keystone Drive, 15086 Warrendale, PA 15086 - Phone: +1 724 742 0030

customersupport.usa@we-ef.com - <https://we-ef.com/us>

Subject to technical changes and errors. - Generated on 10/23/2024

ETC119 LED

Inground Luminaires



Mounting Accessories

Installation blackout

Description	Part ID	D1	D2	H1	Weight (lb)	D	H
Blockout, Plastic	185-0412	3.74	9.45	4.33	1.1	95/240	110

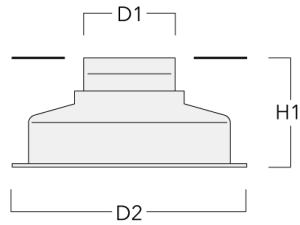

WE-EF LIGHTING USA, LLC

410-D Keystone Drive, 15086 Warrendale, PA 15086 - Phone: +1 724 742 0030

customersupport.usa@we-ef.com - <https://we-ef.com/us>

Subject to technical changes and errors. - Generated on 10/23/2024

Electrical Accessories**Sealable junction box**

Description	Part ID	C1	M1	M2
Sealable junction box SJB 130	185-1624	5.75	Ø 0.39	Ø 0.47 - 0.75

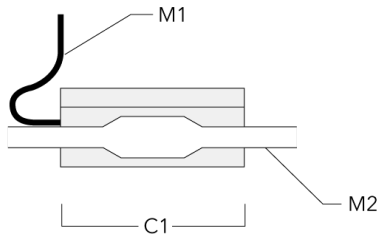
**Transformers**

Description	Part ID
Transformer 120 V - 24 V DC 17.0W	697-9415
Transformer 120 V - 24 V DC 5.6W - 40.8W	697-9416
Transformer 120 V - 24 V DC 0.7W - 100.0W	697-9417

WE-EF LIGHTING USA, LLC

410-D Keystone Drive, 15086 Warrendale, PA 15086 - Phone: +1 724 742 0030

customersupport.usa@we-ef.com - <https://we-ef.com/us>

Subject to technical changes and errors. - Generated on 10/23/2024

ETC119 LED
Inground Luminaires

WE-EF LIGHTING USA, LLC

410-D Keystone Drive, 15086 Warrendale, PA 15086
Phone: +1 724 742 0030

customersupport.usa@we-ef.com
<https://we-ef.com/us>

Subject to technical changes and errors.
Generated on 10/23/2024