

## BSP544 LED

Pole mounted

**we-ef**

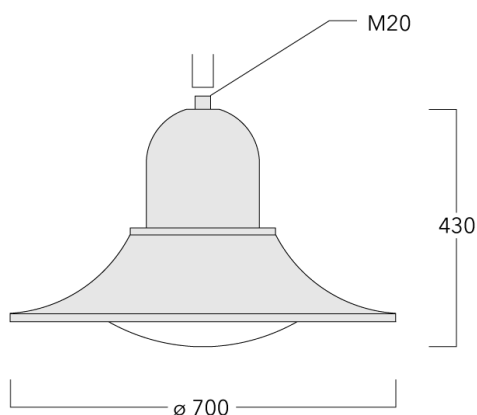

### Description

IP55, Class I. IK10. Marine-grade, die-cast aluminium alloy. 5CE superior corrosion protection including PCS hardware. Silicone rubber gasket. Polycarbonate main lens. Integral EC electronic converter in thermally separated compartment. CAD-optimised optics for superior illumination and glare control. OLC® One LED Concept. Factory installed LED circuit board. The luminaire is factory-sealed and does not need to be opened during installation. Optional 2200 K version available. To be specified at time of ordering.

Brackets to be ordered separately.

### WE-EF LIGHTING Pty Ltd

6/13 Downard Street, 3195 Braeside, Victoria - Phone: +61 3 8587 0444 - Fax: +61 3 8587 0499

info.australia@we-ef.com - <https://we-ef.com/aus>

Subject to technical changes and errors. - Generated on 23/11/2024



# BSP544 LED

Pole mounted

## Specifications

### Material description

---

|                      |   |
|----------------------|---|
| Body                 | Marine-grade, die-cast aluminium alloy  |
| Lens                 | Polycarbonate lens  |
| Colours              |  RAL9004 Signal black<br> RAL9006 White aluminium<br> RAL9007 Grey aluminium |
| Gasket               | Silicone rubber gasket  |
| Fasteners            | PCS Polymer Coated Stainless Steel Hardware   |
| Ingress protection   | IP55  |
| Impact resistance    | IK10  |
| Corrosion resistance | 5CE   |
| Windage              | 0.1246 m <sup>2</sup>   |

---

### Electrical description

---

|                  |                                  |
|------------------|----------------------------------|
| Power supply     | 220-240V / 50-60 Hz              |
| Driver / Ballast | Integral EC electronic converter |
| Power factor     | > 0.9                            |

---

### Additional information

---

|          |                        |
|----------|------------------------|
| Lifetime | Ta=40° L90B10 > 90000h |
|----------|------------------------|

---

# BSP544 LED

Pole mounted

## Options

### Light distribution



asymmetric, side throw [S65]



rectangular, side throw [R65]

### Colour temperature



2700 K

### Nominal Watt

58 W

86 W

# BSP544 LED

Pole mounted

**we-ef**

## Configurations

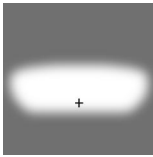
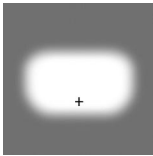
| Light distribution  | Part ID  | Light source                 | Rated lumens | Rated input power | CRI | Weight (kg) |
|---|----------|------------------------------|--------------|-------------------|-----|-------------|
| asymmetric, side throw [S65]<br>  | 127-1433 | LED-24/48W / 700 mA - 2700 K | 5512.6       | 54 W              | 80  | 13.10       |
|   | 127-1434 | LED-36/72W / 700 mA - 2700 K | 8268.9       | 79 W              | 80  | 13.10       |
| rectangular, side throw [R65]<br> | 127-1435 | LED-24/48W / 700 mA - 2700 K | 5026.5       | 54 W              | 80  | 13.10       |
|   | 127-1436 | LED-36/72W / 700 mA - 2700 K | 7539.8       | 79 W              | 80  | 13.10       |

### WE-EF LIGHTING Pty Ltd

6/13 Downard Street, 3195 Braeside, Victoria - Phone: +61 3 8587 0444 - Fax: +61 3 8587 0499

info.australia@we-ef.com - <https://we-ef.com/aus>

Subject to technical changes and errors. - Generated on 23/11/2024

# BSP544 LED

Pole mounted

## Control

### Eco Step Dim® Basic

| Description             | Part ID  |
|-------------------------|----------|
| Eco Step Dim® Basic LED | 430-0001 |

### Eco Step Dim® Advanced

| Description                | Part ID  |
|----------------------------|----------|
| Eco Step Dim® Advanced LED | 430-0002 |

**Mounting Accessories****Wall and pole brackets BA**

| Description                  | Part ID  | C1  | D x L1 | H1   | H2  | M1 | Weight (kg) | C   | H    |
|------------------------------|----------|-----|--------|------|-----|----|-------------|-----|------|
| BA0-580 Wall bracket, single | 300-0149 | 635 |        | 1000 | 132 | 9  | 2.50        | 635 | 1000 |

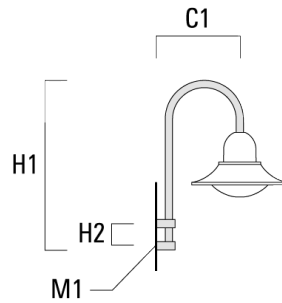

|                              |          |     |         |      |  |  |      |     |      |
|------------------------------|----------|-----|---------|------|--|--|------|-----|------|
| BA1-580 Pole bracket, single | 300-0089 | 580 | 76 x 80 | 1000 |  |  | 4.50 | 580 | 1000 |
|------------------------------|----------|-----|---------|------|--|--|------|-----|------|

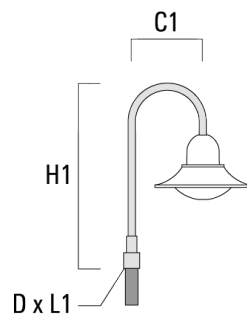

# BSP544 LED

## Pole mounted

| Description                  | Part ID  | C1  | D x L1  | H1   | H2 | M1 | Weight (kg) | C   | H    |
|------------------------------|----------|-----|---------|------|----|----|-------------|-----|------|
| BA2-580 Pole bracket, double | 300-0090 | 675 | 76 x 80 | 1000 |    |    | 8.50        | 675 | 1000 |

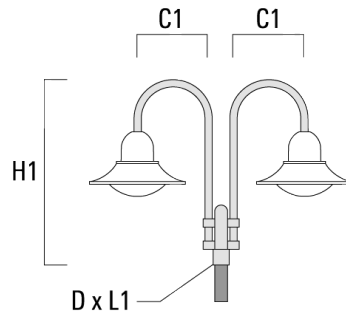

|                              |          |     |         |      |  |  |       |     |      |
|------------------------------|----------|-----|---------|------|--|--|-------|-----|------|
| BA3-580 Pole bracket, triple | 300-0093 | 675 | 76 x 80 | 1000 |  |  | 10.50 | 675 | 1000 |
|------------------------------|----------|-----|---------|------|--|--|-------|-----|------|

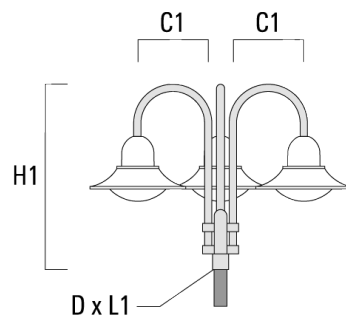

**Wall and pole brackets BC**

| Description                  | Part ID  | C1  | H1   | H2  | M1 | Weight (kg) | C   | H    |
|------------------------------|----------|-----|------|-----|----|-------------|-----|------|
| BC0-580 Wall bracket, double | 300-0771 | 635 | 1325 | 300 | 8  | 2.80        | 635 | 1325 |

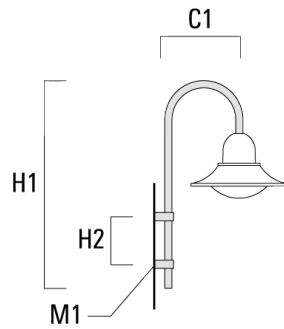

|                              |          |     |      |     |   |      |     |      |
|------------------------------|----------|-----|------|-----|---|------|-----|------|
| BC1-580 Pole bracket, single | 300-0770 | 675 | 1325 | 300 | 8 | 2.80 | 675 | 1325 |
|------------------------------|----------|-----|------|-----|---|------|-----|------|

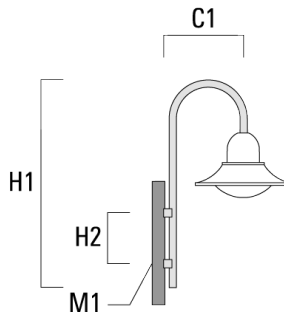



# BSP544 LED

## Pole mounted

| Description                  | Part ID  | C1  | H1   | H2  | M1 | Weight (kg) | C   | H    |
|------------------------------|----------|-----|------|-----|----|-------------|-----|------|
| BC2-580 Pole bracket, double | 300-0769 | 675 | 1325 | 300 | 8  | 5.60        | 675 | 1325 |

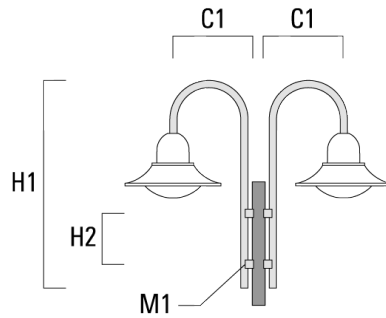

## Wall and pole brackets DA

| Description                  | Part ID  | C1  | C2 | D × L1 | H1  | Weight (kg) | C   | H   |
|------------------------------|----------|-----|----|--------|-----|-------------|-----|-----|
| DA0-750 Wall bracket, single | 300-0086 | 720 | 70 |        | 950 | 7.30        | 720 | 950 |

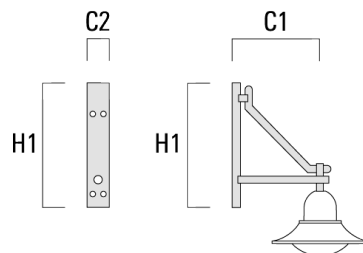

# BSP544 LED

## Pole mounted

| Description                  | Part ID  | C1  | C2 | D x L1   | H1  | Weight (kg) | C   | H   |
|------------------------------|----------|-----|----|----------|-----|-------------|-----|-----|
| DA1-750 Pole bracket, single | 300-0083 | 720 |    | 76 x 130 | 950 | 7.30        | 720 | 950 |

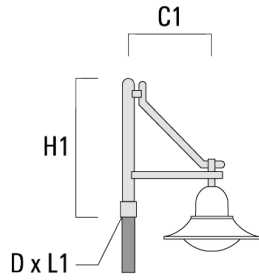

|                              |          |     |  |          |     |       |     |     |
|------------------------------|----------|-----|--|----------|-----|-------|-----|-----|
| DA2-750 Pole bracket, double | 300-0084 | 720 |  | 76 x 130 | 950 | 10.60 | 720 | 950 |
|------------------------------|----------|-----|--|----------|-----|-------|-----|-----|

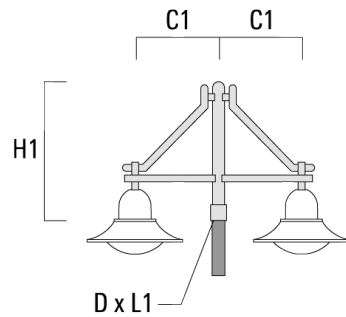

# BSP544 LED

## Pole mounted

| Description                  | Part ID  | C1  | C2 | D x L1   | H1  | Weight (kg) | C   | H   |
|------------------------------|----------|-----|----|----------|-----|-------------|-----|-----|
| DA3-750 Pole bracket, triple | 300-0085 | 720 |    | 76 x 130 | 950 | 13.90       | 720 | 950 |

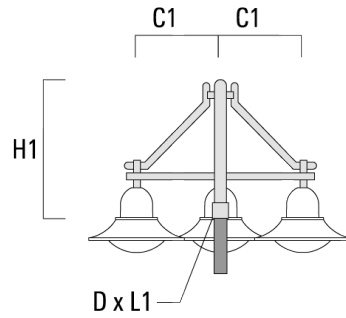

## Wall and pole brackets DB

| Description                  | Part ID  | C1  | C2 | D x L1 | H1  | Weight (kg) | C   | H   |
|------------------------------|----------|-----|----|--------|-----|-------------|-----|-----|
| DB0-750 Wall bracket, single | 300-0172 | 720 | 70 |        | 950 | 7.10        | 720 | 950 |

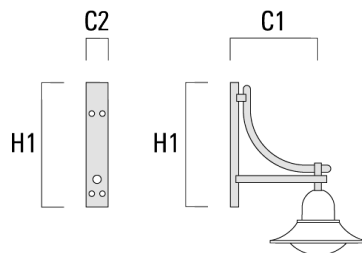

# BSP544 LED

## Pole mounted

| Description                  | Part ID  | C1  | C2 | D x L1   | H1  | Weight (kg) | C   | H   |
|------------------------------|----------|-----|----|----------|-----|-------------|-----|-----|
| DB1-750 Pole bracket, single | 300-0165 | 720 |    | 76 x 130 | 950 | 7.10        | 720 | 950 |

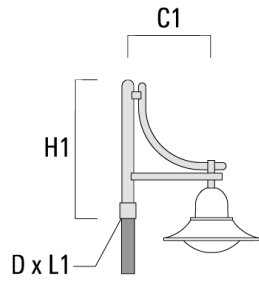

|                              |          |     |  |          |     |       |     |     |
|------------------------------|----------|-----|--|----------|-----|-------|-----|-----|
| DB2-750 Pole bracket, double | 300-0168 | 720 |  | 76 x 130 | 950 | 10.20 | 720 | 950 |
|------------------------------|----------|-----|--|----------|-----|-------|-----|-----|

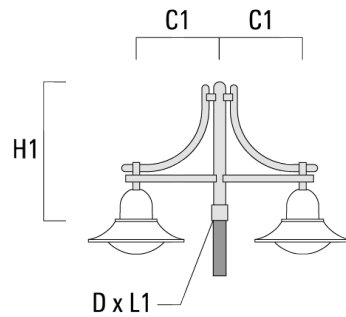

## Pole mounted

| Description                  | Part ID  | C1  | C2 | D × L1   | H1  | Weight (kg) | C   | H   |
|------------------------------|----------|-----|----|----------|-----|-------------|-----|-----|
| DB3-750 Pole bracket, triple | 300-0170 | 720 |    | 76 x 130 | 950 | 13.30       | 720 | 950 |

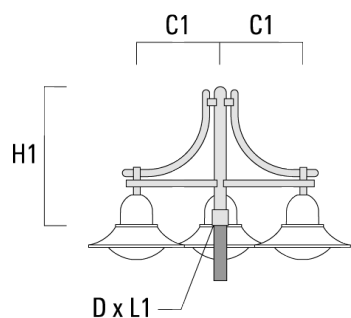

## Wall and pole brackets DS

| Description                  | Part ID  | C1  | C2 | D × L1 | H1  | Weight (kg) | C   | H   |
|------------------------------|----------|-----|----|--------|-----|-------------|-----|-----|
| DS0-750 Wall bracket, single | 300-0070 | 750 | 70 |        | 700 | 2.60        | 750 | 700 |

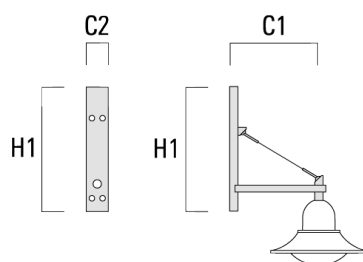

# BSP544 LED

## Pole mounted

| Description                  | Part ID  | C1  | C2 | D x L1   | H1  | Weight (kg) | C   | H   |
|------------------------------|----------|-----|----|----------|-----|-------------|-----|-----|
| DS1-750 Pole bracket, single | 300-0477 | 750 |    | 76 x 130 | 850 | 5.50        | 750 | 850 |

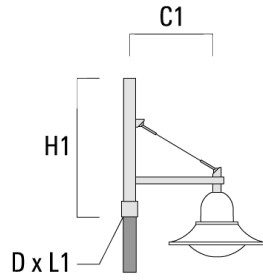

|                              |          |     |  |          |     |      |     |     |
|------------------------------|----------|-----|--|----------|-----|------|-----|-----|
| DS2-750 Pole bracket, double | 300-0765 | 750 |  | 76 x 130 | 850 | 7.20 | 750 | 850 |
|------------------------------|----------|-----|--|----------|-----|------|-----|-----|

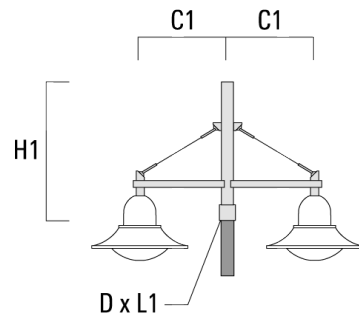

# BSP544 LED

## Pole mounted

| Description                  | Part ID  | C1  | C2 | D x L1   | H1  | Weight (kg) | C   | H   |
|------------------------------|----------|-----|----|----------|-----|-------------|-----|-----|
| DS3-750 Pole bracket, triple | 300-0766 | 750 |    | 76 x 130 | 850 | 8.90        | 750 | 850 |

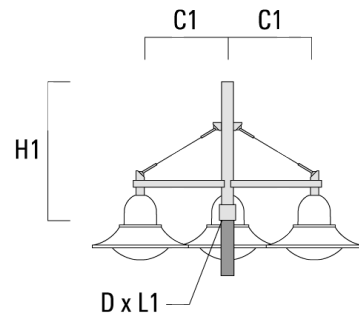

# BSP544 LED

Pole mounted



## Optical Accessories

### Light shield

| Description | Part ID  | Additional information   |
|-------------|----------|--|
| LS180       | 003-4019 | Glare Shield for backlight spill. Glare Shield factory-installed or available as retrofit kit. Suitable for [S60], [S65], [S70], [R65], [P65] lenses. Must be specified at time of ordering. |

#### WE-EF LIGHTING Pty Ltd

6/13 Downard Street, 3195 Braeside, Victoria - Phone: +61 3 8587 0444 - Fax: +61 3 8587 0499

info.australia@we-ef.com - <https://we-ef.com/aus>

Subject to technical changes and errors. - Generated on 23/11/2024