

ZFT440-FT LED

Pole mounted

we-ef



WE-EF LIGHTING Pty Ltd

6/13 Downard Street, 3195 Braeside, Victoria - Phone: +61 3 8587 0444 - Fax: +61 3 8587 0499

info.australia@we-ef.com - <https://we-ef.com/aus>

Subject to technical changes and errors. - Generated on 23/10/2024

ZFT440-FT LED

Pole mounted

we-ef

Description

IP66, Class I. IK09. Marine-grade, die-cast aluminium alloy. 5CE superior corrosion protection + primer including PCS hardware. Silicone CCG® Controlled Compression Gasket. PMMA main lens. The luminaire is factory sealed and does not need to be opened during installation. Integral EC converter. Factory installed LED circuit board. Removable LED boards for upgrading. CAD-optimised indirect optics for superior illumination and glare control.

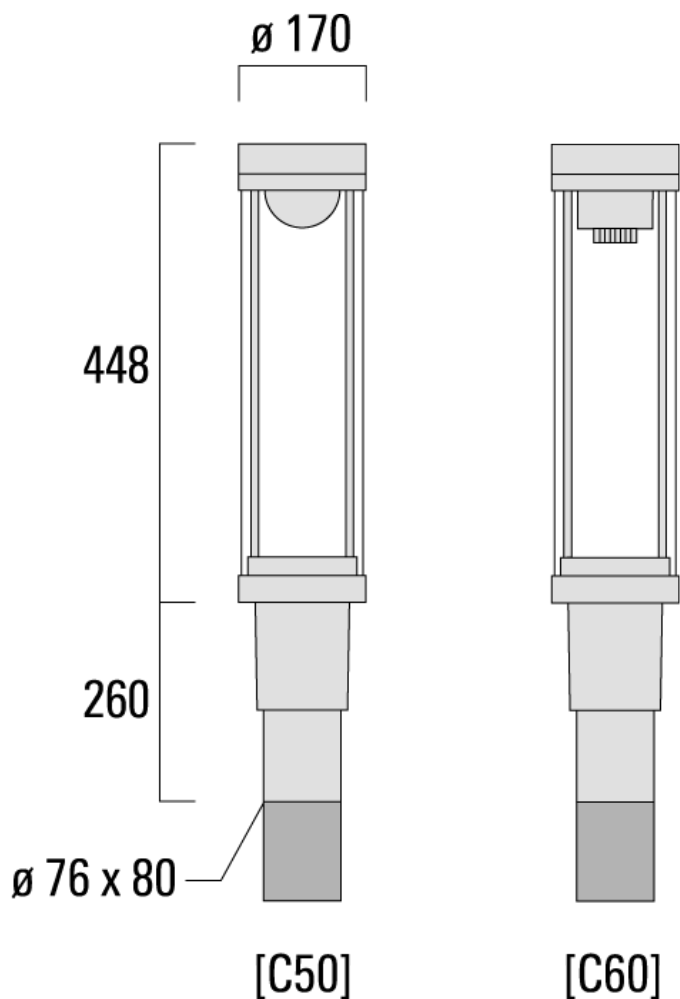



WE-EF LIGHTING Pty Ltd

6/13 Downard Street, 3195 Braeside, Victoria - Phone: +61 3 8587 0444 - Fax: +61 3 8587 0499

info.australia@we-ef.com - <https://we-ef.com/aus>

Subject to technical changes and errors. - Generated on 23/10/2024

Pole mounted**Specifications****Material description**

Body	Marine-grade, die-cast aluminium alloy
Lens	PMMA
Colours	 RAL9004 Signal black  RAL9006 White aluminium  RAL9007 Grey aluminium
Gasket	Silicone CCG® Controlled Compression Gasket
Fasteners	PCS Polymer Coated Stainless Steel Hardware (unpainted)
Ingress protection	IP66
Impact resistance	IK09
Corrosion resistance	5CE+Primer
Windage	0.133 m ²

Electrical description

Power supply	230V / 50 Hz
Driver / Ballast	Integral EC electronic converter in thermally-separated compartment
Power factor	> 0.9
Surge protection	In-pole surge protection SP10 device supplied. Please refer to WE-EF installation instructions for details. Use suffix +A for Integral surge protection.

Additional information

Lifetime	Ta=40° L70B50 > 50000h
Warranty	The product is supplied with 10-year warranty. Please refer to the LED Warranty Statement located on www.we-ef.com for further details.



ZFT440-FT LED

Pole mounted

we-ef

Options

Light distribution

	symmetric distribution [C60]
	controlled symmetric distribution [C50]
	rectangular [R50]



Colour temperature

	3000 K
	4000 K
	2700 K

Nominal Watt

27 W
42 W
2 W
24 W

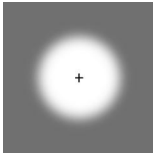
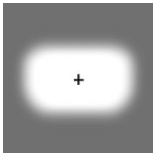
Configurations

Light distribution	Part ID	Light source	Rated lumens	Rated input power	CRI	Weight (kg)
controlled symmetric distribution [C50] 	115-1539	LED-FT-12W / 350 mA - 3000 K	1756.3	14 W	80	5.50
	115-1540	LED-FT-12W / 350 mA - 4000 K	1850.6	14 W	80	5.50
	115-1541	LED-FT-24W / 700 mA - 3000 K	3615.5	27 W	80	5.50
	115-1542	LED-FT-24W / 700 mA - 4000 K	3769.7	27 W	80	5.50
	115-1543	LED-FT-37W / 700 mA - 3000 K	5423.2	42 W	80	5.50
	115-1544	LED-FT-37W / 700 mA - 4000 K	5735.9	42 W	80	5.50
	115-1587	LED-FT-12W / 350 mA - 2700 K	1645	14 W	80	5.50
	115-1588	LED-FT-24W / 700 mA - 2700 K	3469.8	27 W	80	5.50
	115-1589	LED-FT-37W / 700 mA - 2700 K	5264.7	42 W	80	5.50
rectangular [R50] 	115-1842	LED-FT-12W / 350 mA - 3000 K	1549.3	14 W	80	5.50
	115-1861	LED-FT-12W / 350 mA - 4000 K	1632.4	14 W	80	5.50
	115-1862	LED-FT-12W / 350 mA - 2700 K	1451.1	14 W	80	5.50
	115-1863	LED-FT-24W / 700 mA - 3000 K	3189.3	27 W	80	5.50
	115-1864	LED-FT-24W / 700 mA - 4000 K	3325.3	27 W	80	5.50
	115-1865	LED-FT-24W / 700 mA - 2700 K	3060.8	27 W	80	5.50
	115-1866	LED-FT-37W / 700 mA - 3000 K	4784	42 W	80	5.50
	115-1867	LED-FT-37W / 700 mA - 4000 K	5059.8	42 W	80	5.50
	115-1868	LED-FT-37W / 700 mA - 2700 K	4644.1	42 W	80	5.50
	115-2077	LED-FT-17W / 500 mA - 3000 K	2320.2	20 W	80	5.50
	115-2078	LED-FT-17W / 500 mA - 4000 K	2418.4	20 W	80	5.50
115-2079	LED-FT-17W / 500 mA - 2700 K	2218.2	20 W	80	5.50	
symmetric distribution [C60] 	115-1243	LED-FT-24W / 700 mA - 3000 K	2681.2	27 W	80	5.50
	115-1244	LED-FT-24W / 700 mA - 4000 K	2795.5	27 W	80	5.50
	115-1245	LED-FT-37W / 700 mA - 3000 K	4021.8	42 W	80	5.50
	115-1246	LED-FT-37W / 700 mA - 4000 K	4253.7	42 W	80	5.50
	115-1341	LED-FT-12W / 350 mA - 3000 K	1302.5	14 W	80	5.50
	115-1342	LED-FT-12W / 350 mA - 4000 K	1372.4	14 W	80	5.50
	115-1529	LED-FT-24W / 700 mA - 2700 K	2573.2	27 W	80	5.50
	115-1590	LED-FT-12W / 350 mA - 2700 K	1219.9	14 W	80	5.50
	115-1619	LED-FT-37W / 700 mA - 2700 K	3904.2	42 W	80	5.50

ZFT440-FT LED

Pole mounted

we-ef

Control

Eco Step Dim® Basic

Description	Part ID
Eco Step Dim® Basic LED	430-0001

Eco Step Dim® Advanced

Description	Part ID
Eco Step Dim® Advanced LED	430-0002

WE-EF LIGHTING Pty Ltd

6/13 Downard Street, 3195 Braeside, Victoria - Phone: +61 3 8587 0444 - Fax: +61 3 8587 0499

info.australia@we-ef.com - <https://we-ef.com/aus>

Subject to technical changes and errors. - Generated on 23/10/2024

Pole mounted

Mounting Accessories

Wall and pole brackets RZ

Description	Part ID	C1	D1	D2	D × L1	M1	Weight (kg)
RZ0-400 Wall bracket, single	115-1324	277	231	195	76 x 80	12	3.50

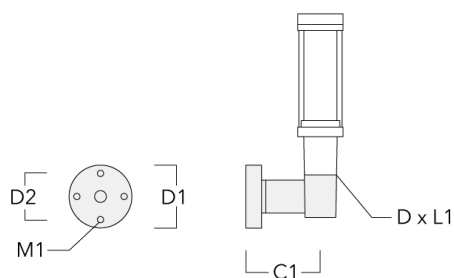

RZ2-400 Pole bracket, double	115-1323	258			76 x 100		4.90
------------------------------	----------	-----	--	--	----------	--	------

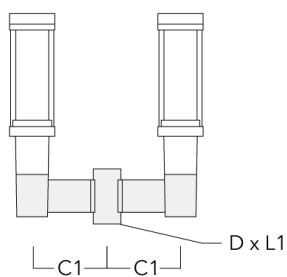

Pole mounted

Optical Accessories

Light shield

Description	Part ID	H1
LS180-[C60]	159-0321	120

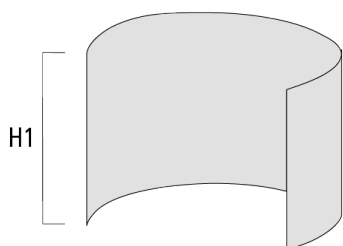

ZFT440-FT LED

Pole mounted

WE-EF LIGHTING Pty Ltd

6/13 Downard Street, 3195 Braeside, Victoria

Phone: +61 3 8587 0444

Fax: +61 3 8587 0499

info.australia@we-ef.com

<https://we-ef.com/aus>

Subject to technical changes and errors.

Generated on 23/10/2024