

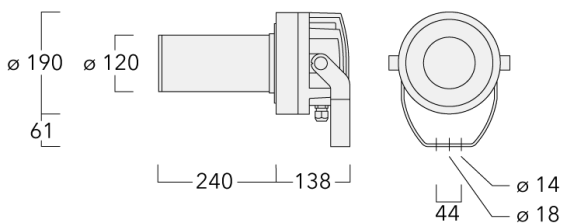





Description

Profile Projector [ZP] for zoom spot. Spherical/double flat convex lens system.

IP66, Class I. IK07. Marine-grade, die-cast aluminium alloy. 5CE superior corrosion protection + primer including PCS hardware. Silicone CCG® Controlled Compression Gasket. Safety glass lens. Two cable glands for improved wiring flexibility. PMMA LED lens array. Factory installed LED circuit board. LED board can be removed for upgrading. Integral EC electronic converter, thermally separated.



Projectors**Specifications****Material description**

Body	Marine-grade, die-cast aluminium alloy
Lens	Safety glass lens
Colours	 RAL9004 Signal black  RAL9006 White aluminium  RAL9007 Grey aluminium
Gasket	Silicone CCG® Controlled Compression Gasket
Fasteners	PCS Polymer Coated Stainless Steel Hardware (unpainted)
Ingress protection	IP66
Impact resistance	IK07
Corrosion resistance	5CE+Primer
Windage	0.06 m ²

Electrical description

Power supply	230V / 50 Hz
Driver / Ballast	Integral EC electronic converter in thermally-separated compartment
Power factor	> 0.9

Additional information

Lifetime	Ta=40° L70B50 > 50000h
Warranty	The product is supplied with 10-year warranty. Please refer to the LED Warranty Statement located on www.we-ef.com for further details.

FLC220 LED [ZP]

Projectors

we-ef

Options

Light distribution



symmetric Zoom-Projector [ZP] - min aperture angle



symmetric Zoom-Projector [ZP] - max aperture angle

Colour temperature



3000 K



4000 K





2700 K

Nominal Watt

0 W

Configurations

Light distribution	Part ID	Light source	Rated lumens	Rated input power	CRI	Weight (kg)
symmetric Zoom-Projector [ZP] - max aperture angle 	139-2117_max	LED-FT-37W / 1050 mA - 3000 K	2490.6	42 W	80	8.20
	139-2123_max	LED-FT-37W / 1050 mA - 4000 K	2596.6	42 W	80	8.20
	139-2126_max	LED-FT-24W / 700 mA - 3000 K	1836.1	27 W	80	8.20
	139-2127_max	LED-FT-24W / 700 mA - 4000 K	1915.6	27 W	80	8.20
	139-2508_max	LED-FT-24W / 700 mA - 2700 K	1783.1	27 W	80	8.20
	139-2511_max	LED-FT-37W / 1050 mA - 2700 K	2419	42 W	80	8.20
symmetric Zoom-Projector [ZP] - min aperture angle 	139-2117_min	LED-FT-37W / 1050 mA - 3000 K	2153.6	42 W	80	8.20
	139-2123_min	LED-FT-37W / 1050 mA - 4000 K	2245.2	42 W	80	8.20
	139-2126_min	LED-FT-24W / 700 mA - 3000 K	1587.7	27 W	80	8.20
	139-2127_min	LED-FT-24W / 700 mA - 4000 K	1656.4	27 W	80	8.20
	139-2508_min	LED-FT-24W / 700 mA - 2700 K	1541.9	27 W	80	8.20
	139-2511_min	LED-FT-37W / 1050 mA - 2700 K	2091.7	42 W	80	8.20

Mounting Accessories

Short post EM

Description	Part ID	D1	D2	H1	M1	Weight (kg)
EM1-M16	270-9038	160	130	200	9	2

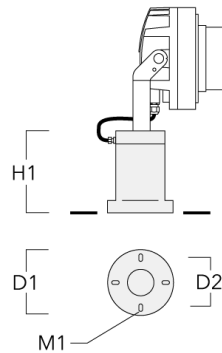

Floodlight mounting bracket TA

Description	Part ID	A	C1	D x L1	Weight (kg)	D x S
TA1 Mounting bracket, single (Ø 108 x 200)	147-0096		130	108 x 200	7.50	108 x 200

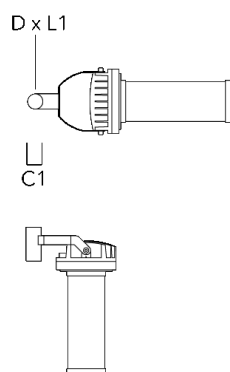

Projectors

Description	Part ID	A	C1	D x L1	Weight (kg)	D x S
TA2 Mounting bracket, double (Ø 108 x 200)	147-0097		130	108 x 200	7.50	108 x 200

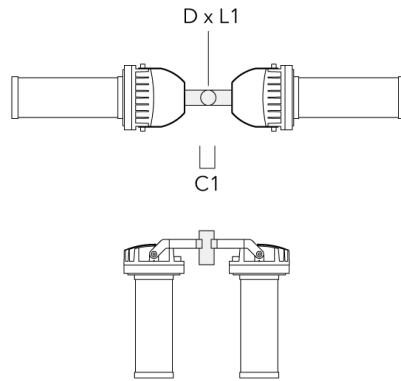

TA2-L Mounting bracket, double (Ø 76 x 200)	147-0105	±90°	420	76 x 200	16.10	76 x 200
---	----------	------	-----	----------	-------	----------

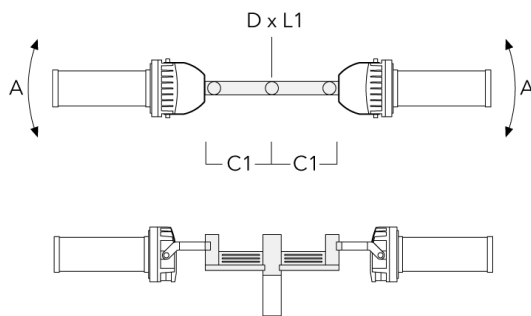

Projectors

Description	Part ID	A	C1	D x L1	Weight (kg)	D x S
TA3 Mounting bracket, triple (Ø 89 x 200)	147-0025	±90°	650	89 x 200	17.90	89 x 200

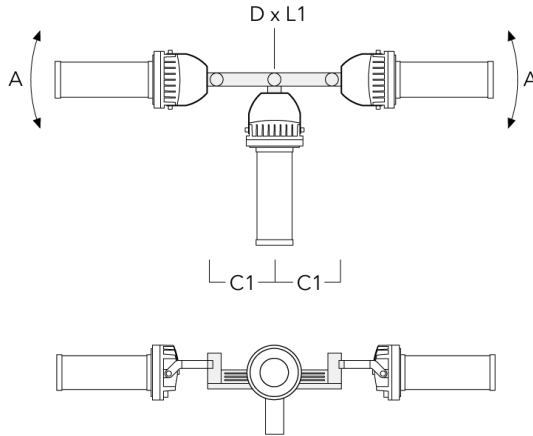

TA3 Mounting bracket, triple (Ø 108 x 200)	147-0098	±90°	650	108 x 200	24.20	108 x 200
--	----------	------	-----	-----------	-------	-----------



Projectors

Description	Part ID	A	C1	D x L1	Weight (kg)	D x S
TA4 Mounting bracket, quad (Ø 89 x 200)	147-0099	±90°	650	89 x 200	20.80	89 x 200



TA4 Mounting bracket, quad (Ø 108 x 200)	147-0100	±90°	650	108 x 200	24.20	108 x 200
--	----------	------	-----	-----------	-------	-----------

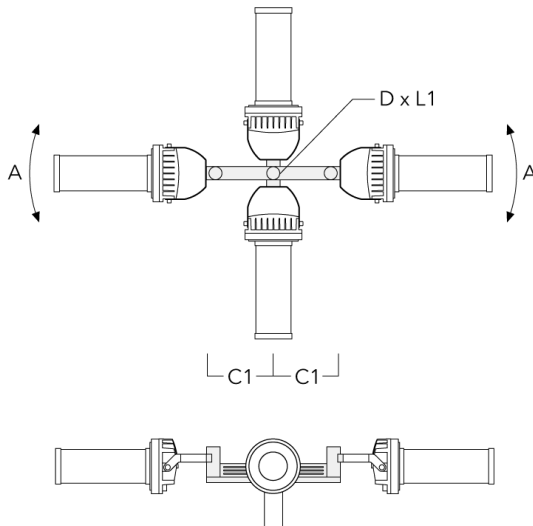

Projectors

Planted root

Description	Part ID	D1	D2	D3	D4	H1	H2	M1	T1	T2	Weight (kg)
Planted root ESV4	300-0461-AP	150	130	60	89	400	350	8	200	50 x 100	3.85

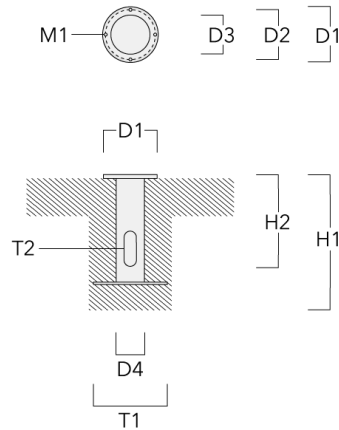

Spigot cap KF

Description	Part ID	D1	Weight (kg)
KF1-M16 Spigot Cap (ø 60 x 100)	310-9120	60 x 100	1.40

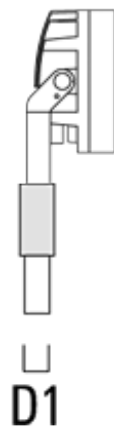

Projectors

Description	Part ID	D1	Weight (kg)
KF1-M16 Spigot Cap (ø 76 x 100)	310-9121	76 x 100	2.2

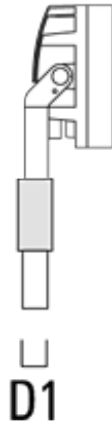

Pole clamp PC - Rotatable

Description	Part ID	D1	Weight (kg)
PC1 76-89/60 Pole clamp, single (Ø 76-89)	139-2702	76-89	1.00

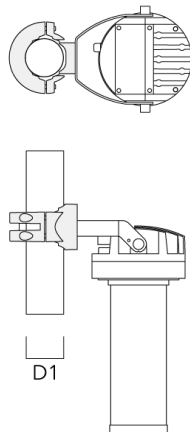

Projectors

Description	Part ID	D1	Weight (kg)
PC2 76-89/60 Pole clamp, double (Ø 76-89)	139-2703	76-89	1.00



PC1 82-109/60 Pole clamp, single (Ø 82-109)	139-2704	82-109	1.10
---	----------	--------	------



Projectors

Description	Part ID	D1	Weight (kg)
PC2 82-109/60 Pole clamp, double (Ø 82-109)	139-2705	82-109	1.10

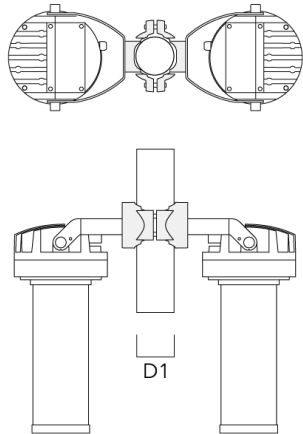

PC1 102-114/60 Pole clamp, single (Ø 102-114)	139-2706	102-114	1.20
--	----------	---------	------



Projectors

Description	Part ID	D1	Weight (kg)
PC2 102-114/60 Pole clamp, double (Ø 102-114)	139-2707	102-114	1.20

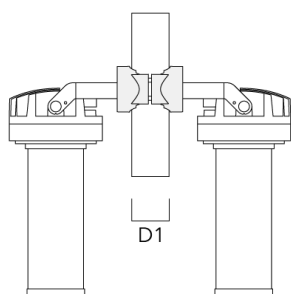
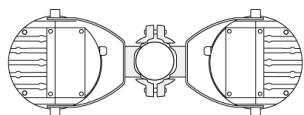

PC1 114-133/60 Pole clamp, single (Ø 114-133)	139-2708	114-133	1.40
--	----------	---------	------

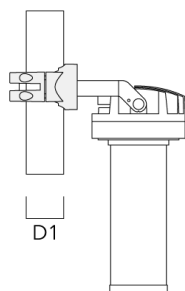
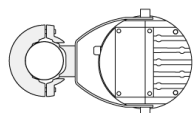

Projectors

Description	Part ID	D1	Weight (kg)
PC2 114-133/60 Pole clamp, double (Ø 114-133)	139-2709	114-133	1.40

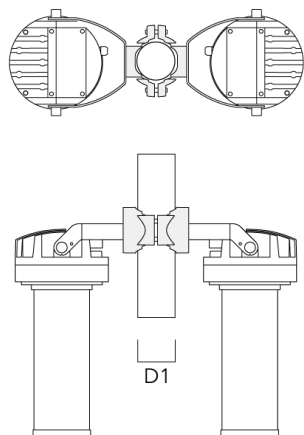

Control

R2C Ready to Connect

Description	Part ID
R2C Ready to Connect (top)	430-0019