





Description

Projecteur LED à découpe (couteaux). Projection de forme quadrilatère précise.

IP66. Classe I. IK07. Corps en fonte d'aluminium. Visserie inox avec traitement PCS.

Protection contre la corrosion 5CE. Joint silicone. Verre de sécurité. Circuit LED installé en usine. (Dé)montage facile sans dérégler le train optique. Une entrée de câble (seconde entrée en option, sur demande). Driver électronique séparé thermiquement, protection surtension 6/6kV intégrée.

Projecteurs**Spécifications****Description du matériel**

Corps	Corps en fonte d'aluminium
Lentille	Verre de sécurité
Couleurs	 RAL9004 Noir de sécurité  RAL9007 Aluminium gris  RAL7016 Gris anthracite  RAL9016 Blanc signalisation
Joint	Joint silicone CCG_R_
Visserie	PCS Inox avec recouvrement polymère
IP	IP66
IK	IK07
Protection contre la corrosion	5CE
Surface exposée au vent	0.06 m ²

Description électrique

Alimentation électrique	220-240V / 50-60 Hz
Driver	Standard - version DALI disponible en option
Power factor	> 0.9

Informations complémentaires

Durée de vie	Ta=25° L70B50 > 50000h
Classe d'efficacité énergétique	F

Projecteurs

Options

Distribution de la lumière



projecteur gobo découpe [FP] -
angle d'ouverture min



projecteur gobo découpe [FP] -
angle d'ouverture max

Température de couleur



3000 K



4000 K





2700 K

Données en sortie de luminaire

0 W

Configurations

Distribution de la lumière	Référence	Source lumineuse	Rated lumens	Rated input power	IRC	Poids (kg)
projecteur gobo découpe [FP] - angle d'ouverture max 	139-2118_max	LED-FT-37W / 1050 mA - 3000 K	2490.6	42 W	80	8.20
	139-2125_max	LED-FT-37W / 1050 mA - 4000 K	2596.6	42 W	80	8.20
	139-2130_max	LED-FT-24W / 700 mA - 3000 K	1836.1	27 W	80	8.20
	139-2131_max	LED-FT-24W / 700 mA - 4000 K	1915.6	27 W	80	8.20
	139-2510_max	LED-FT-24W / 700 mA - 2700 K	1541.9	27 W	80	8.20
	139-2513_max	LED-FT-37W / 1050 mA - 2700 K	2091.7	42 W	80	8.20
projecteur gobo découpe [FP] - angle d'ouverture min 	139-2118_min	LED-FT-37W / 1050 mA - 3000 K	2153.6	42 W	80	8.20
	139-2125_min	LED-FT-37W / 1050 mA - 4000 K	2245.2	42 W	80	8.20
	139-2130_min	LED-FT-24W / 700 mA - 3000 K	1587.7	27 W	80	8.20
	139-2131_min	LED-FT-24W / 700 mA - 4000 K	1656.4	27 W	80	8.20
	139-2510_min	LED-FT-24W / 700 mA - 2700 K	1541.9	27 W	80	8.20
	139-2513_min	LED-FT-37W / 1050 mA - 2700 K	2091.7	42 W	80	8.20

Accessoires d'installation

Socle de montage EM

Description	Référence	D1	D2	H1	M1	Poids (kg)
EM1-M16 socle de montage	270-9038	160	130	200	9	2

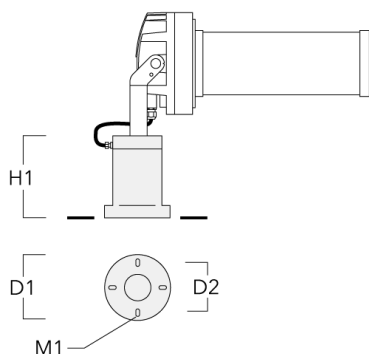

Traverse pour mâts

Description	Référence	A	C1	D x L1	Poids (kg)	D x S
TA1 traverse simple (Ø 108 x 200)	147-0096		130	108 x 200	7.50	108 x 200

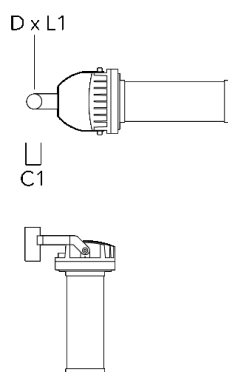

Projecteurs

Description	Référence	A	C1	D x L1	Poids (kg)	D x S
TA2 traverse double (Ø 108 x 200)	147-0097		130	108 x 200	7.50	108 x 200



TA2-L traverse longue orientable (Ø 76 x 200)	147-0105	±90°	420	76 x 200	16.10	76 x 200
---	----------	------	-----	----------	-------	----------

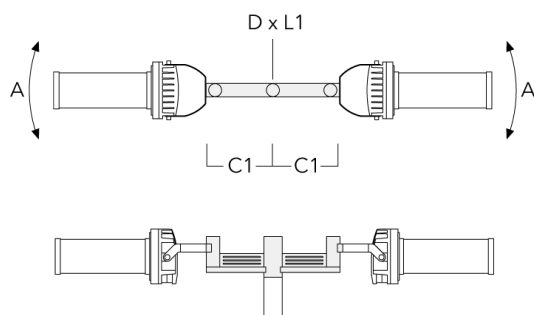

Projecteurs

Description	Référence	A	C1	D x L1	Poids (kg)	D x S
TA3 traverse triple orientable (Ø 89 x 200)	147-0025	±90°	650	89 x 200	17.90	89 x 200

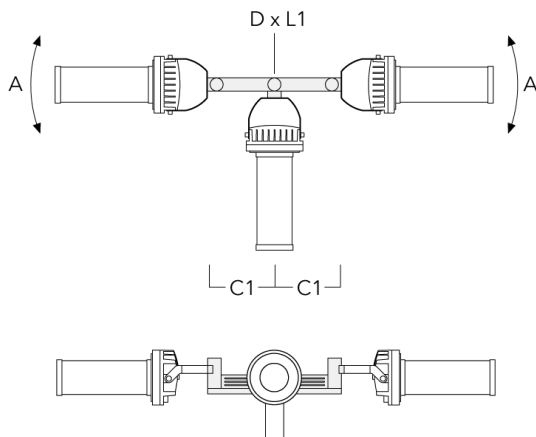

TA3 traverse triple orientable (Ø 108 x 200)	147-0098	±90°	650	108 x 200	24.20	108 x 200
--	----------	------	-----	-----------	-------	-----------



Projecteurs

Description	Référence	A	C1	D x L1	Poids (kg)	D x S
TA4-L Traverse pour 4 projecteurs (Ø 89 x 200)	147-0099	±90°	650	89 x 200	20.80	89 x 200

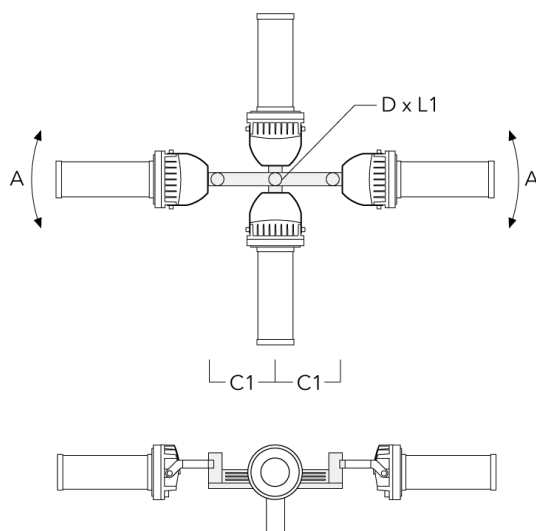

TA4 Traverse pour 4 projecteurs (Ø 108 x 200)	147-0100	±90°	650	108 x 200	24.20	108 x 200
---	----------	------	-----	-----------	-------	-----------



Collier pour mâts TS

WE-EF Switzerland AG

Himmelrichstrasse 6, 6003 Luzern - Téléphone: +41 22 752 49 94

info.switzerland@we-ef.com - https://we-ef.com/ch_fr

Sous réserve de modifications techniques et d'erreurs. - Généré le 23/10/2024

Projecteurs

Description	Référence	D1	Poids (kg)	D
TS1-2/M12 collier simple pour tube (Ø 102-114)	147-0526	102-114	1.50	102-114

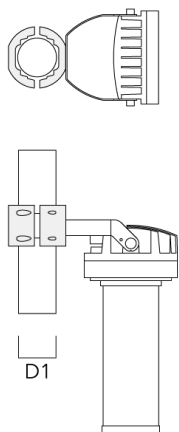

TS1-2/M12 collier simple pour tube (Ø 114-133)	147-0544	114-133	1.70	114-133
---	----------	---------	------	---------

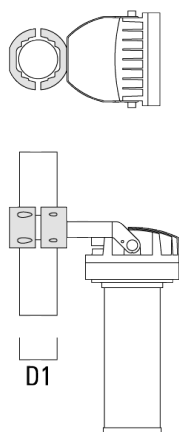

Projecteurs

Description	Référence	D1	Poids (kg)	D
TS2-2/M12 collier double pour tube (Ø 102-114)	147-0527	102-114	1.50	102-114

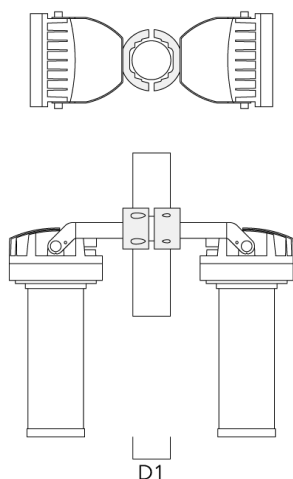

TS2-2/M12 collier double pour tube (Ø 76-89)	147-0545	76-89	1.40	76-89
---	----------	-------	------	-------

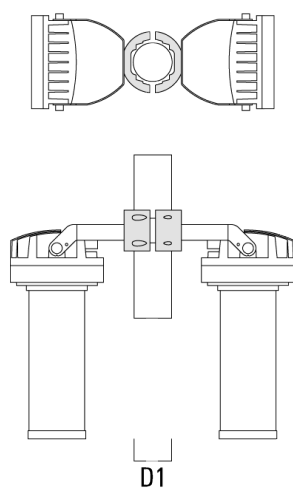

Projecteurs

Description	Référence	D1	Poids (kg)	D
TS2-2/M12 colier double pour tube (Ø 114-133)	147-0546	114-133	1.60	114-133

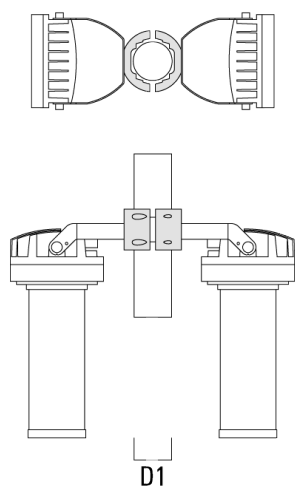

TS1-2/M12 colier simple pour tube (Ø 76-89)	147-0543	76-89	1.40	76-89
--	----------	-------	------	-------

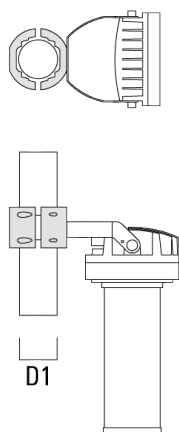

Collier pour mâts PC

WE-EF Switzerland AG

Himmelrichstrasse 6, 6003 Luzern - Téléphone: +41 22 752 49 94

info.switzerland@we-ef.com - https://we-ef.com/ch_fr

Sous réserve de modifications techniques et d'erreurs. - Généré le 23/10/2024

Projecteurs

Description	Référence	D1	Poids (kg)
PC1 76-89/60 collier simple (Ø 76-89)	139-2702	76-89	1.00



PC2 76-89/60 collier double pour tube (Ø 76-89)	139-2703	76-89	1.00
---	----------	-------	------

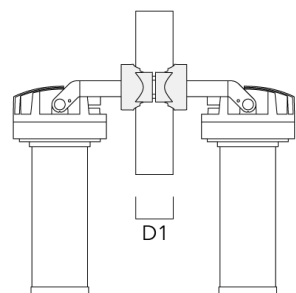

Projecteurs

Description	Référence	D1	Poids (kg)
PC1 82-109/60 collier simple (Ø 82-109)	139-2704	82-109	1.10



PC2 82-109/60 collier double pour tube (Ø 82-109)	139-2705	82-109	1.10
---	----------	--------	------



Projecteurs

Description	Référence	D1	Poids (kg)
PC1 102-114/60 collier simple (Ø 102-114)	139-2706	102-114	1.20



PC2 102-114/60 collier double pour tube (Ø 102-114)	139-2707	102-114	1.20
---	----------	---------	------



Projecteurs

Description	Référence	D1	Poids (kg)
PC1 114-133/60 collier simple (Ø 144-133)	139-2708	114-133	1.40

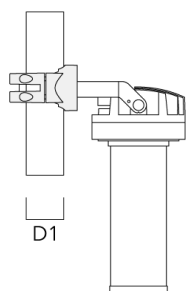
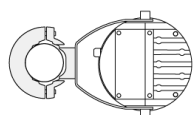

PC2 114-133/60 collier double pour tube (Ø 114-133)	139-2709	114-133	1.40
---	----------	---------	------

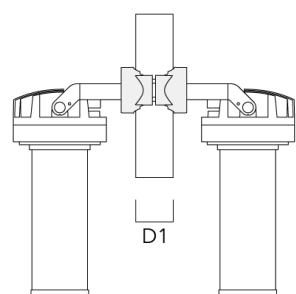
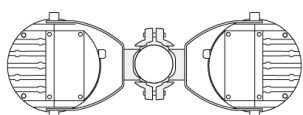

Control

R2C Ready to Connect

Description	Référence
R2C Ready to Connect (top)	430-0019

FLC220 LED [FP]

Projecteurs

WE-EF Switzerland AG

Himmelrichstrasse 6, 6003 Luzern

Téléphone: +41 22 752 49 94

info.switzerland@we-ef.com

https://we-ef.com/ch_fr

Sous réserve de modifications techniques et d'erreurs.

Généré le 23/10/2024