

FLC141 LED



Description

IP66. Classe I. Classe II sur demande. IK07. Corps en fonte d'aluminium. Visserie inox avec traitement PCS. Protection contre la corrosion 5CE. Joint silicone. Verre de sécurité. PMMA-LED. Version en 2200K disponible. À préciser lors de la demande de devis.

Poids	4.70 kg
Distribution de la lumière	faisceau symétrique ovalisante, ultra intensif, 'cut-off'
Source lumineuse	LED-24/48W / 700 mA - 2700 K
IRC	80
Alimentation électrique	ballast électronique
LEDs	24
Rated input power	54 W
Flux lumineux nominal (lm)	
LED Lumen	270
Total Lumen	6480
Tj	85
Rated lumens (lm)	
LED Lumen	236.8
Total Lumen	5683.9
Ta	25

WE-EF Switzerland AG

Himmelrichstrasse 6, 6003 Luzern - Téléphone: +41 22 752 49 94

info.switzerland@we-ef.com - https://we-ef.com/ch_fr

Sous réserve de modifications techniques et d'erreurs. - Généré le 23/11/2024

FLC141 LED

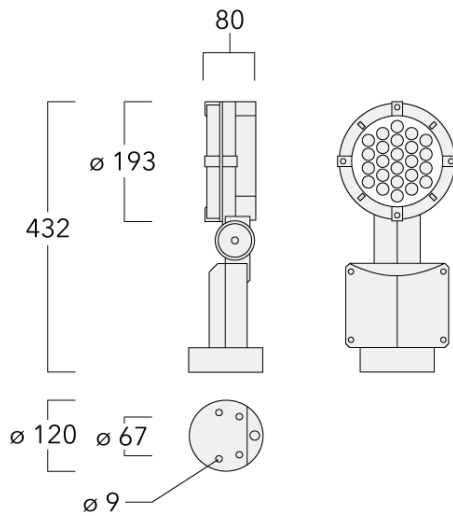

Spécifications

Description du matériel

Corps	Corps en fonte d'aluminium, visserie inox avec traitement PCS
Lentille	Verre de sécurité
Couleurs	<div style="display: flex; align-items: center;"> <div style="width: 20px; height: 15px; background-color: black; margin-right: 5px;"></div> <div>RAL9004 Noir de sécurité</div> </div> <div style="display: flex; align-items: center; margin-top: 5px;"> <div style="width: 20px; height: 15px; background-color: gray; margin-right: 5px;"></div> <div>RAL9007 Aluminium gris</div> </div> <div style="display: flex; align-items: center; margin-top: 5px;"> <div style="width: 20px; height: 15px; background-color: darkgray; margin-right: 5px;"></div> <div>RAL7016 Gris anthracite</div> </div> <div style="display: flex; align-items: center; margin-top: 5px;"> <div style="width: 20px; height: 15px; background-color: lightgray; margin-right: 5px;"></div> <div>RAL9016 Blanc signalisation</div> </div>
Joint	Joint silicone CCG®
Visserie	PCS Inox avec recouvrement polymère
IP	IP66
IK	IK07
Protection contre la corrosion	5CE
Surface exposée au vent	0.057 m ²

WE-EF Switzerland AG

Himmelrichstrasse 6, 6003 Luzern - Téléphone: +41 22 752 49 94

info.switzerland@we-ef.com - https://we-ef.com/ch_fr

Sous réserve de modifications techniques et d'erreurs. - Généré le 23/11/2024

FLC141 LED

Description électrique

Alimentation électrique	220-240V / 50-60 Hz
Driver	Driver électronique séparé thermiquement

Informations complémentaires

Durée de vie	Ta=25° L90B10 > 90000h
Classe d'efficacité énergétique	C-D

Accessoires Optiques

Visière

Description	Référence	A	C1
Visière ES	146-0229	120	145



Canon anti-éblouissement

Description	Référence	A	C1
Canon anti-éblouissement ET	146-0398	120	145



FLC141 LED

Grille nid d'abeille

Description	Référence	C1
IW-FLC141-LED - [EE][EES]	146-0626	145



C1

Accessoires d'installation

Collier pour tubes SP

Description	Référence	D1	Poids (kg)	D
SP1-2/M8 collier simple (Ø 76-89)	146-0246	76-89	1.20	76-89



SP2-2/M8 collier double (Ø 38-60)	146-0247	38-60	1	38-66
-----------------------------------	----------	-------	---	-------



FLC141 LED

Description	Référence	D1	Poids (kg)	D
SP2-2/M8 collier double (Ø 76-89)	146-0248	76-89	1.20	76-89



SP1-2/M8 collier simple pour tube (Ø 38-60)	146-0245	38-60	1	38-60
---	----------	-------	---	-------



FLC141 LED

Socle de montage EM

Description	Référence	D1	D2	H1	M1	Poids (kg)
EM1-2/M5 socle de montage en fonte d'aluminium	146-0253	160	130	200	9	1.10

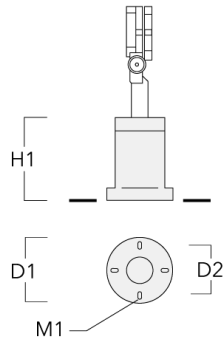

Piquet à planter EF

Description	Référence	H1	Poids (kg)
Piquet à planter EF1-2/M5	146-0251	270	0.40

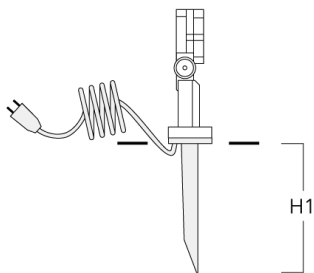

FLC141 LED

Base à enterrer

Description	Référence	D1	D2	D3	D4	H1	H2	M1	Poids (kg)
Base à enterrer ESV4	300-0461	145	130	102	108	400	350	8	7.85

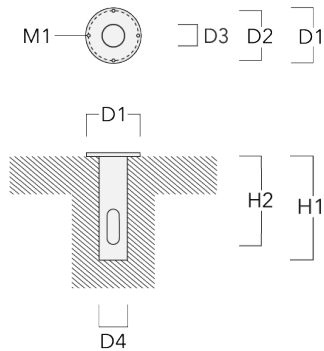

JB1 Boîte de dérivation étanche

Description	Référence	D1	D2	M1	Poids (kg)
JB1 Junction box	310-9000	135	67	9	1.6

