

115-1712

ZAT440 LED

we-ef



Description

IP66, Class I, IK09. Marine-grade, die-cast aluminium alloy. 5CE superior corrosion protection including PCS hardware. Silicone CCG® Controlled Compression Gasket. PMMA main lens. Integral EC electronic converter in thermally separated compartment. CAD-optimised OLC® One LED Concept optics for superior illumination and glare control. Factory installed LED circuit board. The luminaire is factory-sealed and does not need to be opened during installation.

Optional 2200 K version available. To be specified at time of ordering.

| | |
|--------------------|----------------------------|
| Weight | 17.41 lb |
| Light distribution | [R65] Type IV Medium |
| Light source | LED-9/9W / 350 mA - 2700 K |
| CRI | 80 |
| Power supply | electronic gear |
| LEDs | 9 |
| Rated input power | 11 W |

Nominal Lumen (lm)

| | |
|-------------|------|
| LED Lumen | 145 |
| Total Lumen | 1305 |
| Tj | 85 |

Rated lumens (lm)

| | |
|-------------|--------|
| LED Lumen | 113.8 |
| Total Lumen | 1024.5 |
| Ta | 25 |

WE-EF LIGHTING USA, LLC

410-D Keystone Drive, 15086 Warrendale, PA 15086 - Phone: +1 724 742 0030
customersupport.usa@we-ef.com - <https://we-ef.com/us>
Subject to technical changes and errors. - Generated on 11/23/2024

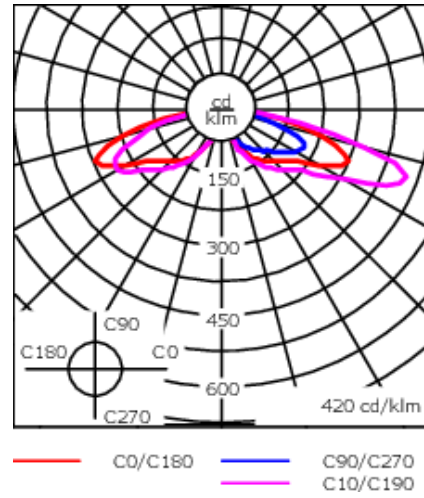
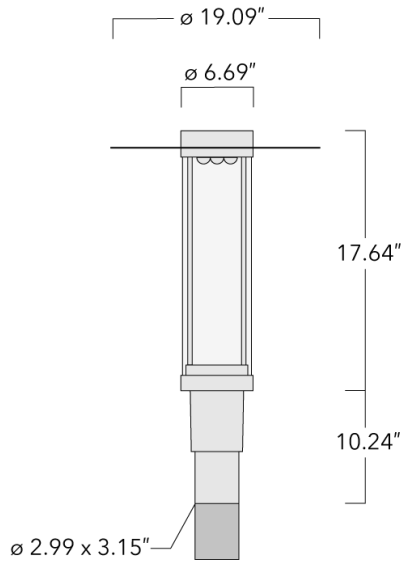

Specifications

Material description

| | |
|----------------------|---|
| Body | Marine-grade, die-cast aluminium alloy |
| Lens | PMMA |
| Colors | <div style="display: flex; flex-direction: column; gap: 5px;"> <div> RAL9004 Black</div> <div> RAL9007 Grey Metallic</div> <div> RAL9016 White</div> <div> RAL8019 Dark Bronze</div> </div> |
| Gasket | Silicone CCG® Controlled Compression Gasket |
| Fasteners | PCS Polymer Coated Stainless Steel Hardware |
| Ingress protection | IP66 |
| Impact resistance | IK09 |
| Corrosion resistance | 5CE |
| Windage | 0.160 m ² |

Electrical description

| | |
|------------------|---------------------------------------|
| Power supply | Integral [ECG] LED driver in 120-277V |
| Driver / Ballast | Integral EC electronic converter |
| Power factor | > 0.9 |

WE-EF LIGHTING USA, LLC

410-D Keystone Drive, 15086 Warrendale, PA 15086 - Phone: +1 724 742 0030
 customersupport.usa@we-ef.com - <https://we-ef.com/us>
 Subject to technical changes and errors. - Generated on 11/23/2024

115-1712

ZAT440 LED

we-ef

Additional information

Lifetime Ta=25°/40° L90B10 > 90000h

Listings Contact WE-EF USA for ETL/UL certification status.

WE-EF LIGHTING USA, LLC

410-D Keystone Drive, 15086 Warrendale, PA 15086 - Phone: +1 724 742 0030
customersupport.usa@we-ef.com - <https://we-ef.com/us>

Subject to technical changes and errors. - Generated on 11/23/2024

Mounting Accessories

Wall and pole brackets RZ

| Description | Part ID | C1 | D1 | D2 | D x L1 | M1 | Weight (lb) |
|------------------------------|----------|--------|------|-------|---------|-------|-------------|
| RZ0-400 Wall bracket, single | 115-1324 | 10.90" | 9.1" | 7.67" | 3" x 3" | 0.47" | 7.72 lbs |

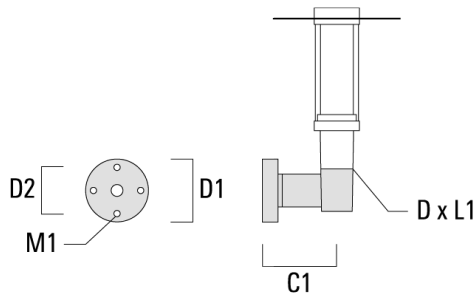

| | | | | | | | |
|------------------------------|----------|--------|--|--|---------|--|-----------|
| RZ2-400 Pole bracket, double | 115-1323 | 10.16" | | | 3" x 3" | | 10.80 lbs |
|------------------------------|----------|--------|--|--|---------|--|-----------|

