



Description

IP66, Class I. IK10. Marine-grade, die-cast aluminium alloy. 5CE superior corrosion protection + primer including PCS hardware. Polycarbonate lens. Silicone rubber gasket.

Integral EC electronic converter. Advanced thermal management protects LEDs while optimising lumens output. Two cable entries.

Pre-installation blackout is recommended for mounting in concrete, available on request. Optional 2200 K version available. To be specified at time of ordering.

Weight	1.10 kg
Light distribution	diffused distribution
Light source	LED-6/6W / 350 mA - 2700 K
CRI	80
Power supply	EC
LEDs	6
Rated input power	7.5 W

Nominal Lumen (lm)

LED Lumen	145
Total Lumen	870
Tj	85

Rated lumens (lm)

LED Lumen	34.2
Total Lumen	205.2
Ta	25

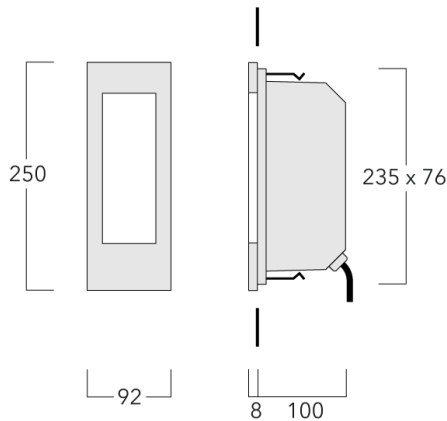

Specifications

Material description

Body	Marine-grade die-cast aluminium alloy
Lens	Polycarbonate lens
Colours	<div style="display: flex; align-items: center;"> <div style="width: 20px; height: 15px; background-color: black; margin-right: 5px;"></div> RAL9004 Signal black </div> <div style="display: flex; align-items: center; margin-top: 5px;"> <div style="width: 20px; height: 15px; background-color: #cccccc; margin-right: 5px;"></div> RAL9006 White aluminium </div> <div style="display: flex; align-items: center; margin-top: 5px;"> <div style="width: 20px; height: 15px; background-color: #808080; margin-right: 5px;"></div> RAL9007 Grey aluminium </div>
Gasket	Silicone rubber gasket
Fasteners	PCS Polymer Coated Stainless Steel Hardware (unpainted)
Ingress protection	IP66
Impact resistance	IK10
Corrosion resistance	5CE+Primer

Electrical description

Power supply	230V / 50 Hz
Driver / Ballast	Integral EC electronic converter

Additional information

Lifetime	Ta=40° L80B10 > 54000h
Warranty	The product is supplied with 10-year warranty. Please refer to the LED Warranty Statement located on www.we-ef.com for further details.

Mounting Accessories

Installation blackout

Description	Part ID	A	B	C1
Installation blackout BST25-II	133-0078	267	132	140

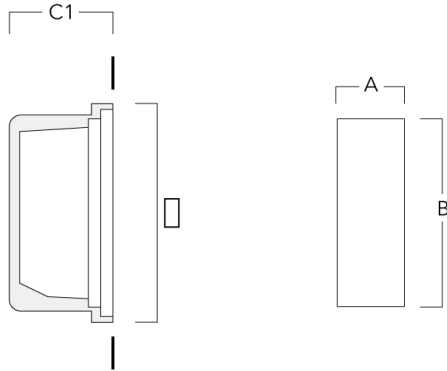

Installation blackout BST25-I	133-0076	267	132	130
-------------------------------	----------	-----	-----	-----

