



### Beschreibung

RGBW/RGBA Farbwechsler Projektor [ZP] zur Erzeugung von scharf abgegrenzten Lichtkreisen. Sphärisches und asphärisches, zweifaches Plankonvexlinsensystem aus Glas zur Erzeugung eines parallelen Lichtbündels. Colour Boost Technologie.

IP66, SKIII. IK05. Korrosionsbeständiger Aluminiumguss. PCS beschichtete Edelstahlschrauben. 5CE Korrosionsschutz. CCG® Silikondichtung. Sicherheitsglas. Eine Kabelverschraubung, eine zweite Kabelverschraubung zur Durchverdrahtung als Variante erhältlich. Betriebsgeräte in externer Gerätebox (mittel), vorverdrahtet. Eingebaute LED Platine. CAD-optimierte Glas LED Linsen. DMX Schnittstelle.

Gewicht	4.00 kg
Lichtverteilung	symmetric Zoom-Projector [ZP] - min aperture angle
Lichtquelle	LED-FT-15W - RGBW/4K
CRI	20/80
Netz	EVG
LEDs	1
Bemessungsleistung	17 W

### Bemessungslichtstrom (lm)

LED Lumen	333.5
Total Lumen	333.5
Ta	25

### Nominal Lichtstrom (lm)

LED Lumen	1400
Total Lumen	1400
Tc	25

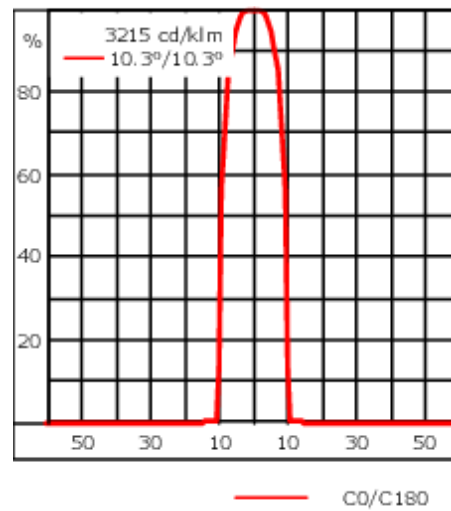

## Spezifikationen

### Materialbeschreibung

Gehäuse	Korrosionsbeständiger Aluminiumguss
Abdeckung	Sicherheitsglas
Farben	<div style="display: flex; align-items: center;"> <div style="width: 20px; height: 15px; background-color: black; margin-right: 5px;"></div> <span>RAL9004 Signalschwarz</span> </div> <div style="display: flex; align-items: center; margin-top: 5px;"> <div style="width: 20px; height: 15px; background-color: gray; margin-right: 5px;"></div> <span>RAL9007 Graualuminium</span> </div> <div style="display: flex; align-items: center; margin-top: 5px;"> <div style="width: 20px; height: 15px; background-color: darkgray; margin-right: 5px;"></div> <span>RAL7016 Anthrazitgrau</span> </div> <div style="display: flex; align-items: center; margin-top: 5px;"> <div style="width: 20px; height: 15px; background-color: lightgray; margin-right: 5px;"></div> <span>RAL9016 Verkehrsweiß</span> </div>
Dichtung	CCG® Silikondichtung
Schrauben	PCS beschichtete Edelstahlschrauben
Schutzart	IP66
Schlagfestigkeit	IK05
Korrosionsbeständigkeit	5CE

### Elektrische Beschreibung

Netzgerät / Vorschaltgerät	DMX (separate gearbox)
Leistungsfaktor	> 0.9

### Weitere Informationen

Lebensdauer	Ta=25° L70B50 > 50000h
Energieeffizienzklasse	G (Lichtquelle)

#### WE-EF Switzerland AG

Himmelrichstrasse 6, 6003 Luzern - Tel: +41 41 210 49 95  
 info.switzerland@we-ef.com - [https://we-ef.com/ch\\_de](https://we-ef.com/ch_de)  
 Technische Änderungen und Irrtümer vorbehalten. - Erstellt am 23.11.2024

## Elektrisches Zubehör

## Gerätebox

Beschreibung	Artikelnummer	A	B	C1	C2	Gewicht (kg)
GB200 R200x120 Gerätebox (mittel)	139-2526	75	120	229	200	1.05

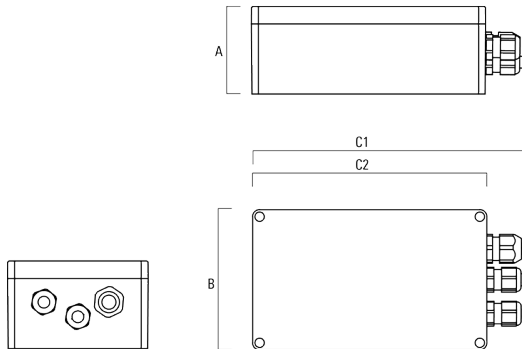

GB200 R230x140 Gerätebox (groß)	139-2527	95	140	259	230	1.20
---------------------------------	----------	----	-----	-----	-----	------

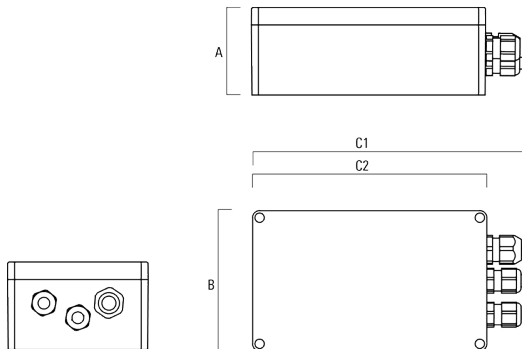

## Montagezubehör

## Mastschelle PC

Beschreibung	Artikelnummer	D1	Gewicht (kg)
PC1 76-89/60 Mastschelle, einfach (Ø 76-89)	139-2702	76-89	1.00

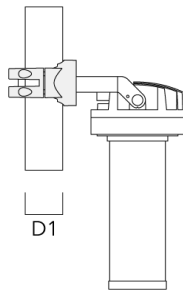

PC2 76-89/60 Mastschelle, zweifach (Ø 76-89)	139-2703	76-89	1.00
--	----------	-------	------

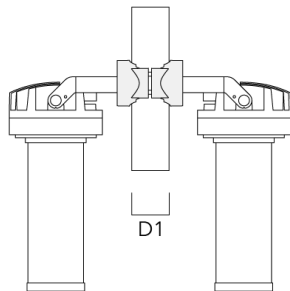
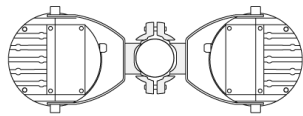

## FLC210-CC LED [ZP]

---

Beschreibung	Artikelnummer	D1	Gewicht (kg)
PC2 82-109/60 Mastschelle, zweifach (Ø 82-109)	139-2705	82-109	1.10

---



---

PC1 102-114/60 Mastschelle, einfach (Ø 102-114)	139-2706	102-114	1.20
--	----------	---------	------

---

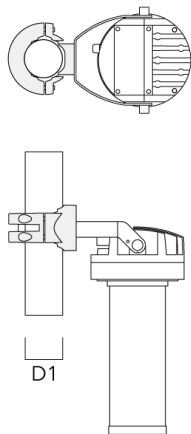

## FLC210-CC LED [ZP]

Beschreibung	Artikelnummer	D1	Gewicht (kg)
PC2 102-114/60 Mastschelle, zweifach (Ø 102-114)	139-2707	102-114	1.20



PC1 114-133/60 Mastschelle, einfach (Ø 144-133)	139-2708	114-133	1.40
--	----------	---------	------

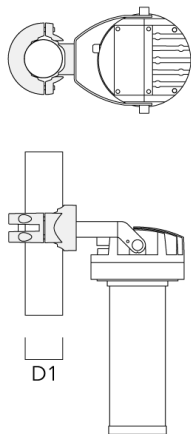

## FLC210-CC LED [ZP]

Beschreibung	Artikelnummer	D1	Gewicht (kg)
PC2 114-133/60 Mastschelle, zweifach (Ø 114-133)	139-2709	114-133	1.40

