

145-7619

we-ef

FLC311 Spigot mounted



Description

IP66. IK08. Marine-grade, die-cast aluminium alloy. 5CE superior corrosion protection including PCS hardware. Safety glass lens. Silicone CCG® Controlled Compression Gasket. Luminaire is factory-sealed and does not need to be opened during installation.

Integral EC electronic converter. Advanced thermal management protects LEDs while optimising lumens output. CAD-optimised optics for superior illumination and glare control. Including 5 ft of flexible PVC free cable.

Optical accessories are factory-installed. To be specified at time of ordering.

6-12W / 120V / 0-10V Dimming.
6W / 24V DC / 0-10V Dimming. (available upon request)

Contact the factory for 277V/347V options.

Weight	1.60 lb
Light distribution	symmetric, very narrow beam [VN]
Light source	LED-3/9W / 250 mA - 2700 K
CRI	80
Power supply	electronic gear
LEDs	3
Rated input power	11 W
Nominal Lumen (lm)	
LED Lumen	365
Total Lumen	1095
Tj	85
Rated lumens (lm)	
LED Lumen	283.2
Total Lumen	849.6
Ta	25

WE-EF LIGHTING USA, LLC

410-D Keystone Drive, 15086 Warrendale, PA 15086 - Phone: +1 724 742 0030
customersupport.usa@we-ef.com - <https://we-ef.com/us>
Subject to technical changes and errors. - Generated on 11/23/2024

145-7619

we-ef

FLC311 Spigot mounted

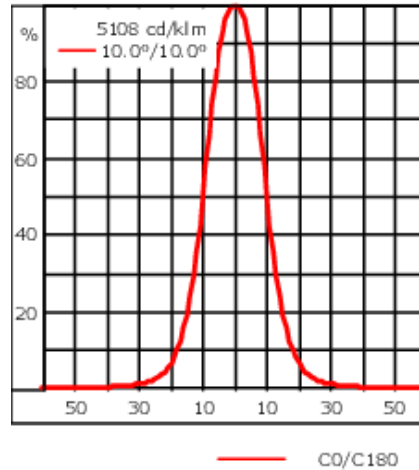
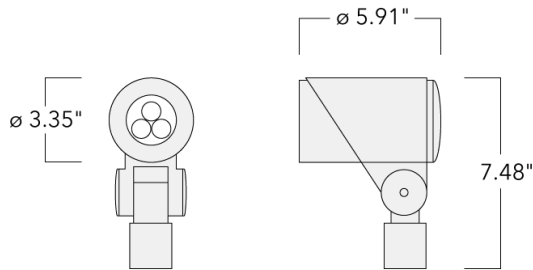

Specifications

Material description

Body	Marine-grade, die-cast aluminium alloy
Lens	Safety glass lens
Colors	<div style="display: flex; flex-direction: column; gap: 5px;"> <div> RAL9004 Black</div> <div> RAL9007 Grey Metallic</div> <div> RAL9016 White</div> <div> RAL8019 Dark Bronze</div> </div>
Gasket	Silicone CCG® Controlled Compression Gasket
Fasteners	PCS hardware
Ingress protection	IP66
Impact resistance	IK08
Corrosion resistance	5CE
Windage	0.215 ft ²

Electrical description

Power supply	120-277VAC/50-60 Hz (24V DC available upon request)
Driver / Ballast	Integral [ECG] electronic driver 120V-277V. (24VDC low voltage, available upon request)
Power factor	>0.9

WE-EF LIGHTING USA, LLC

410-D Keystone Drive, 15086 Warrendale, PA 15086 - Phone: +1 724 742 0030

customersupport.usa@we-ef.com - <https://we-ef.com/us>

Subject to technical changes and errors. - Generated on 11/23/2024

145-7619

we-ef

FLC311 Spigot mounted

Additional information

Lifetime	Ta=25°/40° L90B10 > 90000h
Dimming	0-10V as standard
Listings	ETL, UL-1598, CSA-C22.2#250.0. Suitable for Wet Locations.

WE-EF LIGHTING USA, LLC

410-D Keystone Drive, 15086 Warrendale, PA 15086 - Phone: +1 724 742 0030
customersupport.usa@we-ef.com - <https://we-ef.com/us>
Subject to technical changes and errors. - Generated on 11/23/2024

FLC311 Spigot mounted

Mounting Accessories

Threaded Nipple

Description	Part ID	Weight (lb)
3/4 inch Threaded Nipple	145-6903	0.24
1/2 inch Threaded Nipple	145-6902	0.2

Flat surface and Column fitter

Description	Part ID	A	B	D1	D2	M1	Weight (lb)
Column fitter FLC300	145-9536	70		≥ 3.0	2.75	0.23	.44 lbs



FLC311 Spigot mounted

Description	Part ID	A	B	D1	D2	M1	Weight (lb)
Flat surface fitter FLC300	145-9535	100	85				0.20

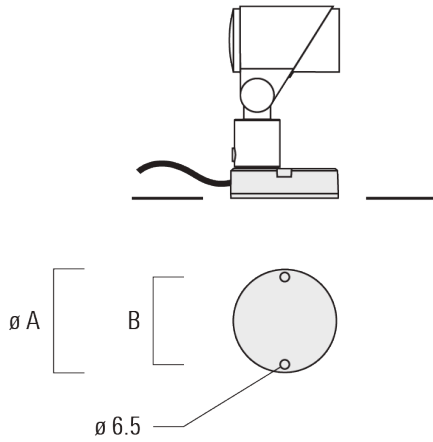

Ground spike EF

Description	Part ID	A	Weight (lb)
Ground spike EF1 for FLC300	310-9102	10.63	1.20

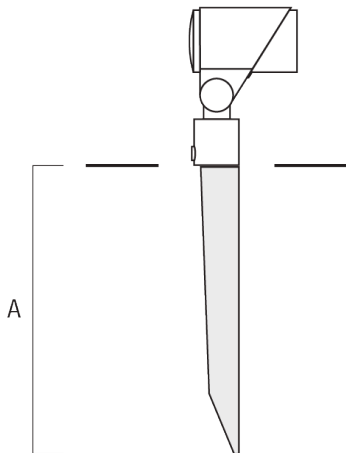

WE-EF LIGHTING USA, LLC

410-D Keystone Drive, 15086 Warrendale, PA 15086 - Phone: +1 724 742 0030
 customersupport.usa@we-ef.com - <https://we-ef.com/us>
 Subject to technical changes and errors. - Generated on 11/23/2024

FLC311 Spigot mounted

Junction box JB1

Description	Part ID	A	B	C1	D1	Weight (lb)
Junction box JB1 with side entry	310-9002	4.21	2.64	5.31	2.64	1.20

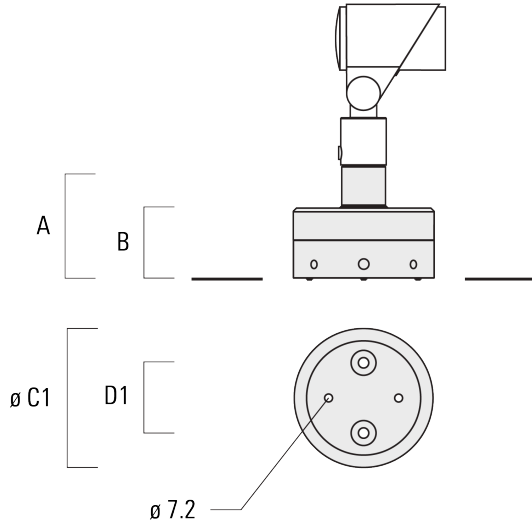

Junction box JB1 with wall entry	310-9025	4.21	2.64	5.31	2.64	1.10
----------------------------------	----------	------	------	------	------	------

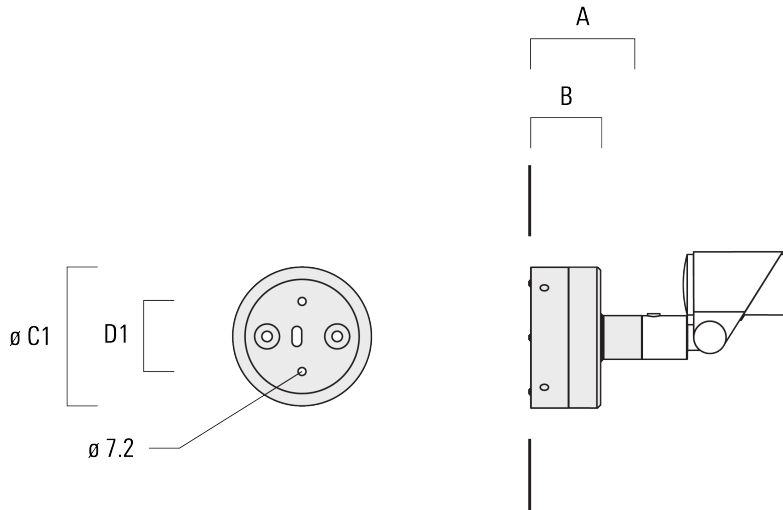

WE-EF LIGHTING USA, LLC

410-D Keystone Drive, 15086 Warrendale, PA 15086 - Phone: +1 724 742 0030

customersupport.usa@we-ef.com - <https://we-ef.com/us>

Subject to technical changes and errors. - Generated on 11/23/2024

FLC311 Spigot mounted

Description	Part ID	A	B	C1	D1	Weight (lb)
Junction box JB1 with side entry (conduit)	310-9022	4.21	2.64	5.31	2.64	1.20

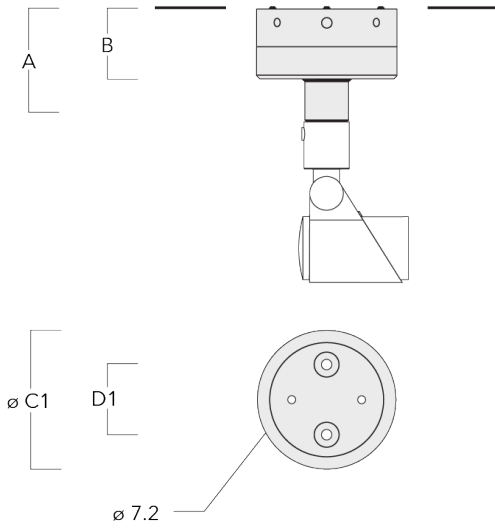

WE-EF LIGHTING USA, LLC

410-D Keystone Drive, 15086 Warrendale, PA 15086 - Phone: +1 724 742 0030
 customersupport.usa@we-ef.com - <https://we-ef.com/us>

Subject to technical changes and errors. - Generated on 11/23/2024

145-7619

FLC311 Spigot mounted

Optical Accessories

Softening Lens

Description	Part ID	C1
Flood lens IO-360 for [EE]	145-7786	59

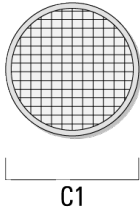

Flood lens IO-360 for [EES]	145-7780	59
-----------------------------	----------	----

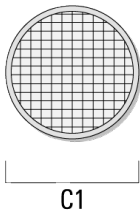

WE-EF LIGHTING USA, LLC

410-D Keystone Drive, 15086 Warrendale, PA 15086 - Phone: +1 724 742 0030
customersupport.usa@we-ef.com - <https://we-ef.com/us>
Subject to technical changes and errors. - Generated on 11/23/2024

145-7619

we-ef

FLC311 Spigot mounted

Linear spread lens

Description	Part ID	C1
Linear spread lens IO-180	145-7781	59

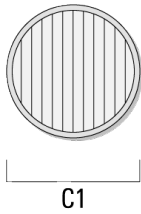

Wallwash lens

Description	Part ID	C1
Wallwash lens IO-20	145-7782	59

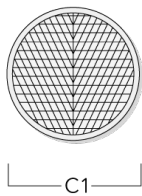

WE-EF LIGHTING USA, LLC

410-D Keystone Drive, 15086 Warrendale, PA 15086 - Phone: +1 724 742 0030
customersupport.usa@we-ef.com - <https://we-ef.com/us>
Subject to technical changes and errors. - Generated on 11/23/2024

145-7619

we-ef

FLC311 Spigot mounted

Honeycomb louvre

Description	Part ID	C1
Honeycomb louvre IW	145-7783	59

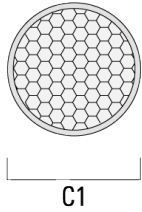

Glare shield

Description	Part ID	A	C1
Glare shield ES	145-7784	34	85

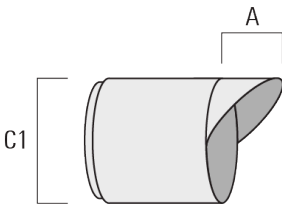

WE-EF LIGHTING USA, LLC

410-D Keystone Drive, 15086 Warrendale, PA 15086 - Phone: +1 724 742 0030
customersupport.usa@we-ef.com - <https://we-ef.com/us>
Subject to technical changes and errors. - Generated on 11/23/2024

145-7619

we-ef

FLC311 Spigot mounted

Snoot

Description	Part ID	A	C1
Snoot ET	145-7785	34	85

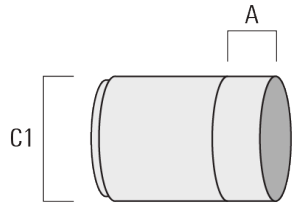

WE-EF LIGHTING USA, LLC

410-D Keystone Drive, 15086 Warrendale, PA 15086 - Phone: +1 724 742 0030
customersupport.usa@we-ef.com - <https://we-ef.com/us>
Subject to technical changes and errors. - Generated on 11/23/2024

145-7619

we-ef

FLC311 Spigot mounted

Control

0-10 V, 24VDC low voltage version

Description	Part ID
24VDC low voltage version, 0-10 V	0033

WE-EF LIGHTING USA, LLC

410-D Keystone Drive, 15086 Warrendale, PA 15086 - Phone: +1 724 742 0030
customersupport.usa@we-ef.com - <https://we-ef.com/us>

Subject to technical changes and errors. - Generated on 11/23/2024