

127-1217

ALP534-FT LED

we-ef



Description

IP55, Class I. IK10. Marine-grade die-cast aluminium alloy. 5CE superior corrosion protection + primer including PCS hardware. Silicone rubber gasket. Polycarbonate main lens. CAD-optimised indirect optics for superior illumination and glare control. DALI.

Brackets to be ordered separately.

| | |
|---------------------------|------------------------------|
| Weight | 6.10 kg |
| Light distribution | symmetric distribution [C60] |
| Light source | LED-FT-17W / 500 mA - 3000 K |
| CRI | 80 |
| Power supply | EC |
| LEDs | 1 |
| Rated input power | 20 W |
| Rated lumens (lm) | |
| LED Lumen | 2099.1 |
| Total Lumen | 2099.1 |
| Ta | 25 |
| Nominal Lumen (lm) | |
| LED Lumen | 3070 |
| Total Lumen | 3070 |
| Tc | 25 |

WE-EF LIGHTING Pty Ltd

6/13 Downard Street, 3195 Braeside, Victoria - Phone: +61 3 8587 0444 - Fax: +61 3 8587 0499

info.australia@we-ef.com - <https://we-ef.com/aus>

Subject to technical changes and errors. - Generated on 23/11/2024

127-1217

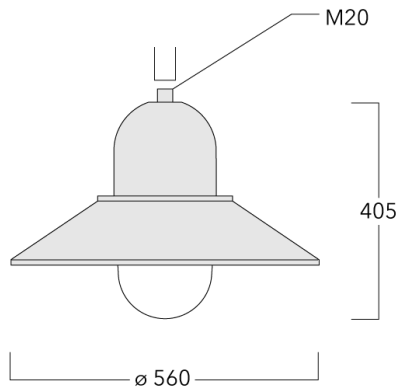

ALP534-FT LED

we-ef



Specifications

Material description

| | |
|----------------------|---|
| Body | Marine-grade, die-cast aluminium alloy |
| Lens | Polycarbonate lens |
| Colours |  RAL9004 Signal black  RAL9006 White aluminium  RAL9007 Grey aluminium |
| Gasket | Silicone rubber gasket |
| Fasteners | PCS Polymer Coated Stainless Steel Hardware |
| Ingress protection | IP55 |
| Impact resistance | IK10 |
| Corrosion resistance | 5CE+Primer |
| Windage | 0.12 m ² |

Electrical description

| | |
|------------------|--|
| Power supply | 220-240V / 50-60 Hz |
| Driver / Ballast | Integral EC electronic converter. DALI |
| Power factor | > 0.9 |
| Surge protection | In-pole surge protection SP10 device supplied. Please refer to WE-EF installation instructions for details. Use suffix +A for Integral surge protection. |

Additional information

| | |
|----------|------------------------|
| Lifetime | Ta=40° L70B50 > 50000h |
|----------|------------------------|

WE-EF LIGHTING Pty Ltd

6/13 Downard Street, 3195 Braeside, Victoria - Phone: +61 3 8587 0444 - Fax: +61 3 8587 0499

info.australia@we-ef.com - <https://we-ef.com/aus>

Subject to technical changes and errors. - Generated on 23/11/2024

127-1217

ALP534-FT LED

we-ef

Control

Eco Step Dim® Basic

| Description | Part ID |
|-------------------------|----------|
| Eco Step Dim® Basic LED | 430-0001 |

Eco Step Dim® Advanced

| Description | Part ID |
|----------------------------|----------|
| Eco Step Dim® Advanced LED | 430-0002 |

WE-EF LIGHTING Pty Ltd

6/13 Downard Street, 3195 Braeside, Victoria - Phone: +61 3 8587 0444 - Fax: +61 3 8587 0499

info.australia@we-ef.com - <https://we-ef.com/aus>

Subject to technical changes and errors. - Generated on 23/11/2024

Mounting Accessories

Wall and pole brackets BA

| Description | Part ID | C1 | D x L1 | H1 | H2 | M1 | Weight (kg) | C | H |
|------------------------------|----------|-----|--------|------|-----|----|-------------|-----|------|
| BA0-420 Wall bracket, single | 300-0152 | 460 | | 1000 | 132 | 9 | 2 | 460 | 1000 |

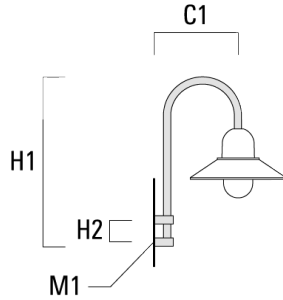

| | | | | | | | | | |
|------------------------------|----------|-----|---------|------|--|--|---|-----|------|
| BA1-420 Pole bracket, single | 300-0099 | 420 | 76 x 80 | 1000 | | | 4 | 420 | 1000 |
|------------------------------|----------|-----|---------|------|--|--|---|-----|------|

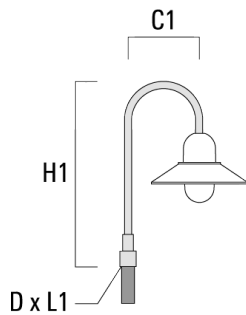

ALP534-FT LED

| Description | Part ID | C1 | D x L1 | H1 | H2 | M1 | Weight (kg) | C | H |
|------------------------------|----------|-----|---------|------|----|----|-------------|-----|------|
| BA2-420 Pole bracket, double | 300-0104 | 500 | 76 x 80 | 1000 | | | 8 | 500 | 1000 |

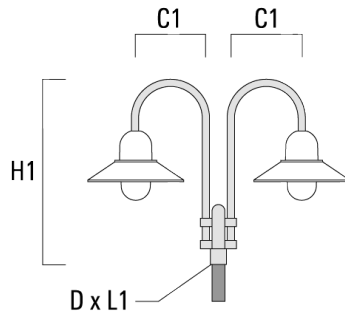

| | | | | | | | | | |
|------------------------------|----------|-----|---------|------|--|--|----|-----|------|
| BA3-420 Pole bracket, triple | 300-0109 | 500 | 76 x 80 | 1000 | | | 10 | 500 | 1000 |
|------------------------------|----------|-----|---------|------|--|--|----|-----|------|

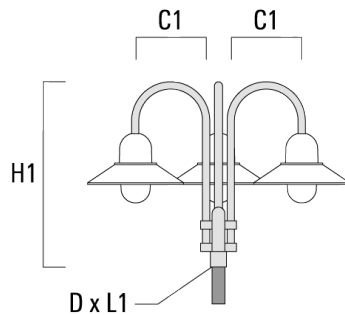

Wall and pole brackets BC

| Description | Part ID | C1 | H1 | H2 | M1 | Weight (kg) | C | H |
|------------------------------|----------|-----|------|-----|----|-------------|-----|------|
| BC0-420 Wall bracket, single | 300-0808 | 460 | 1230 | 300 | 8 | 2.30 | 460 | 1230 |

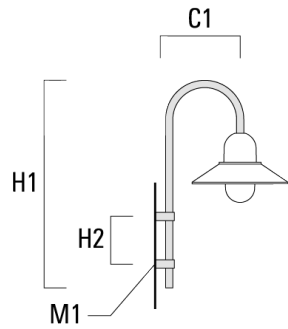

| | | | | | | | | |
|------------------------------|----------|-----|------|-----|---|------|-----|------|
| BC1-420 Pole bracket, single | 300-0768 | 500 | 1230 | 300 | 8 | 2.30 | 500 | 1230 |
|------------------------------|----------|-----|------|-----|---|------|-----|------|

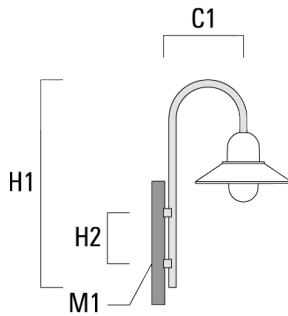

ALP534-FT LED

| Description | Part ID | C1 | H1 | H2 | M1 | Weight (kg) | C | H |
|------------------------------|----------|-----|------|-----|----|-------------|-----|------|
| BC2-420 Pole bracket, double | 300-0767 | 500 | 1230 | 300 | 8 | 4.60 | 500 | 1230 |

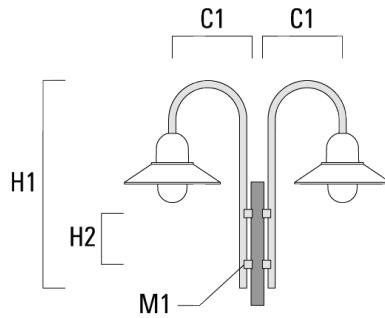

Wall and pole brackets DA

| Description | Part ID | C1 | C2 | D × L1 | H1 | Weight (kg) | C | H |
|------------------------------|----------|-----|----|--------|-----|-------------|-----|-----|
| DA0-500 Wall bracket, single | 300-0146 | 510 | 70 | | 650 | 5.70 | 510 | 650 |

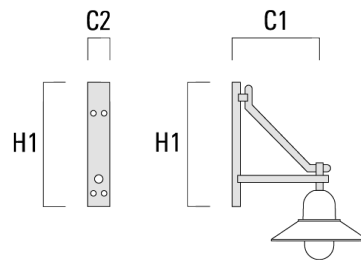

ALP534-FT LED

| Description | Part ID | C1 | C2 | D x L1 | H1 | Weight (kg) | C | H |
|------------------------------|----------|-----|----|---------|-----|-------------|-----|-----|
| DA1-500 Pole bracket, single | 300-0138 | 510 | | 76 x 80 | 700 | 5.70 | 510 | 700 |

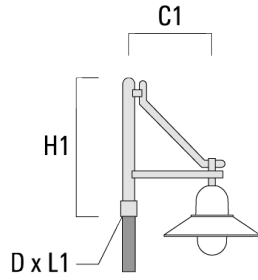

| | | | | | | | | |
|------------------------------|----------|-----|--|---------|-----|------|-----|-----|
| DA2-500 Pole bracket, double | 300-0141 | 510 | | 76 x 80 | 700 | 8.30 | 510 | 700 |
|------------------------------|----------|-----|--|---------|-----|------|-----|-----|

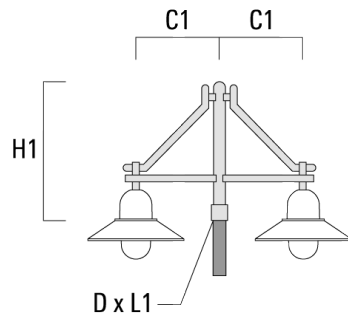

ALP534-FT LED

| Description | Part ID | C1 | C2 | D × L1 | H1 | Weight (kg) | C | H |
|------------------------------|----------|-----|----|---------|-----|-------------|-----|-----|
| DA3-500 Pole bracket, triple | 300-0144 | 510 | | 76 x 80 | 700 | 10.90 | 510 | 700 |

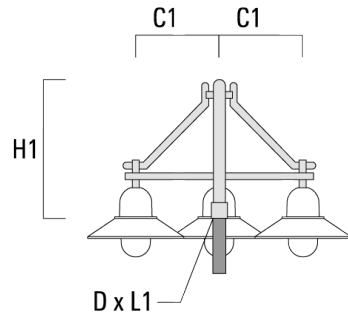

Wall and pole brackets DB

| Description | Part ID | C1 | C2 | D × L1 | H1 | Weight (kg) | C | H |
|------------------------------|----------|-----|----|--------|-----|-------------|-----|-----|
| DB0-500 Wall bracket, single | 300-0169 | 510 | 70 | | 650 | 5.50 | 510 | 650 |

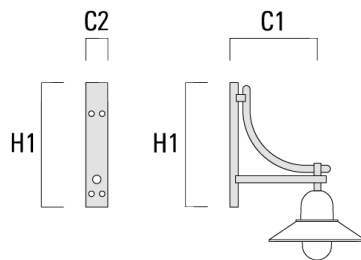

ALP534-FT LED

| Description | Part ID | C1 | C2 | D x L1 | H1 | Weight (kg) | C | H |
|------------------------------|----------|-----|----|---------|-----|-------------|-----|-----|
| DB1-500 Pole bracket, single | 300-0190 | 510 | | 76 x 80 | 700 | 5.50 | 510 | 700 |

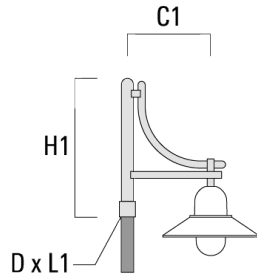

| | | | | | | | | |
|------------------------------|----------|-----|--|---------|-----|------|-----|-----|
| DB2-500 Pole bracket, double | 300-0191 | 510 | | 76 x 80 | 700 | 7.90 | 510 | 700 |
|------------------------------|----------|-----|--|---------|-----|------|-----|-----|

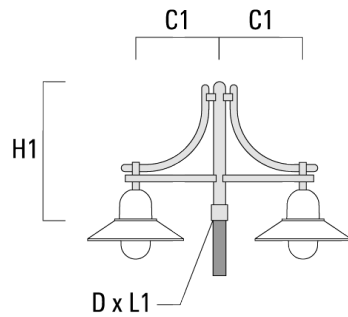

ALP534-FT LED

| Description | Part ID | C1 | C2 | D × L1 | H1 | Weight (kg) | C | H |
|------------------------------|----------|-----|----|---------|-----|-------------|-----|-----|
| DB3-500 Pole bracket, triple | 300-0192 | 510 | | 76 x 80 | 700 | 10.30 | 510 | 700 |

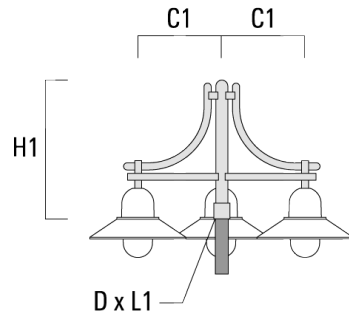

Wall and pole brackets DS

| Description | Part ID | C1 | C2 | D × L1 | H1 | Weight (kg) | C | H |
|------------------------------|----------|-----|----|--------|-----|-------------|-----|-----|
| DS0-500 Wall bracket, single | 300-0064 | 510 | 70 | | 650 | 2.50 | 510 | 650 |

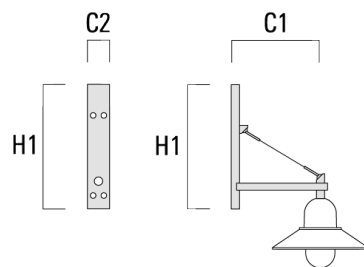

ALP534-FT LED

| Description | Part ID | C1 | C2 | D x L1 | H1 | Weight (kg) | C | H |
|------------------------------|----------|-----|----|---------|-----|-------------|-----|-----|
| DS1-500 Pole bracket, single | 300-0063 | 510 | | 76 x 80 | 725 | 3.90 | 510 | 725 |

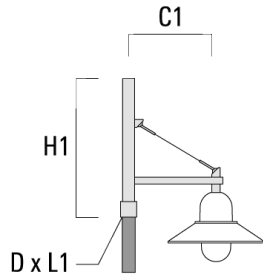

| | | | | | | | | |
|------------------------------|----------|-----|--|---------|-----|------|-----|-----|
| DS2-500 Pole bracket, double | 300-0066 | 510 | | 76 x 80 | 725 | 5.30 | 510 | 725 |
|------------------------------|----------|-----|--|---------|-----|------|-----|-----|

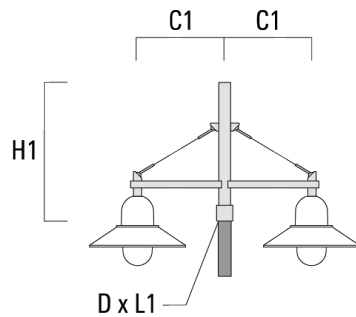

127-1217

ALP534-FT LED

we-ef

| Description | Part ID | C1 | C2 | D x L1 | H1 | Weight (kg) | C | H |
|------------------------------|----------|-----|----|---------|-----|-------------|-----|-----|
| DS3-500 Pole bracket, triple | 300-0069 | 510 | | 76 x 80 | 725 | 6.70 | 510 | 725 |

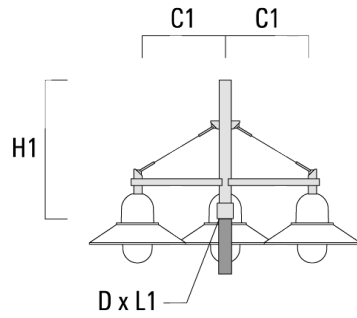

WE-EF LIGHTING Pty Ltd

6/13 Downard Street, 3195 Braeside, Victoria - Phone: +61 3 8587 0444 - Fax: +61 3 8587 0499

info.australia@we-ef.com - <https://we-ef.com/aus>

Subject to technical changes and errors. - Generated on 23/11/2024