

132-0524

OLV330 LED

we-ef



Description

IP65. Surface mounted wallwasher. Suitable for installation over 4" recessed junction box in uplight or downlight position. Optional 2200 K version available. To be specified at time of ordering.

Weight	14.60 lb
Light distribution	symmetric, very narrow beam, 'sharp cut-off' [VNS]
Light source	LED-12/12W / 350 mA - 3000 K
CRI	80
Power supply	electronic gear
BUG	B2 U0 G0
LEDs	12
Rated input power	13.9 W
Nominal Lumen (lm)	
LED Lumen	155
Total Lumen	1860
Tj	85
Rated lumens (lm)	
LED Lumen	137.1
Total Lumen	1645.1
Ta	25

WE-EF LIGHTING USA, LLC

410-D Keystone Drive, 15086 Warrendale, PA 15086 - Phone: +1 724 742 0030
customersupport.usa@we-ef.com - <https://we-ef.com/us>
Subject to technical changes and errors. - Generated on 11/23/2024

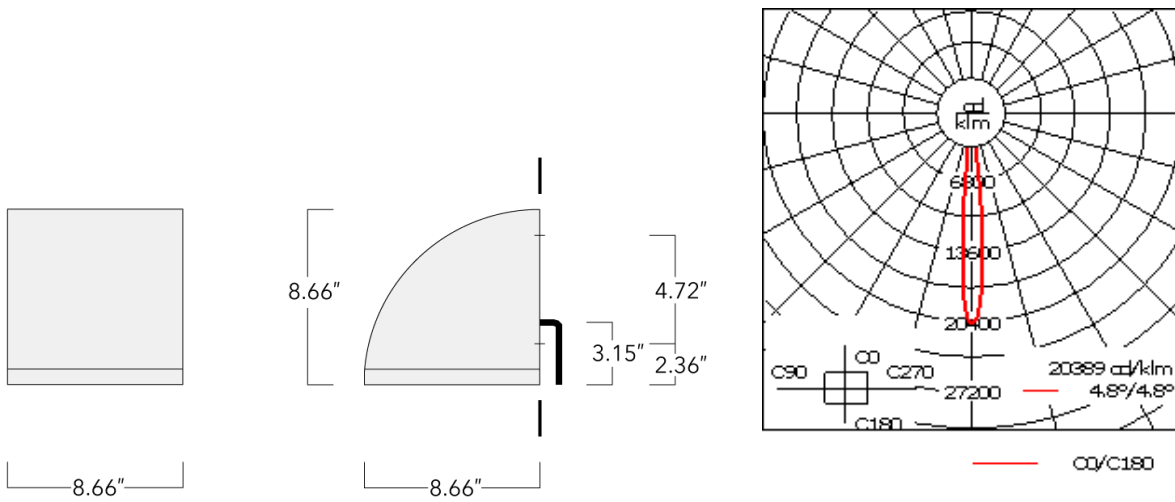

Specifications

Material description

Body	Luminaire body and lens frame constructed in die cast aluminum.
Lens	Tempered glass lens.
Colors	<div style="display: flex; flex-direction: column; gap: 5px;"> <div style="display: flex; align-items: center;"> <div style="width: 20px; height: 10px; background-color: black; margin-right: 5px;"></div> RAL9004 Black </div> <div style="display: flex; align-items: center;"> <div style="width: 20px; height: 10px; background-color: grey; margin-right: 5px;"></div> RAL9007 Grey Metallic </div> <div style="display: flex; align-items: center;"> <div style="width: 20px; height: 10px; background-color: white; margin-right: 5px;"></div> RAL9016 White </div> <div style="display: flex; align-items: center;"> <div style="width: 20px; height: 10px; background-color: darkgrey; margin-right: 5px;"></div> RAL8019 Dark Bronze </div> </div>
Gasket	Silicone rubber gasket
Fasteners	PCS polymer coated stainless steel
Ingress protection	IP65
Impact resistance	IK07
Corrosion resistance	5CE

Electrical description

Power supply	Integral [ECG] electronic driver 120V-277V. 0-10V dimmable, to be specified with order.
Driver / Ballast	Integral EC electronic converter

WE-EF LIGHTING USA, LLC

410-D Keystone Drive, 15086 Warrendale, PA 15086 - Phone: +1 724 742 0030
 customersupport.usa@we-ef.com - <https://we-ef.com/us>
 Subject to technical changes and errors. - Generated on 11/23/2024

132-0524

OLV330 LED

we-ef

Additional information

Lifetime	Ta=25°/40° L90B10 > 90000h
BUG Rating	Please see individual Spec Sheets for classification of Backlight, Uplight and Glare.
Listings	ETL listed. Suitable for wet locations.

WE-EF LIGHTING USA, LLC

410-D Keystone Drive, 15086 Warrendale, PA 15086 - Phone: +1 724 742 0030
customersupport.usa@we-ef.com - <https://we-ef.com/us>
Subject to technical changes and errors. - Generated on 11/23/2024

Mounting Accessories

Surface Collar

Description	Part ID	A	B	C1	D1	D2	Weight (lb)
OLV33_Surface Collar	132-6001	8.69	8.63	1.75	∅1	∅2	1.12

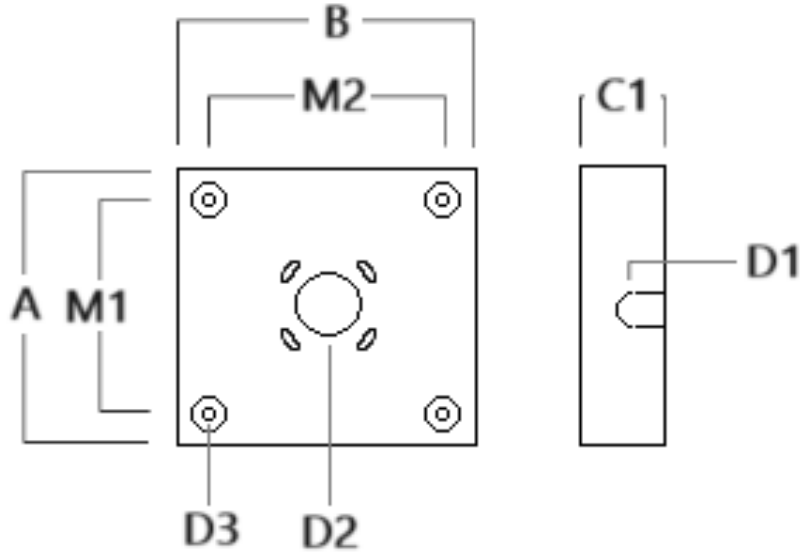

132-0524

OLV330 LED

we-ef

Electrical Accessories

Emergency Lighting Package

Description	Part ID	Additional information
OLV33_LED Emergency Lighting Package	132-6900	Emergency battery backup operating for a minimum of 90 minutes, at full power, when main power is lost.

WE-EF LIGHTING USA, LLC

410-D Keystone Drive, 15086 Warrendale, PA 15086 - Phone: +1 724 742 0030
customersupport.usa@we-ef.com - <https://we-ef.com/us>

Subject to technical changes and errors. - Generated on 11/23/2024