

133-0347

STL259 LED

we-ef

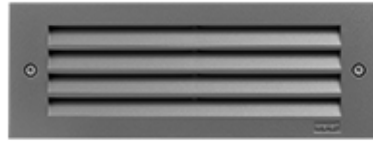

Description

Louvred Steplight.

ADA (American Disabilities Act) Compliant.

IP55. Class I. IK10. Marine-grade, die-cast aluminum alloy. 5CE superior corrosion protection including PCS hardware. Silicone CCG® Controlled Compression Gasket. Opal polycarbonate main lens. Two cable entries. Integral driver. Factory-installed LED circuit board. 0-10V Dimming standard.

A pre-installation blackout is available and recommended for mounting in concrete walls; to be ordered separately.

Specify product with 7 Digit product code - Finish Color. Accessories, such as mounting, optical, and electrical, must be specified separately.

Example: XXX-XXXX-9004 (Black)

+ XXX-XXXX (Accessory 1)

Weight	2.90 lb
Light distribution	diffused distribution
Light source	LED-6/6W / 350 mA - 4000 K
CRI	80
Power supply	electronic gear
LEDs	6
Rated input power	7.5 W

Nominal Lumen (lm)

LED Lumen	170
Total Lumen	1020
Tj	85

Rated lumens (lm)

LED Lumen	4.7
Total Lumen	28.1
Ta	25

WE-EF LIGHTING USA, LLC

410-D Keystone Drive, 15086 Warrendale, PA 15086 - Phone: +1 724 742 0030

customersupport.usa@we-ef.com - <https://we-ef.com/us>

Subject to technical changes and errors. - Generated on 11/23/2024

133-0347

STL259 LED

we-ef

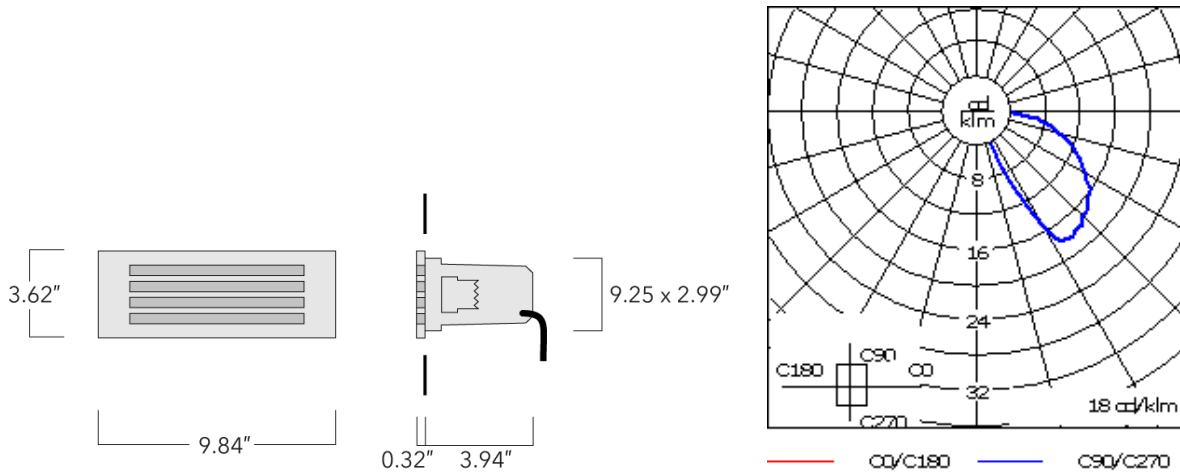

Specifications

Material description

Body	Luminaire body and lens frame constructed in die cast aluminum.
Lens	Opal polycarbonate lens.
Colors	<ul style="list-style-type: none"> RAL9004 Black RAL9007 Grey Metallic RAL9016 White RAL8019 Dark Bronze
Gasket	Silicone rubber gasket
Fasteners	PCS polymer coated stainless steel
Ingress protection	IP55
Impact resistance	IK10
Corrosion resistance	5CE

Electrical description

Power supply	Integral [ECG] electronic driver 120V-277V. 0-10V dimmable, to be specified with order.
Driver / Ballast	Integral EC electronic converter

WE-EF LIGHTING USA, LLC

410-D Keystone Drive, 15086 Warrendale, PA 15086 - Phone: +1 724 742 0030

customersupport.usa@we-ef.com - <https://we-ef.com/us>

Subject to technical changes and errors. - Generated on 11/23/2024

133-0347

STL259 LED

we-ef

Additional information

Lifetime	Ta=25°/40° L80B10 > 54000h
Listings	ETL listed. Suitable for wet locations.

WE-EF LIGHTING USA, LLC

410-D Keystone Drive, 15086 Warrendale, PA 15086 - Phone: +1 724 742 0030
customersupport.usa@we-ef.com - <https://we-ef.com/us>
Subject to technical changes and errors. - Generated on 11/23/2024

133-0347

STL259 LED

we-ef

Mounting Accessories

Installation blackout

Description	Part ID	A	B	C1	C
Installation blackout BST25-I	133-0076	10.51"	5.19"	5.12"	130

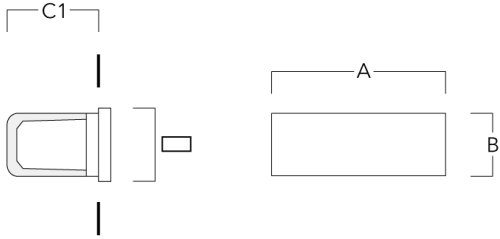

WE-EF LIGHTING USA, LLC

410-D Keystone Drive, 15086 Warrendale, PA 15086 - Phone: +1 724 742 0030
customersupport.usa@we-ef.com - <https://we-ef.com/us>

Subject to technical changes and errors. - Generated on 11/23/2024