

**133-0348**  
**STX259 LED**

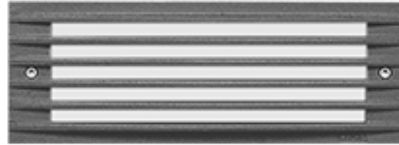

**Description**

Recessed Wall Luminaire.

ADA (American Disabilities Act) Compliant.

IP55. Class I. Marine-grade, die-cast aluminum alloy. 5CE superior corrosion protection including PCS hardware. Silicone CCG® Controlled Compression Gasket. Polycarbonate main lens. Two cable entries. 0-10V Dimming standard.

A pre-installation blockout is available and recommended for mounting in concrete walls; to be ordered separately.

Specify product with 7 Digit product code - Finish Color. Accessories, such as mounting, optical, and electrical, must be specified separately.

Example: XXX-XXXX-9004 (Black)  
+ XXX-XXXX (Accessory 1)

Weight	2.90 lb
Light distribution	diffused distribution
Light source	LED-6/6W / 350 mA - 3000 K
CRI	80
Power supply	electronic gear
LEDs	6
Rated input power	7.5 W

**Nominal Lumen (lm)**

LED Lumen	155
Total Lumen	930
Tj	85

**Delivered lumens (lm)**

LED Lumen	18.8
Total Lumen	112.7
Ta	25

**WE-EF LIGHTING USA, LLC**

410-D Keystone Drive, 15086 Warrendale, PA 15086 - Phone: +1 724 742 0030  
customersupport.usa@we-ef.com - <https://we-ef.com/us>  
Subject to technical changes and errors. - Generated on 08/16/2025

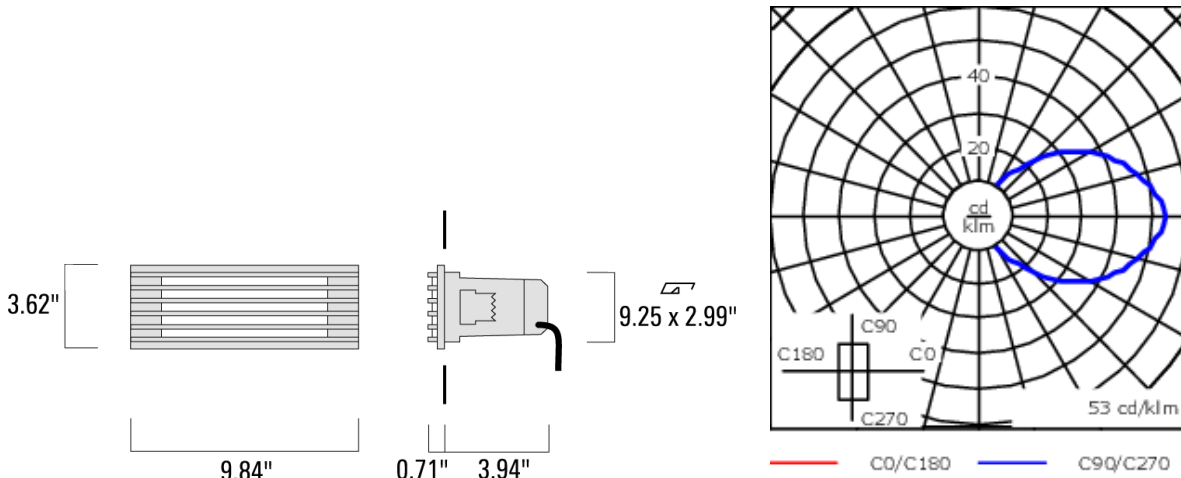

## Specifications

### Material description

Body	Luminaire body and lens frame constructed in die cast aluminum.
Lens	Opal polycarbonate lens.
Colors	<ul style="list-style-type: none"> <li><span style="display: inline-block; width: 15px; height: 15px; background-color: black; margin-right: 5px;"></span> RAL9004 Black</li> <li><span style="display: inline-block; width: 15px; height: 15px; background-color: grey; margin-right: 5px;"></span> RAL9007 Grey Metallic</li> <li><span style="display: inline-block; width: 15px; height: 15px; background-color: white; margin-right: 5px;"></span> RAL9016 White</li> <li><span style="display: inline-block; width: 15px; height: 15px; background-color: darkgrey; margin-right: 5px;"></span> RAL8019 Dark Bronze</li> </ul>
Gasket	Silicone rubber gasket
Fasteners	PCS polymer coated stainless steel
Ingress protection	IP55
Impact resistance	IK10
Corrosion resistance	5CE

### Electrical description

Power supply	Integral [ECG] electronic driver 120V-277V. 0-10V dimmable, to be specified with order.
--------------	---

**WE-EF LIGHTING USA, LLC**

410-D Keystone Drive, 15086 Warrendale, PA 15086 - Phone: +1 724 742 0030  
 customersupport.usa@we-ef.com - <https://we-ef.com/us>  
 Subject to technical changes and errors. - Generated on 08/16/2025

**133-0348**

**STX259 LED**

**we-ef**

**Additional information**

---

Lifetime LED >60,000 h Ta 25°(B10/70)<br>  
Control gear >50,000 h Ta 25°

Listings ETL listed. Suitable for wet locations.

---

**WE-EF LIGHTING USA, LLC**

410-D Keystone Drive, 15086 Warrendale, PA 15086 - Phone: +1 724 742 0030  
customersupport.usa@we-ef.com - <https://we-ef.com/us>

Subject to technical changes and errors. - Generated on 08/16/2025