



Description

IP66, Class I. IK07. Marine-grade, die-cast aluminium alloy. 5CE superior corrosion protection + primer including PCS hardware. Silicone rubber gasket. Safety glass lens, hinged. Frame with safety catch. Two cable entries. Integral EC electronic converter in thermally separated compartment. CAD-optimised optics for superior illumination and glare control. OLC_R_ One LED Concept. Factory installed LED circuit board.

A pre-installation blockout, proud or flush, is available and recommended for mounting in concrete ceilings. To be ordered separately.

2700 K option available on request.

Weight	4.00 kg
Light distribution	symmetric, very narrow beam [EE]
Light source	LED-24/48W / 700 mA - 4000 K
CRI	80
Power supply	EC
LEDs	24
Rated input power	54 W
Nominal Lumen (lm)	
LED Lumen	310
Total Lumen	7440
Tj	85
Rated lumens (lm)	
LED Lumen	266.6
Total Lumen	6398.9
Ta	25

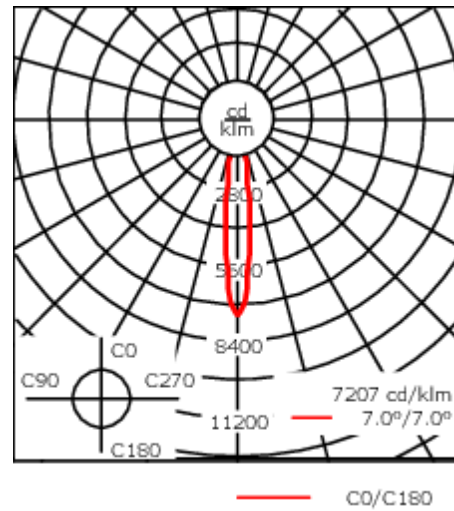
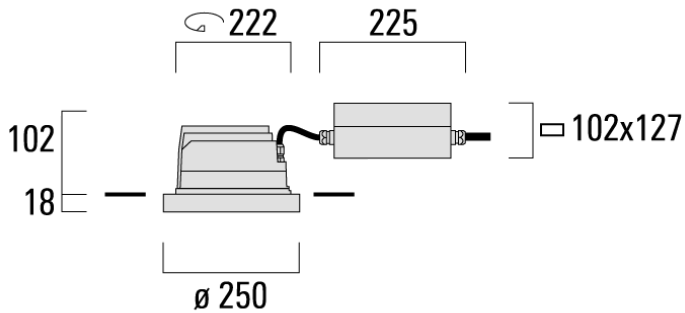

Specifications

Material description

Body	Marine-grade die-cast aluminium alloy
Lens	Safety glass lens, hinged
Colours	<div style="display: flex; align-items: center; gap: 10px;"> <div style="width: 20px; height: 15px; background-color: black; margin-right: 5px;"></div> RAL9004 Signal black </div> <div style="display: flex; align-items: center; gap: 10px; margin-top: 5px;"> <div style="width: 20px; height: 15px; background-color: #cccccc; margin-right: 5px;"></div> RAL9006 White aluminium </div> <div style="display: flex; align-items: center; gap: 10px; margin-top: 5px;"> <div style="width: 20px; height: 15px; background-color: #808080; margin-right: 5px;"></div> RAL9007 Grey aluminium </div> <div style="display: flex; align-items: center; gap: 10px; margin-top: 5px;"> <div style="width: 20px; height: 15px; background-color: #e0e0e0; margin-right: 5px;"></div> RAL9016 Traffic white </div>
Gasket	Silicone rubber gasket
Fasteners	PCS Polymer Coated Stainless Steel Hardware (unpainted)
Ingress protection	IP66
Impact resistance	IK07
Corrosion resistance	5CE+Primer

Electrical description

Power supply	230V / 50 Hz
Driver / Ballast	Integral EC electronic converter in thermally-separated compartment

134-1401

DOC240 LED

we-ef

Additional information

Lifetime Ta=40° L90B10 > 90000h

Warranty The product is supplied with 10-year warranty. Please refer to the LED Warranty Statement located on www.we-ef.com for further details.

WE-EF LIGHTING Pty Ltd

6/13 Downard Street, 3195 Braeside, Victoria - Phone: +61 3 8587 0444 - Fax: +61 3 8587 0499

info.australia@we-ef.com - <https://we-ef.com/aus>

Subject to technical changes and errors. - Generated on 23/11/2024

134-1401

DOC240 LED

we-ef

Control

DALI interface

Description	Part ID	C
DALI interface	430-0013	90

WE-EF LIGHTING Pty Ltd

6/13 Downard Street, 3195 Braeside, Victoria - Phone: +61 3 8587 0444 - Fax: +61 3 8587 0499

info.australia@we-ef.com - <https://we-ef.com/aus>

Subject to technical changes and errors. - Generated on 23/11/2024

Mounting Accessories

Installation blackout, flush - reduced depth

Description	Part ID	A	B	C1
Installation blackout BDO24-II-RE	134-1714	574	305	227

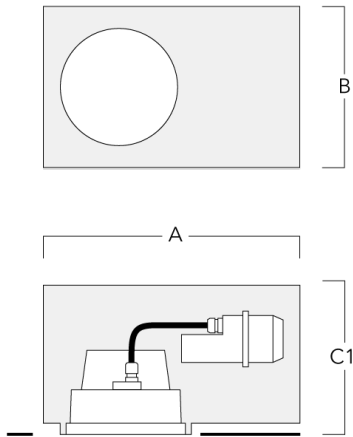

Installation blackout, proud - reduced depth

Description	Part ID	A	B	C1
Installation blackout BDO24-I-RE	134-1717	574	305	209

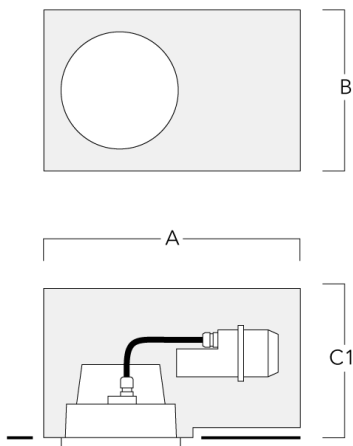

Installation blackout, flush with shadow line - reduced depth

Description	Part ID	A	B	C1
Installation blackout BDO24-III-RE	134-1718	573	305	227

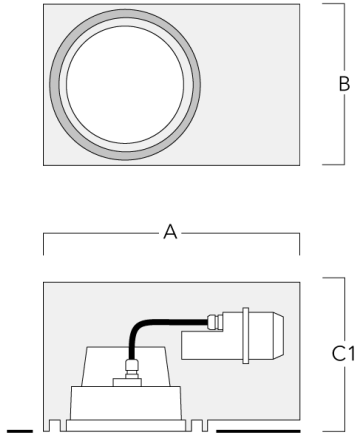

134-1401

DOC240 LED

we-ef

Optical Accessories

Wallwash lens

Description	Part ID	C1
IO-20-WW-DAC/DOC240-LED	134-1492	191

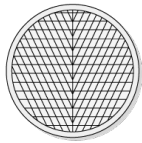

Linear spread lens

Description	Part ID	C1
IO-180-DAC/DOC240-LED	134-1382	191

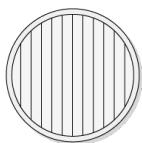

WE-EF LIGHTING Pty Ltd

6/13 Downard Street, 3195 Braeside, Victoria - Phone: +61 3 8587 0444 - Fax: +61 3 8587 0499

info.australia@we-ef.com - <https://we-ef.com/aus>

Subject to technical changes and errors. - Generated on 23/11/2024