



Description

IP55. IK07. Marine-grade, die-cast aluminium alloy. 5CE superior corrosion protection including PCS hardware. Safety glass lens. Silicone CCG® Controlled Compression Gasket.

Integral EC electronic converter in thermally-separated compartment. Advanced thermal management protects LEDs while optimising lumens output. CAD-optimised optics for superior illumination and glare control. OLC® One LED Concept.

| | |
|---------------------------|----------------------------------|
| Weight | 1.60 kg |
| Light distribution | symmetric, very narrow beam [EE] |
| Light source | LED-6/12W / 700 mA - 4000 K |
| CRI | 80 |
| Power supply | EC |
| LEDs | 6 |
| Rated input power | 14.5 W |
| Nominal Lumen (lm) | |
| LED Lumen | 310 |
| Total Lumen | 1860 |
| T _j | 85 |
| Rated lumens (lm) | |
| LED Lumen | 266.6 |
| Total Lumen | 1599.7 |
| T _a | 25 |

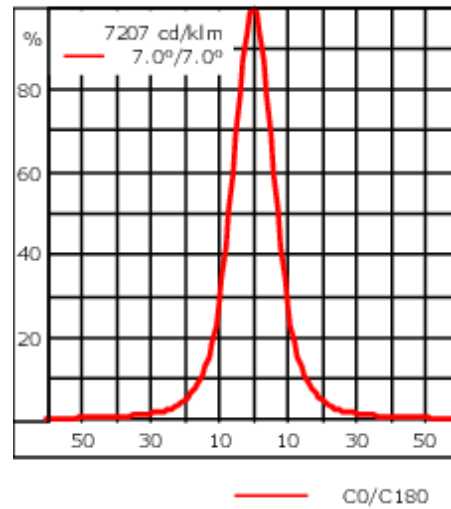
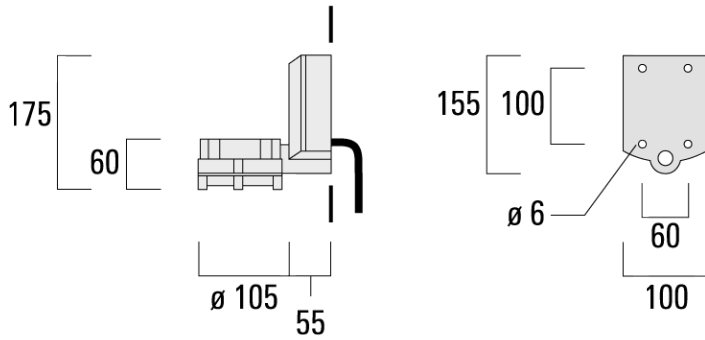

Specifications
Material description

| | |
|----------------------|--|
| Body | Marine-grade, die-cast aluminium alloy |
| Lens | Safety glass lens |
| Colours | <div style="display: flex; align-items: center; gap: 10px;"> <div style="width: 20px; height: 15px; background-color: black; margin-right: 5px;"></div> RAL9004 Signal black <div style="width: 20px; height: 15px; background-color: #808080; margin-right: 5px;"></div> RAL9007 Grey aluminium <div style="width: 20px; height: 15px; background-color: #404040; margin-right: 5px;"></div> RAL7016 Anthracite grey <div style="width: 20px; height: 15px; background-color: #e0e0e0; margin-right: 5px;"></div> RAL9016 Traffic white </div> |
| Gasket | Silicone CCG® Controlled Compression Gasket |
| Fasteners | PCS hardware |
| Ingress protection | IP55 |
| Impact resistance | IK07 |
| Corrosion resistance | 5CE |

Electrical description

| | |
|------------------|---|
| Driver / Ballast | Integral EC electronic converter in thermally-separated compartment |
|------------------|---|

Additional information

WE-EF LIGHTING (Thailand) Co., Ltd.

57 Moo 5, Kingkaew Rd., Bangplee, 10540 Samutprakarn - Phone: +66 2 738 96 20 - Fax: +66 2 738 96 29

<https://we-ef.com/asia>

Subject to technical changes and errors. - Generated on 15/08/2025

145-9378

FLC122 LED

we-ef

Optical Accessories

Snoot

| Description | Part ID | A | C1 |
|-------------|----------|----|-----|
| Snoot ET | 145-0030 | 60 | 120 |

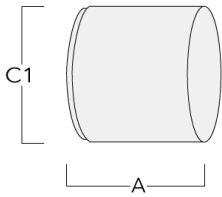

Glare shield

| Description | Part ID | A | C1 |
|-----------------|----------|-----|-----|
| Glare shield ES | 145-9192 | 102 | 119 |

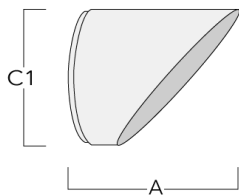

WE-EF LIGHTING (Thailand) Co., Ltd.

57 Moo 5, Kingkaew Rd., Bangplee, 10540 Samutprakarn - Phone: +66 2 738 96 20 - Fax: +66 2 738 96 29

<https://we-ef.com/asia>

Subject to technical changes and errors. - Generated on 15/08/2025