

195-9546

DLB239 LED

**we-ef**



#### Description

IP55. Class I. IK10. Marine-grade, die-cast aluminum alloy. 5CE superior corrosion protection including PCS hardware. Silicone CCG® Controlled Compression Gasket. Polycarbonate main lens. Integral driver. Factory-installed LED circuit board. 0-10V Dimming comes standard with luminaire.

Suitable for installation on ceiling or wall over 4" recessed junction box.

Specify product with 7 Digit product code - Finish Color. Accessories, such as mounting, optical, and electrical, must be specified separately.

Example: XXX-XXXX-9004 (Black)

+ XXX-XXXX (Accessory 1)

Weight	8.00 lb
Light distribution	diffused distribution
Light source	LED-FT-28W / 800 mA - 4000 K
CRI	80
Power supply	electronic gear
LEDs	1
Rated input power	31 W

#### Rated lumens (lm)

LED Lumen	1250.9
Total Lumen	1250.9
Ta	25

#### Nominal Lumen (lm)

LED Lumen	4970
Total Lumen	4970
Tc	25

#### WE-EF LIGHTING USA, LLC

410-D Keystone Drive, 15086 Warrendale, PA 15086 - Phone: +1 724 742 0030

customersupport.usa@we-ef.com - <https://we-ef.com/us>

Subject to technical changes and errors. - Generated on 10/23/2024

# 195-9546

## DLB239 LED

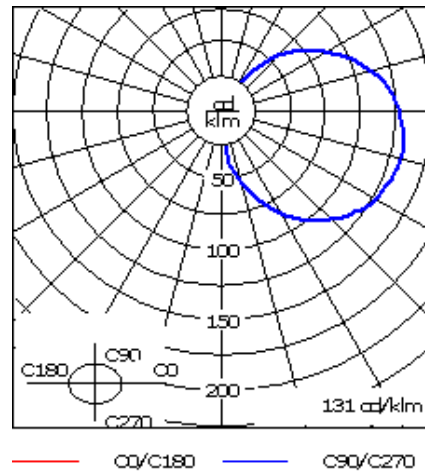
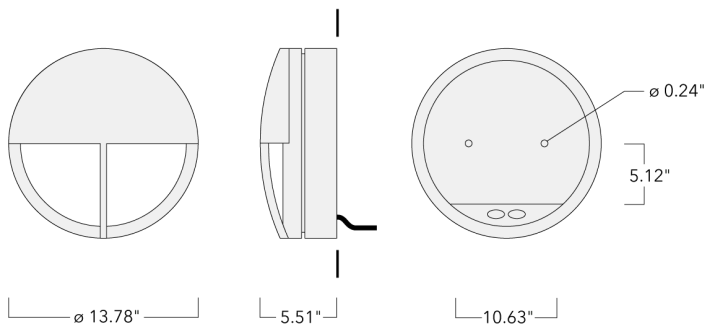

### Specifications

#### Material description

Body	Luminaire body and lens frame constructed in die cast aluminum.
Lens	Opal polycarbonate lens.
Colors	<ul style="list-style-type: none"><li>■ RAL9004 Black</li><li>■ RAL9007 Grey Metallic</li><li>■ RAL9016 White</li><li>■ RAL8019 Dark Bronze</li></ul>
Gasket	Silicone rubber gasket
Fasteners	PCS polymer coated stainless steel
Ingress protection	IP55
Impact resistance	IK10
Corrosion resistance	5CE

#### Electrical description

Power supply	Integral [ECG] electronic driver 120V-277V. 0-10V dimmable, to be specified with order.
Driver / Ballast	Integral EC electronic converter

#### Additional information

Lifetime	Ta=25°/40° L70B50 > 50000h
Listings	ETL, UL-1598, CSA-C22.2#250.0. Suitable for Wet Locations.

#### WE-EF LIGHTING USA, LLC

410-D Keystone Drive, 15086 Warrendale, PA 15086 - Phone: +1 724 742 0030  
customersupport.usa@we-ef.com - <https://we-ef.com/us>  
Subject to technical changes and errors. - Generated on 10/23/2024

**195-9546**

**DLB239 LED**

**WE-EF LIGHTING USA, LLC**

410-D Keystone Drive, 15086 Warrendale, PA 15086

Phone: +1 724 742 0030

[customersupport.usa@we-ef.com](mailto:customersupport.usa@we-ef.com)

<https://we-ef.com/us>

Subject to technical changes and errors.

Generated on 10/23/2024

**we-ef**

---

A Fagerhult Group Company