



Description

IP66, Class I. IK07. Marine-grade, die-cast aluminium alloy. 5CE superior corrosion protection + primer including PCS hardware. Silicone rubber gasket. Safety glass lens, hinged. Frame with safety catch. Two cable entries. Integral EC electronic converter in thermally separated compartment. CAD-optimised optics for superior illumination and glare control. OLC_R_ One LED Concept. Factory installed LED circuit board.

A pre-installation blockout, proud or flush, is available and recommended for mounting in concrete ceilings. To be ordered separately.

2700 K option available on request. Optional 2200 K version available. To be specified at time of ordering.

Weight	2.10 kg
Light distribution	wallwash [A20]
Light source	LED-12/24W / 700 mA - 3000 K
CRI	80
Power supply	EC
LEDs	12
Rated input power	27 W

Nominal Lumen (lm)

LED Lumen	290
Total Lumen	3480
Tj	85

Rated lumens (lm)

LED Lumen	200.5
Total Lumen	2405.6
Ta	25

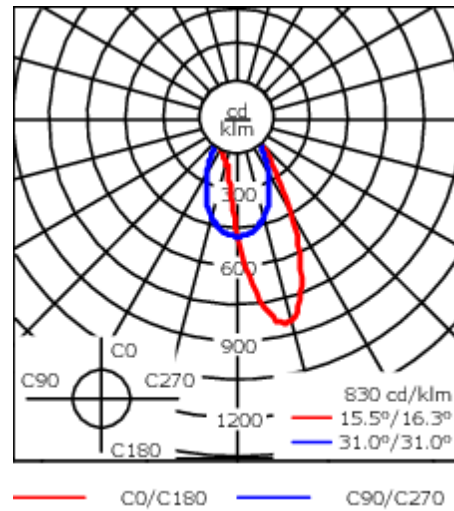
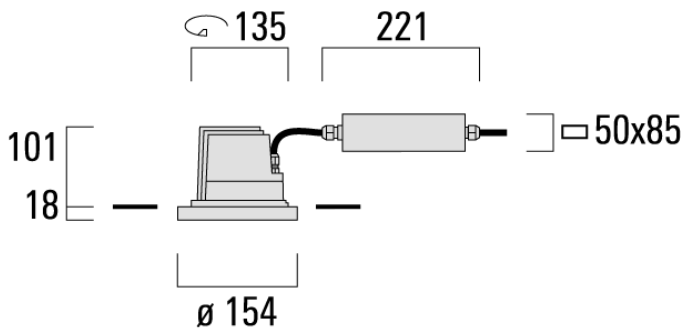

Specifications

Material description

Body	Marine-grade, die-cast aluminium alloy
Lens	Safety glass lens, hinged
Colours	<div style="display: flex; align-items: center;"> <div style="width: 20px; height: 15px; background-color: black; margin-right: 5px;"></div> <div>RAL9004 Signal black</div> </div> <div style="display: flex; align-items: center; margin-top: 5px;"> <div style="width: 20px; height: 15px; background-color: #cccccc; margin-right: 5px;"></div> <div>RAL9006 White aluminium</div> </div> <div style="display: flex; align-items: center; margin-top: 5px;"> <div style="width: 20px; height: 15px; background-color: #808080; margin-right: 5px;"></div> <div>RAL9007 Grey aluminium</div> </div> <div style="display: flex; align-items: center; margin-top: 5px;"> <div style="width: 20px; height: 15px; background-color: #e0e0e0; margin-right: 5px;"></div> <div>RAL9016 Traffic white</div> </div>
Gasket	Silicone rubber gasket
Fasteners	PCS Polymer Coated Stainless Steel Hardware (unpainted)
Ingress protection	IP66
Impact resistance	IK07
Corrosion resistance	5CE+Primer

134-1210+134-1491

we-ef

DOC220 LED

Electrical description

Power supply	230V / 50 Hz
Driver / Ballast	Integral EC electronic converter in thermally-separated compartment

Additional information

Lifetime	Ta=40° L90B10 > 90000h
Warranty	The product is supplied with 10-year warranty. Please refer to the LED Warranty Statement located on www.we-ef.com for further details.

WE-EF LIGHTING Pty Ltd

6/13 Downard Street, 3195 Braeside, Victoria - Phone: +61 3 8587 0444 - Fax: +61 3 8587 0499

info.australia@we-ef.com - <https://we-ef.com/aus>

Subject to technical changes and errors. - Generated on 23/11/2024

Mounting Accessories

Installation blackout, proud

Description	Part ID	A	B	C1	C
Installation blackout BDO22-I	134-0797	383	200	209	195

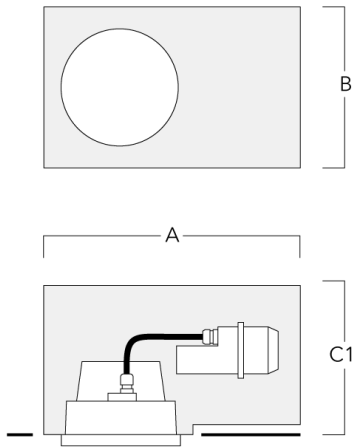

Installation blackout, flush

Description	Part ID	A	B	C1	C
Installation blackout BDO22-II	134-1161	383	200	227	195

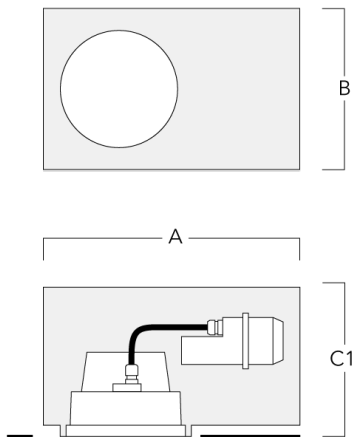

DOC220 LED

Optical Accessories

Surface wash lens

Description	Part ID	C1
IO-360-DAC/DOC220-LED	134-1440	105

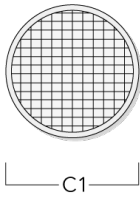

Wallwash lens

Description	Part ID	C1
IO-20-WW-DAC/DOC220-LED	134-1491	105

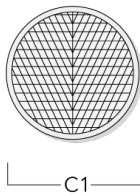

DOC220 LED

Linear spread lens

Description	Part ID	C1
IO-180-DAC/DOC220-LED	134-1381	105

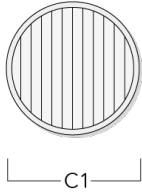

134-1210+134-1491

DOC220 LED

we-ef

Control

DALI interface

Description	Part ID	C
DALI interface	430-0013	90

WE-EF LIGHTING Pty Ltd

6/13 Downard Street, 3195 Braeside, Victoria - Phone: +61 3 8587 0444 - Fax: +61 3 8587 0499

info.australia@we-ef.com - <https://we-ef.com/aus>

Subject to technical changes and errors. - Generated on 23/11/2024