

**Safety Notice**  
The manufacturer is then discharged from liability when damage is caused by improper use or installation. If any luminaire and/or accessory is subsequently modified, the persons responsible for the modification shall be considered as manufacturer.

**Product Information / Surge Protection**  
As an option, this luminaire can also be fitted with a surge protector of Type 2-3 (at the time of order). The technical data can be found directly on the installed device. If the surge protector has been triggered by an adverse event, the luminaire is automatically disconnected from the mains. In that case, the LED on the surge protector no longer lights up.  
For comprehensive protection of the luminaire against lightning and electrical surges, primary (Type 1) and secondary (Type 2) surge arrestors must be installed into the power supply. We recommend a combination arrestor (Type 1+2+3), which is installed in the control cabinet.  
The technical planner/installer is responsible for the proper selection, sizing and installation of the surge protection modules that must be provided on site. Please note the various protection levels for Class I and II, as well as the applicable statutory provisions regarding surge protection. Installation and maintenance may only be performed by a qualified electrician.



**WE-EF LEUCHTEN**

Installation and Maintenance Instructions for Catenary mounted luminaires  
**DAS100 LED Series**



**WE-EF LEUCHTEN** Germany  
Tel +49 5194 909 0  
info.germany@we-ef.com

**WE-EF LIGHTING** Thailand  
Tel +66 2 738 9610  
info.asiapacific@we-ef.com

**WE-EF LIGHTING** Australia  
Tel +61 3 8587 0444  
info.australia@we-ef.com

**WE-EF LUMIERE** France  
Tel +33 4 74 99 14 44  
info.france@we-ef.com

**WE-EF LIGHTING** USA  
Tel +1 724 742 0030  
info.usa@we-ef.com

**WE-EF HELVETICA** Switzerland  
Tel +41 22 752 49 94  
info.switzerland@we-ef.com

DAS100\_LED\_141021 / 006-1702  
Technical specifications are subject to change.  
© WE-EF 2021

we-ef.com

**Catenary mounted luminaires**

IP66, IK07

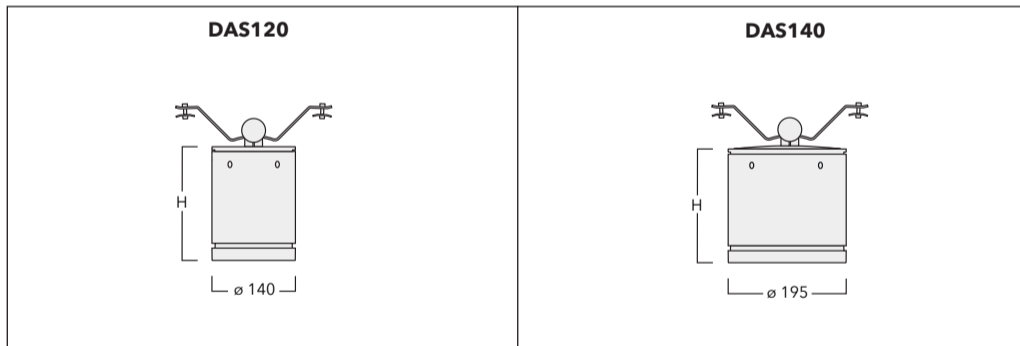

| Light source                              | Weight, Windage area   |
|---|--|
| DAS120 ..... 12 LED 24W                   | DAS120, H190..... 3,5 kg..... 0,0294 m <sup>2</sup>            |
| DAS140 ..... 24 LED 48W                   | DAS120, H250..... 3,9 kg..... 0,0376 m <sup>2</sup>            |
|   | DAS120, H300..... 4,2 kg..... 0,0446 m <sup>2</sup>            |
| Class I, II, ta = 25°C                    | DAS140, H190..... 6,6 kg..... 0,0401 m <sup>2</sup>            |
| Mounting height: ..... 3-6 m              | DAS140, H250..... 6,9 kg..... 0,0514 m <sup>2</sup>            |
| 2 x 1,5 - 2,5 mm <sup>2</sup> - 6 - 10 mm | DAS140, H300..... 7,2 kg..... 0,0611 m <sup>2</sup>            |
| 3 x 1,5 - 2,5 mm <sup>2</sup> - 9 - 14 mm |  |
| 4 x 1,5 - 2,5 mm <sup>2</sup> - 6 - 10 mm | Installation: horizontal, light output downwards               |
| 5 x 1,5 - 2,5 mm <sup>2</sup> - 9 - 16 mm | Catenary suspension, wire dia: 6-10 mm                         |
|   | Catenary suspension, wire angle adjustment (incline): max. 10° |

| Tools required                           |                           |
|--|---------------------------|
| - Torx key TX25                          | - Allen key 3 mm, 4 mm    |
| - diagonal cutting pliers                | - Open-ended spanner 8 mm |
| - Screwdriver with 4.0 mm x 1.0 mm blade |                           |

**Installation**  
The product must be installed and maintained by a suitably qualified professional in compliance with latest building/ construction and/or electrical regulations and relevant legislation.  
**Warning:** Switch off mains electrical supply prior to installing and connecting the luminaire. Do not open luminaire while mains supply is switched on.  
**Notice:** If the luminaire is modified by anybody other than the original manufacturer, then the warranty will no longer be valid and shall become the full responsibility of the modifying person/ organisation.  
Claims based on defects attributable to improper installation and/or application, and the consequences thereof, are excluded.  
In case of component failure, LED replacement due to abnormal circumstances or at end of life, replacement must be carried out by a suitably qualified and trained professional.  
In case of questions please contact our technical hotline: +61 458 933 399 (from Monday - Friday from 07.00 until 19.00 hours).

**Wiring Diagram Cable Connector**  
**WE-EF Eco Step Dim® Advanced and non dimmable luminaires**  
Class I → Phase (L1) to 1, Neutral (N) to 3 and Earthing ⊕  
Class II → Phase (L1) to 1, Neutral (N) to 3  
**WE-EF Eco Step Dim® Basic**  
Class I → Phase (L1) to 1, Control Phase (L2) to 2, Neutral (N) to 3 and Earthing ⊕  
Class II → Phase (L1) to 1, Control Phase (L2) to 2, Neutral (N) to 3  
**1-10V / DALI / WE-EF Eco Step Dim® Dynamic**  
Class I → Phase (L1) to 1, Neutral (N) to N, Control Phase (+) to 2, Control Phase (-) to 3 and Earthing ⊕  
Class II → Phase (L1) to 1, Neutral (N) to 3, Control Phase (+) to 2, Control Phase (-) to 4  
Compare the local voltage and frequency with date mentioned on the label of the luminaire.  
Screw the gland nut together, tightening to a torque of 5 Nm (fig. 5).

| Torque |               |
|--------|---------------|
| Screw  | Torque        |
| M4     | max. 2,0 Nm   |
| M5     | max. 4,0 Nm   |
| M6     | max. 6,0 Nm   |
| M8     | max. 15,0 Nm  |
| M16    | max. 100,0 Nm |

### Cable connection

Connect cable **A** in accordance with below junction box wiring diagram.

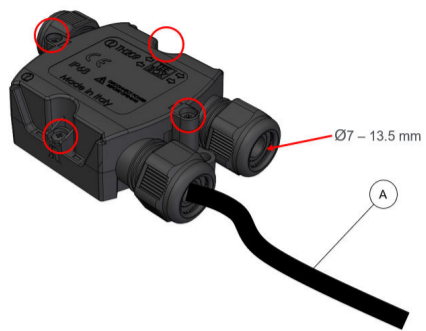
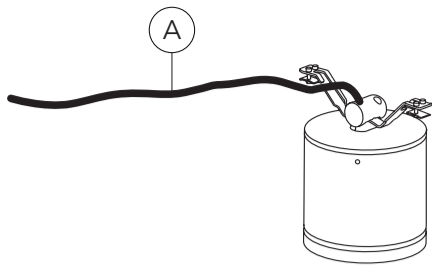

Remove junction box cover by undoing 4 screws.

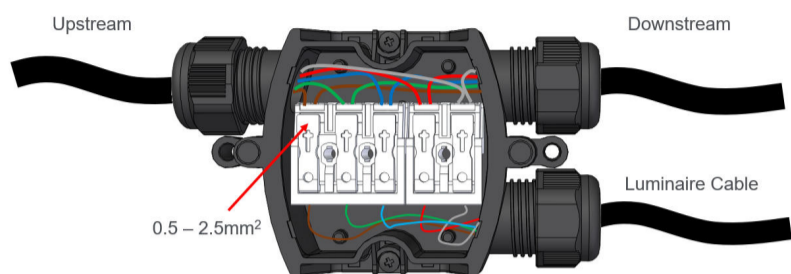

Connect upstream and downstream cables to luminaire cable as per wiring diagram. Replace junction box cover and secure junction box to catenary wire appropriately.

4) Turn wire catenary suspension clamps **C** back in position. Refer to instructions of the catenary wire producer. Tighten screws **B** back in position.

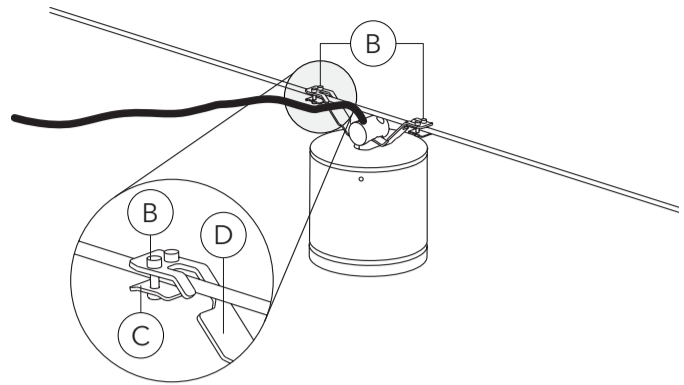

5) In case luminaire is not to be angled horizontally, wire mounting suspension can be adjusted up to 10° by release screws **F** and remove cover **G**.

Loosen screws **P**, align luminaire and retighten screws **P**. Place cover **G** back and retighten screws **F**.

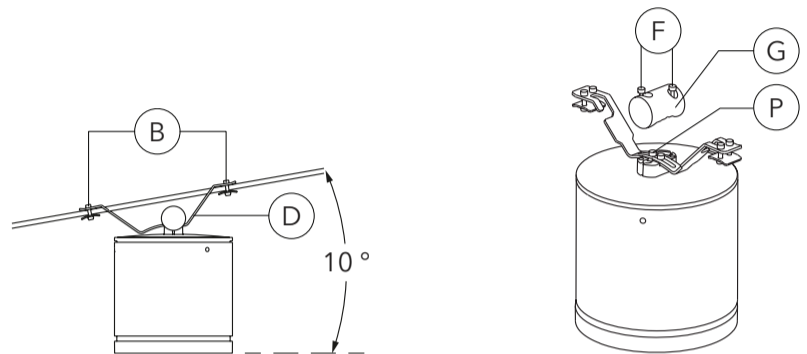

### Installation Procedure

**Luminaire is prewired and does not need to be opened for installation.**

1) Switch off the mains electrical supply **E**.

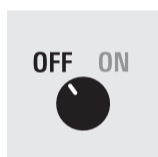

2) Loosen one of the screws **B** from the wire catenary suspension clamps **C** and release nuts.

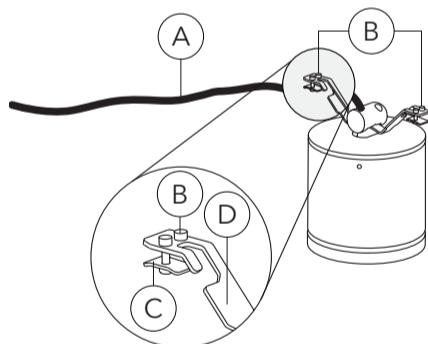

3) Turn wire catenary suspension clamps **C** out and connect luminaire with wire suspension **D** to catenary wire.

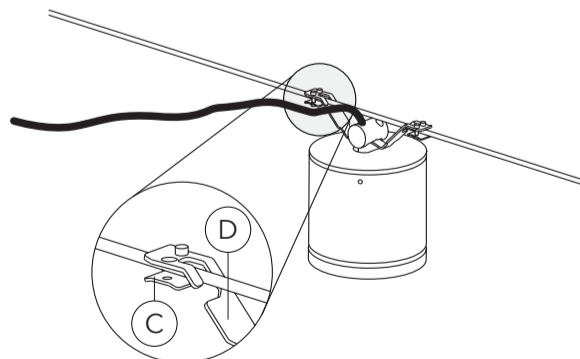

6) Maintenance is limited to regular cleaning.

**Attention:** Do not clean luminaire with a jet spray!

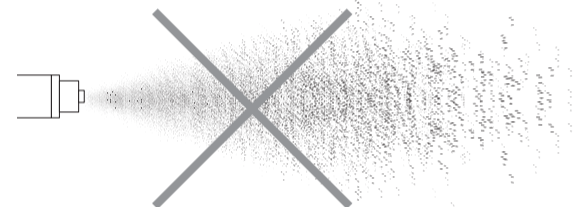

7) When using a linear lens IO-180, the light distribution must be observed during installation! (See image)

