

**we-ef**

## WE-EF LIGHTING

Installation and Maintenance  
Instructions

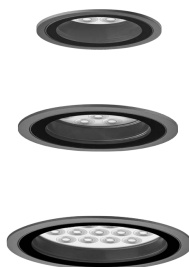

Recessed Downlight

**DOC110 LED**

**DOC120 LED**

**DOC140 LED**



### **Do not open during installation**

This product is factory-sealed.

Refer to the instructions contained in this document for details.



### **Surge Protection**

For comprehensive protection of a luminaire installation against lightning and electrical surges, it is essential to cover mains supply and data input lines at the distribution board level, by using respective primary (Type 1) and secondary (Type 2) surge arrestors in compliance with EN61643-11/IEC61643-1.

### **Warning**

Ensure that all required surge protection measures are in place and activated prior to luminaire installation. Also, disconnect luminaires before operating high-power devices such as, for example, electrical arc welders.

## Recessed Downlight

### DOC110

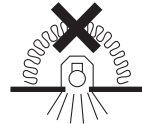
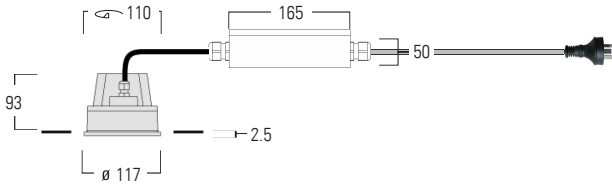

No thermal insulating material

### DOC120

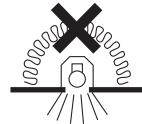
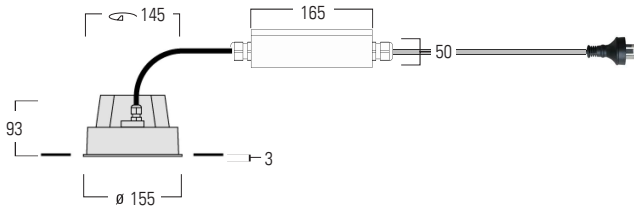

No thermal insulating material

### DOC140

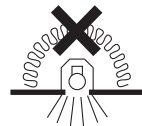
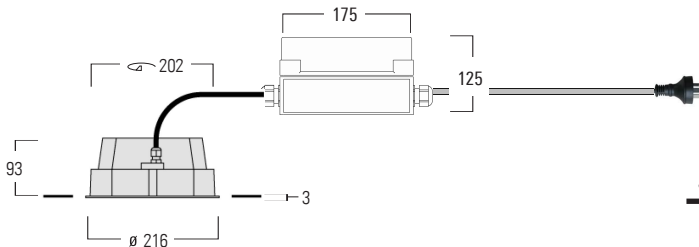

No thermal insulating material

IP66, Class I,  $t_a = 40^\circ\text{C}$ , IK07

Supplied with flex and 3 pin standard plug for ON/OFF operation.  
Supplied with five core flylead for DALI dimming operation.

### Lamps

DOC110 6 LED 12W\*

DOC120 12 LED 24W\*

DOC140 24 LED 48W\*

\* Nominal power, for latest data refer to [www.we-ef.com](http://www.we-ef.com)

## Installation dimensions

Luminaire	X	Y	Z	D
DOC110 6LED	235	min 195	max. 40	110
DOC120 12LED	235	min 195	max. 40	145
DOC140 24LED	235	min 195	max. 40	202

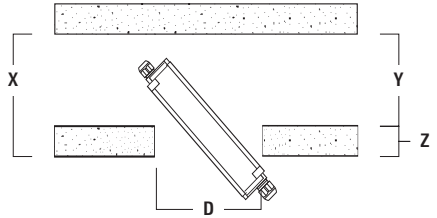

## Maintenance

Apart from cleaning the outside of the luminaire, no special maintenance work is necessary.

## DO NOT USE HIGH PRESSURE CLEANERS

High pressure cleaners can exceed the requirements of IP66.

## Installation

The product must be installed and maintained by a suitably qualified professional in compliance with latest building/construction and/or electrical regulations and relevant legislation, including installation of recessed fittings as per AS/NZS 3000.

**Warning:** Switch off and isolate the mains electrical supply prior to installing and connecting the luminaire. Luminaire is supplied as factory sealed and opening the luminaire for gear box will void the warranty.

**Notice:** If the luminaire is modified by anybody other than the original manufacturer, then the warranty will no longer be valid and shall become the full responsibility of the modifying person/organisation. Claims based on defects attributable to improper installation and/or application, and the consequences thereof, are excluded.

In case of component failure due to abnormal circumstances or at end of life, replacement must be carried out by a suitably qualified and trained professional.

If the external flexible cable or cord of this luminaire is damaged, it shall be exclusively replaced by the manufacturer or his service agent or a similar qualified person in order to avoid a hazard.

## Installation Procedure

- 1) Switch off and isolate the mains electrical supply. ⚡
- 2) Check that rating shown on luminaire label conforms with mains electrical supply.
- 3) The luminaire is supplied with a flex and plug **B** for standard operation, and a five core fly-lead for DALI/1-10V dimming. There is no requirement to open the gear box **A**.
- 4) Lead the gear box **A** through the prepared ceiling opening. As required, terminate the plug or the fly lead cable. For the dimming option the cable will be supplied with a label outlining the functionality of the core colours. Connect the cabling as per the label.
- 5) Ensure that the gear box is not located near the luminaire and complies with minimum distance requirements of recessed luminaires.
- 6) Press both clamps **C** upwards and position the luminaire **D** into ceiling opening.  
**Warning : The spring force of the clamps presents a pinch hazard**
- 7) As soon as the luminaire **D** is placed into position, the clamps **C** retain the luminaire in the ceiling.

fig. 1

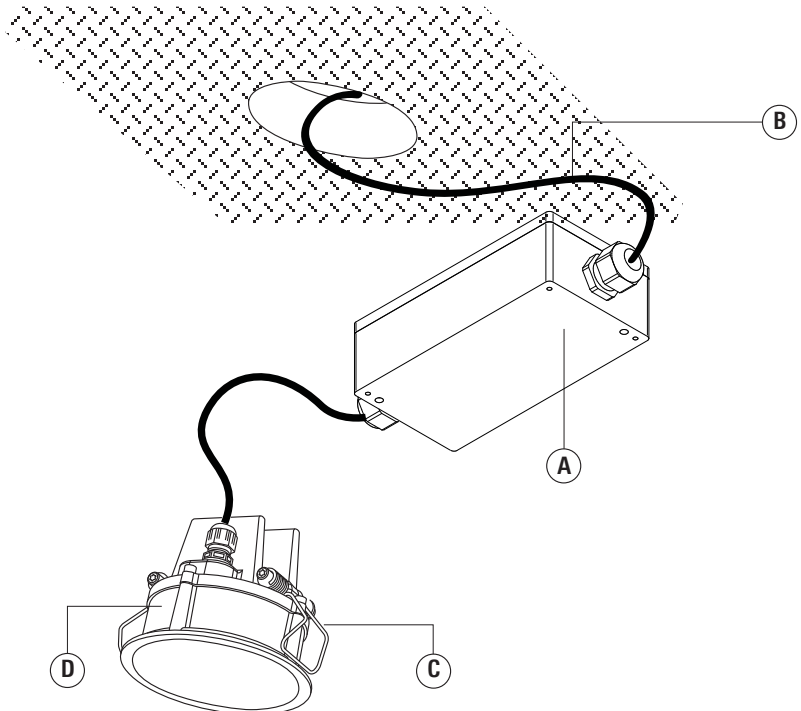
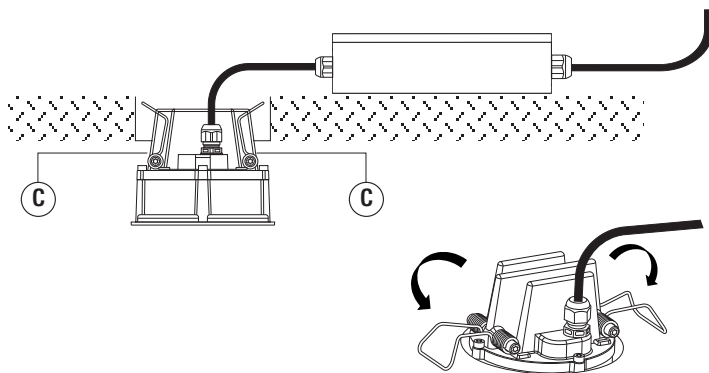

fig. 2



**WARNING – Risk of injury**

Secure the springs during installation and removal of the luminaire!

Pinch hazard present

## Installation Blockout - Proud Version

Product	ID	Type	A	B	C
DOC110	134-1639	<b>BD011-I</b>	333	232	172
DOC120	134-1748	<b>BD012-I</b>	383	272	192
DOC140	134-1763	<b>BD014-I</b>	443	324	192

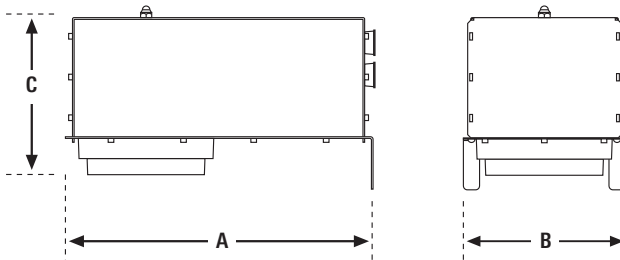
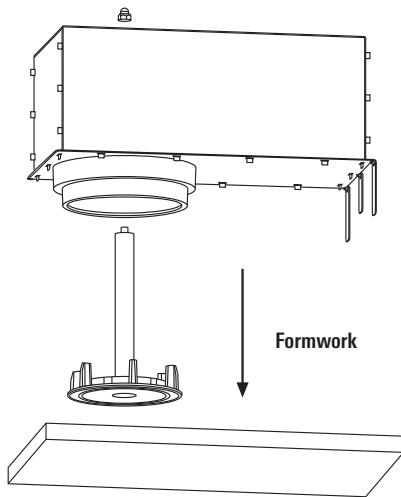

## Installation Blockout - Flush Version

Product	ID	Type	A	B	C
DOC110	134-1641	<b>BD011-III</b>	333	232	172
DOC120	134-1749	<b>BD012-III</b>	383	272	192
DOC140	134-1764	<b>BD014-III</b>	443	324	192

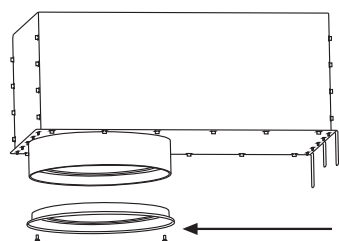
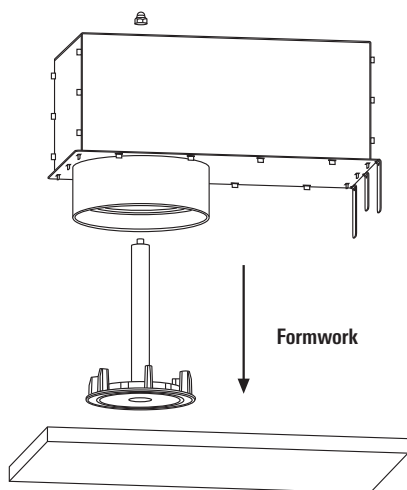

**Cover** Do not fix cover before formwork is removed!

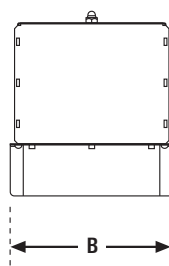
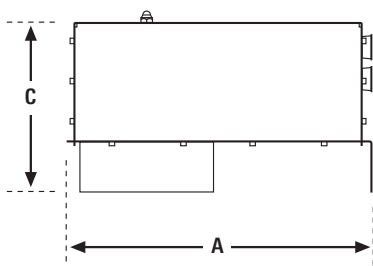

**we-ef**

[www.we-ef.com](http://www.we-ef.com)

**WE-EF LEUCHTEN**

Germany

Tel +49 5194 909 0

Fax +49 5194 909 299

[info.germany@we-ef.com](mailto:info.germany@we-ef.com)

**WE-EF LUMIERE**

France

Tel +33 4 74 99 14 44

Fax +33 4 74 99 14 40

[info.france@we-ef.com](mailto:info.france@we-ef.com)

**WE-EF HELVETICA**

Switzerland

Tel +41 22 752 49 94

Fax +41 22 752 49 74

[info.switzerland@we-ef.com](mailto:info.switzerland@we-ef.com)

**WE-EF LIGHTING**

United Kingdom

Tel +44 844 880 5346

Fax +44 844 880 5347

[info.uk@we-ef.com](mailto:info.uk@we-ef.com)

**WE-EF LIGHTING**

Thailand

Tel +66 2 738 9610

Fax +66 2 175 2174

[info.asiapacific@we-ef.com](mailto:info.asiapacific@we-ef.com)

**WE-EF LIGHTING**

Australia

Tel +61 3 8587 0444

Fax +61 3 8587 0499

[info.australia@we-ef.com](mailto:info.australia@we-ef.com)

**WE-EF LIGHTING**

United States of America

Tel +1 724 742 0030

Fax +1 724 742 0035

[info.usa@we-ef.com](mailto:info.usa@we-ef.com)



DOC100\_LED\_120419

Technical specifications are subject to change.

© WE-EF 2019

**Safety Notice**

The manufacturer is discharged from liability when damage is caused by improper use or incorrect installation.

Warranty and liability from the manufacture is void If any luminaire and/or accessory is subsequently modified.