

WE-EF LEUCHTEN
Installation and Maintenance
Instructions

Inground Luminaire
ETV100 LED



Do not open during installation

This product is factory-sealed.
Refer to the instructions contained in this document for details.



Surge Protection

This product features built-in surge protection circuitry in compliance with applicable standards.

For comprehensive protection of a luminaire installation against lightning and electrical surges, it is essential to cover mains supply and data input lines at the distribution board level, by using respective primary (Type 1) and secondary (Type 2) surge arrestors in compliance with EN61643-11/IEC61643-1.

Warning

Ensure that all required surge protection measures are in place and activated prior to luminaire installation. Also, disconnect luminaires before operating high-power devices such as, for example, electrical arc welders.

Inground Luminaire

ETV100

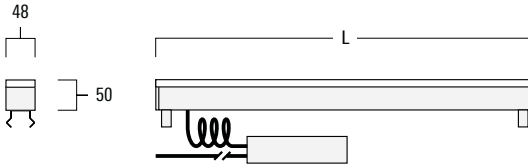

Product Dimensions:

ETV100 series	L
ETV120	627
ETV130/ETV130-CC	927
ETV140/ETV140-CC	1227

IP67, IK08. Class I. $t_a = 25^\circ\text{C}$

Mounting Accessories:

Installation breakout

	Type I B = 160 mm	Type II B = 130 mm	A
for 1 x ETV120	186-0306	186-0281	675
for 2 x ETV120	186-0307	186-0282	1304
for 3 x ETV120	186-0308	186-0283	1933
for 4 x ETV120	186-0309	186-0284	2562
for 1 x ETV130/ETV130-CC	186-0310	186-0285	975
for 2 x ETV130/ETV130-CC	186-0311	186-0286	1905
for 3 x ETV130/ETV130-CC	186-0312	186-0287	2833
for 4 x ETV130/ETV130-CC	186-0313	186-0288	3762
for 1 x ETV140/ETV140-CC	186-0314	186-0289	1275
for 2 x ETV140/ETV140-CC	186-0315	186-0290	2504
for 3 x ETV140/ETV140-CC	186-0316	186-0291	3733
for 4 x ETV140/ETV140-CC	186-0317	186-0292	4962



	d:h
[A6]	1:10
[LA10]	1:5

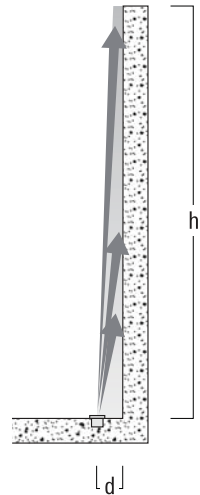

Light Source

LED

Maintenance

Apart from cleaning the product's exterior surfaces, no special maintenance work is required.

Do not use high-pressure cleaners.

In case of component failure due to abnormal circumstances or at end of life, replacement must be carried out by a suitably qualified and trained professional.

Warning: Do not open luminaire while mains supply is switched on.

For operation with Tunable White, a DALI DT8 controller is required.

Installation

The product must be installed and maintained by a suitably qualified professional in compliance with latest building/construction and/or electrical regulations and relevant legislation.

Warning: Switch off mains electrical supply prior to installing and connecting the luminaire.

Notice: If the luminaire is modified by anybody other than the original manufacturer, then the warranty will no longer be valid and shall become the full responsibility of the modifying person/organisation. Claims based on defects attributable to improper installation and/or application, and the consequences thereof, are excluded.

Attention: The luminaire is factory-sealed and does not need to be opened during installation.

The installation on site must comply with local and/or national health and safety regulations.

Blockout Installation Procedure

(during earth or masonry work)

- 1) Ensure that proper drainage is provided for the shown installation methods:
 - a) In landscape/paved areas, sand or concrete with gravel base (Fig. I).
 - b) With fully concreted installation, drainage piping must be provided (Fig. II).

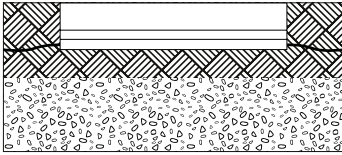

Fig. I

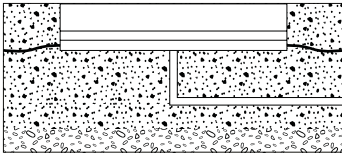
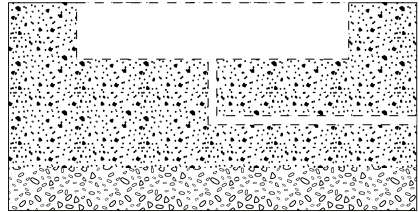

Fig. II

- 2) Ensure a suitable recess.



- 3) Test drainage (ensure water drains within 30 mins, **Warning:** warranty void if luminaire installed without appropriate drainage)

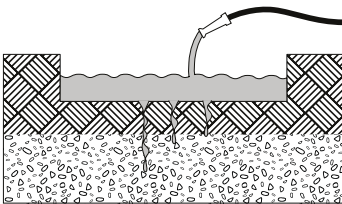

Fig. I

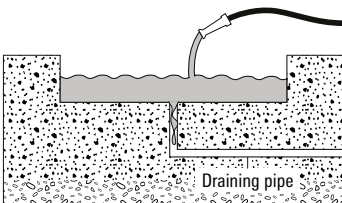
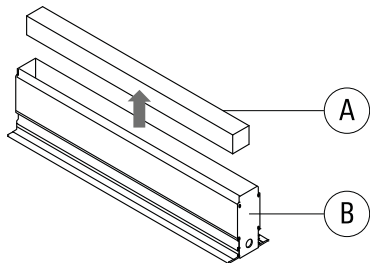
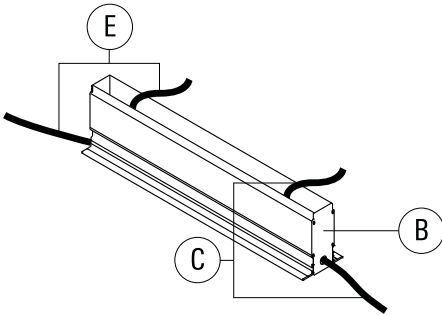

Fig. II

- 4) Remove installation cover **A** out of installation blockout **B**.



5) Feed mains supply cable C (and second cable E for through wiring) through holes inside blockout.



6) Replace blockout cover prior to luminaire installation to prevent tripping hazard/ concrete dirt getting into blockout.

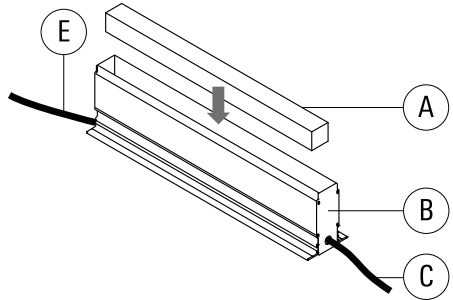

7) Blockout needs to get placed on an even, stable area. Top edge needs to be flush with surface.

Attention: If floor will be tiled or paved afterwards leave an appropriate gap. In case luminaire gets installed at a later time, blockout must get covered by installation cover A, to make sure no concrete or dirt may enter luminaire. Installation cover ensures that blockout does not get damaged during masonry works and needs to remain inside blockout until installation of luminaire.

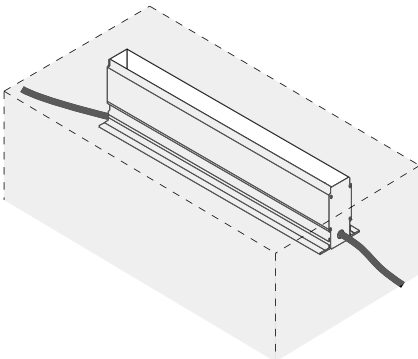

8) Framing should be installed to prevent vegetation from growing over the lens.

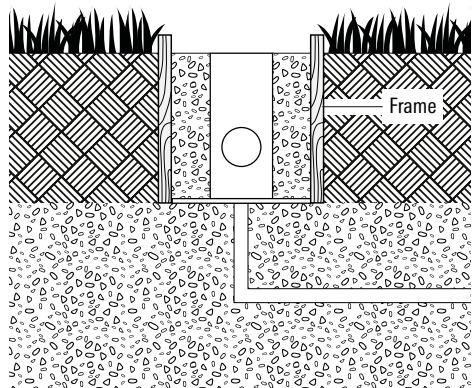

Luminaire Installation Procedure

9) Switch off and isolate mains electrical supply.

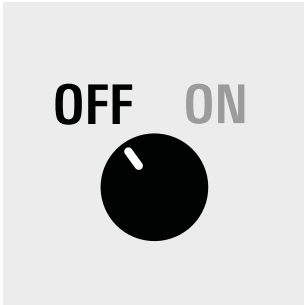

10) Check that rating shown on luminaire label conforms with mains electrical supply.

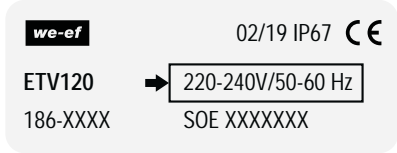

(example)

11) Luminaire is pre-wired and LED included. Opening the luminaire is not necessary.

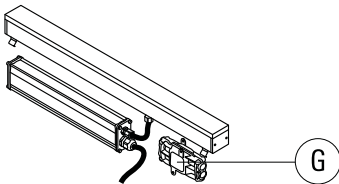

12) Remove installation cover A from blockout B.

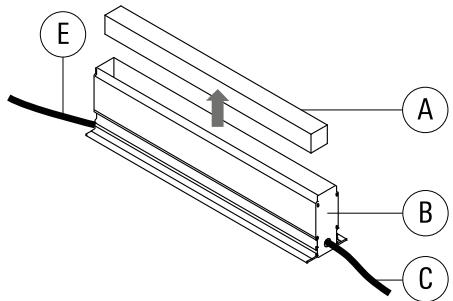



13) Take sealable junction box **G** from its bag and open it.

Warning: Be careful to not get dirt inside the gel connector when opened and connecting mains cable. Connect leads of luminaire cable **D** and mains supply cable **C** (and second cable **E** for through wiring) to respective terminals in terminal connector **F**. Mains cables **C** and **E** must not cross to ensure sealable junction box **G** can be properly closed.

a) ON/OFF (L = Phase, N = Neutral,
⊕ = Earthing)

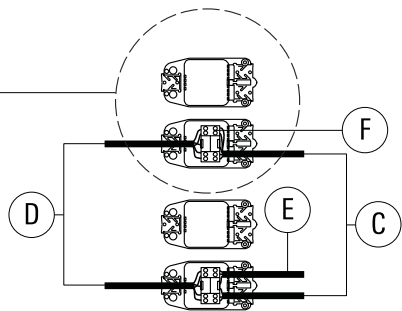
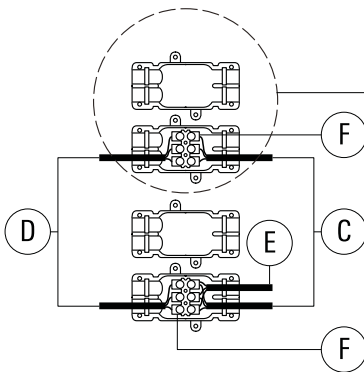
b) DALI (L = Phase, N = Neutral, ⊕ = Earthing,
DA/DA = DALI control line, DA/DA = DALI
control line)



∅ 7.5-16 mm for ON/OFF 

∅ 6.5-12 mm for DALI 

c) DMX: refer to separate wiring instruction for hybrid DMX cable.

Attention:

a) To properly terminate and seal cables with sealable junction box, refer to information packed with each sealable junction box **G**.

b) Cable sheaths must be contained within gel.

For operation with Tunable White, a DALI DT8 controller is required.

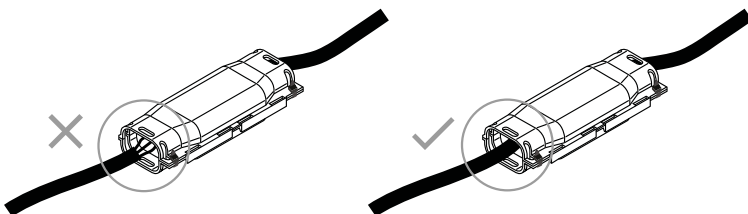

14) Place sealable junction box G and luminaire H inside blackout. Make sure no cable is squeezed.

Attention: For [LA10] and [A6], ensure correct orientation of the luminaire.

Remove label before operation of luminaire.

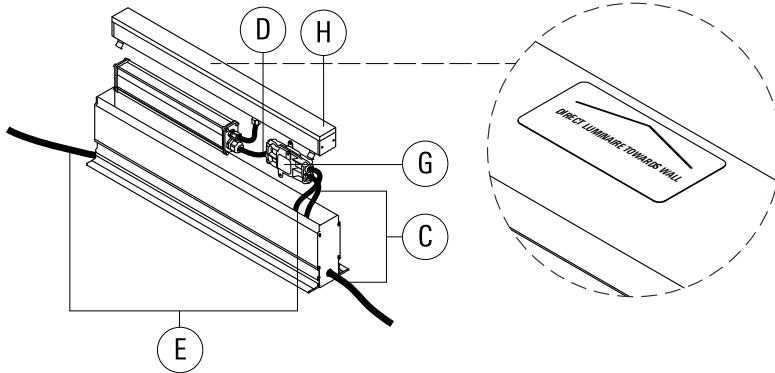

15) Install spacers I.

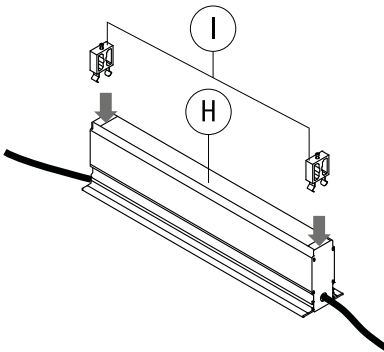

16) To remove luminaire unfasten screws K out of spacers I until you can grab their heads. Insert lever L between head of screws and spacers. Lift spacers in an upwards direction.

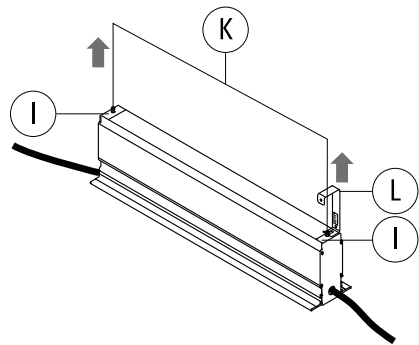

we-ef

www.we-ef.com

WE-EF LEUCHTEN

Germany

Tel +49 5194 909 0

Fax +49 5194 909 299

info.germany@we-ef.com

WE-EF LUMIERE

France

Tel +33 4 74 99 14 44

Fax +33 4 74 99 14 40

info.france@we-ef.com

WE-EF HELVETICA

Switzerland

Tel +41 22 752 49 94

Fax +41 22 752 49 74

info.switzerland@we-ef.com

WE-EF LIGHTING

Thailand

Tel +66 2 738 9610

Fax +66 2 175 2174

info.asiapacific@we-ef.com

WE-EF LIGHTING

Australia

Tel +61 3 8587 0444

Fax +61 3 8587 0499

info.australia@we-ef.com

WE-EF LIGHTING

United States of America

Tel +1 724 742 0030

Fax +1 724 742 0035

info.usa@we-ef.com



T09258W0321
ETV100_REV1_071021
© WE-EF 2021

Technical specifications are
subject to change.

WE-EF LIGHTING

Installation and Maintenance

Instructions

GEL JUNCTION BOX, c/w 6 mm T/B

185-1624

These instructions cover wiring of luminaires for different lighting control systems:

- 1) Wiring instructions for ON/OFF, 1-10V or DALI luminaires
- 2) Wiring instructions for DMX luminaires

see page 2
see page 7

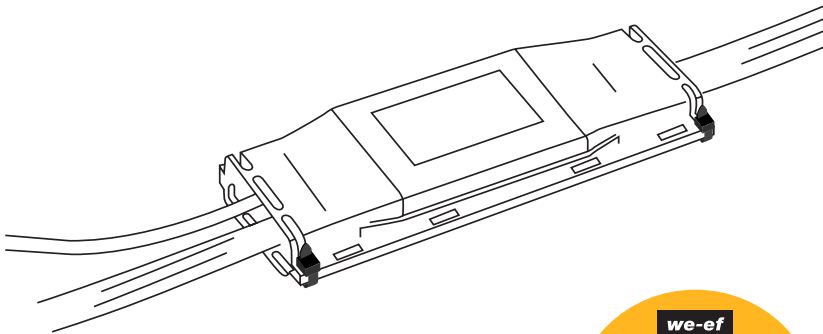

Watch a step-by-step installation guide for the IP68 gel junction box, using the QR code. Or here is a short link: <https://bit.ly/3y7dHCs>



Installation

This instruction sheet is specific to underground standard cable connections for inground up-lights supplied by WE-EF complete with pre-installation blockout. This product is designed for single use only.

It is also specific to a maximum of two x 5 core (1.5 mm² to 4 mm²) circular or flat TPS. Installations using larger and/or alternate cables are not covered by this instruction sheet, please refer to your supplier for approved instruction information.

The product must be installed and maintained by a suitably qualified professional in compliance with latest building/construction and/or electrical regulations and relevant legislation.

The installation on site must comply with local and/or national health and safety instructions.

Installation Procedure - ON/OFF, 1-10V or DALI luminaires

1) Prepare cables

a) ON/OFF

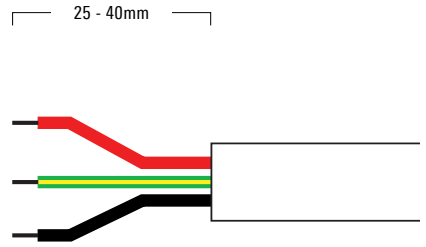
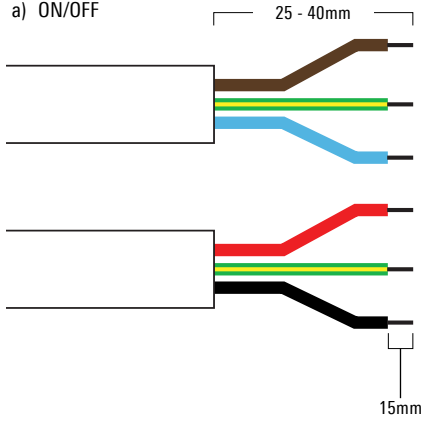

b) DALI/1-10V*

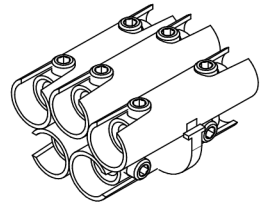
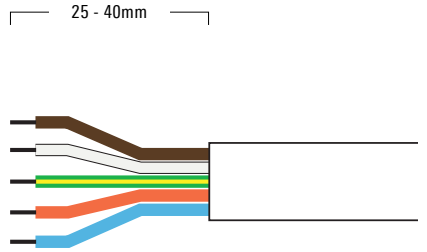
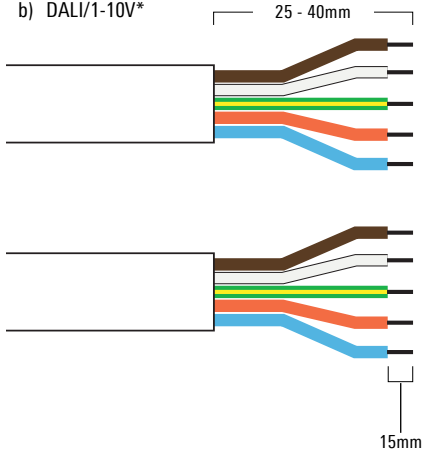

As supplied with fixture

*Confirm suitability of 1-10V connections as shown

2) Secure wires within terminal block with hex key supplied

a) ON/OFF

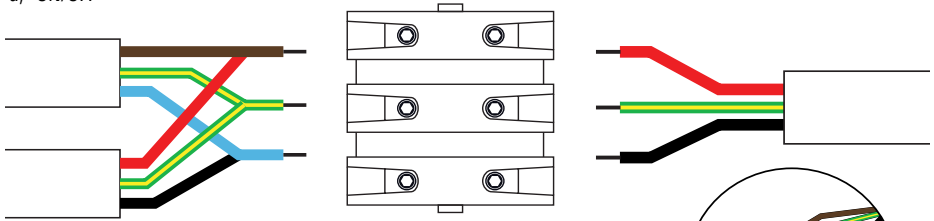

b) DALI/1-10V*

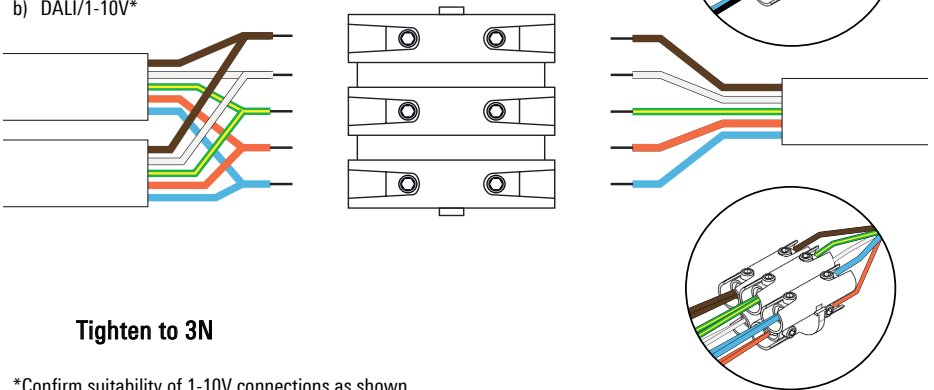

Tighten to 3N

*Confirm suitability of 1-10V connections as shown

3) Placement inside junction box

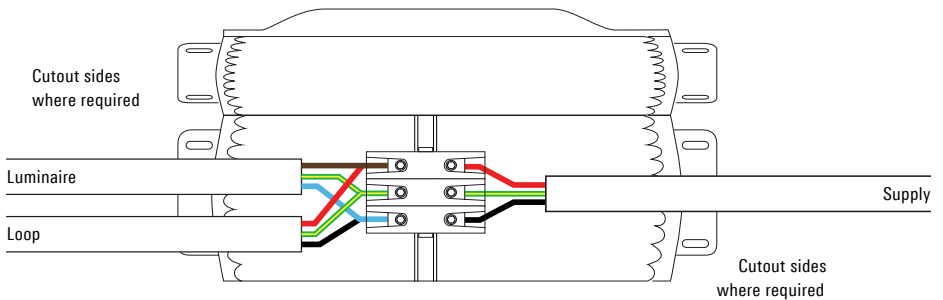

4) Click closed the junction box

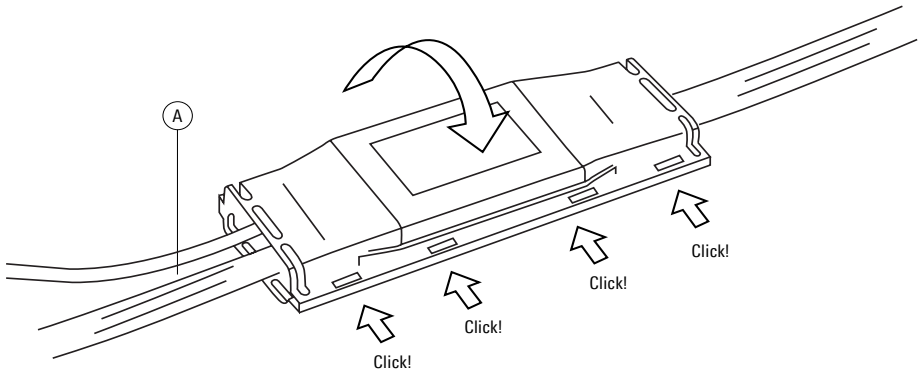

* Separate **A** – Do not lay cables on top of each other

5) Ensure gel dispersion

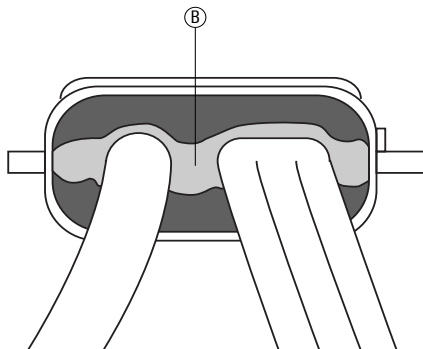

** **B** – Be sure to have gel dispersion between cables

6) Cable ties are for locking case at end

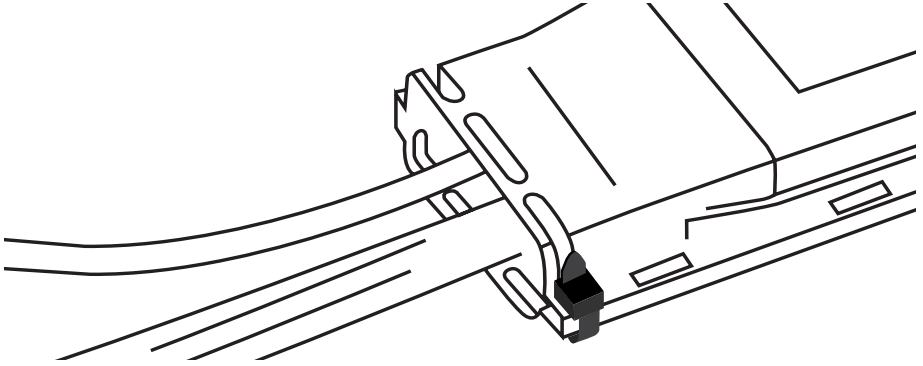

7) Power up

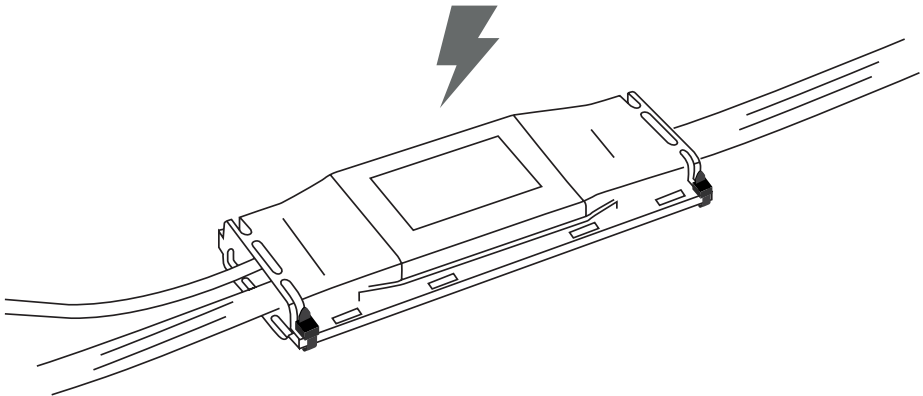

Installation Procedure - DMX luminaires

1) Scope of supply.

(illustrations are exemplary)

A: Power supply cable

B: DMX data cable

C: Junction box for DMX data cables

D: Junction box for power supply cable

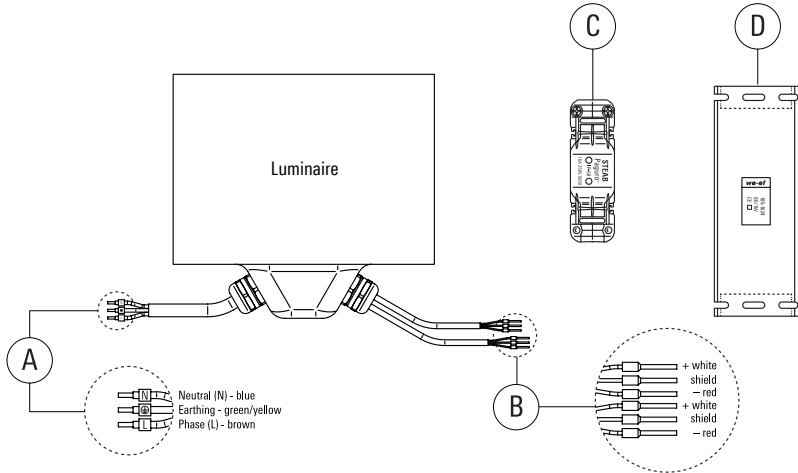

2) Overview.

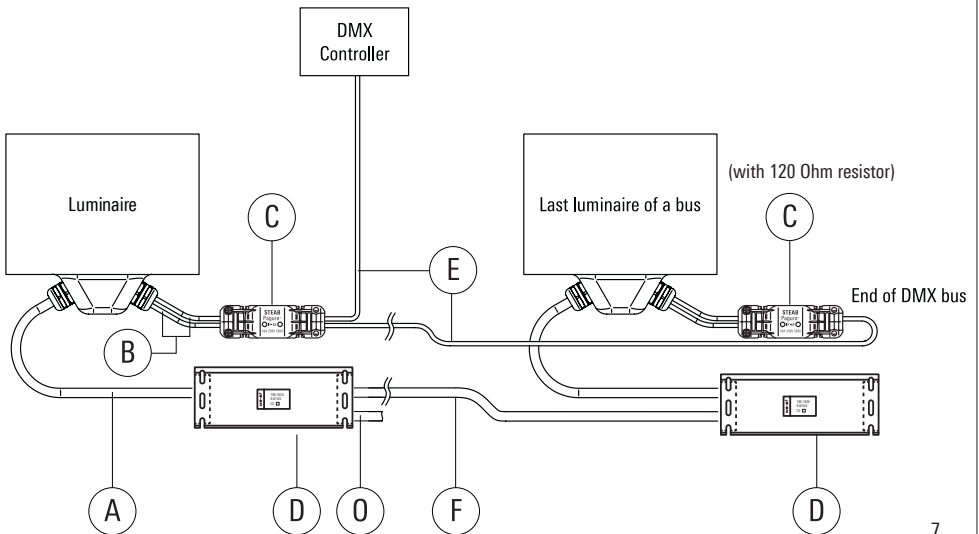

- 3) Connect luminaire's power supply cable **A** and main supply cable **O** (and second cable **F** for through wiring) to terminal block **H** within junction box **D**: L = Phase, N = Neutral, ⊕ = Earthing.
Attention: Refer to additional information packed with junction box **D** (shown wiring is exemplary only).

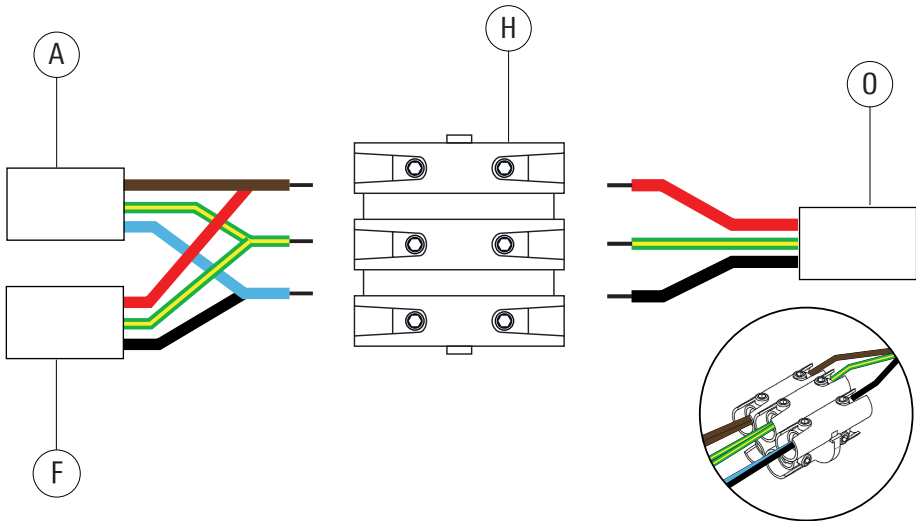

- 4) Click closed the junction box, ensure cables do not lay on top of each other

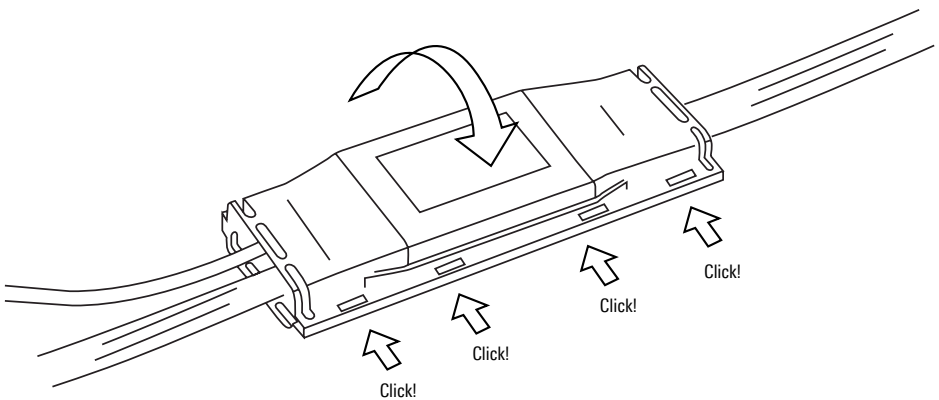

5) Ensure gel dispersion, and that individual insulation of cable cores is totally enclosed in the gel.

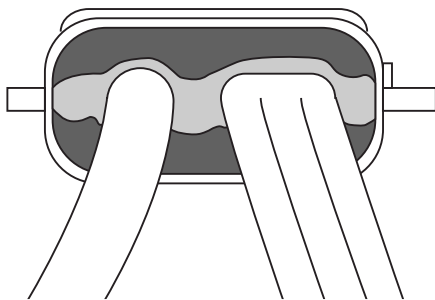

6) Tie the ends of the case closed with cable ties **K**

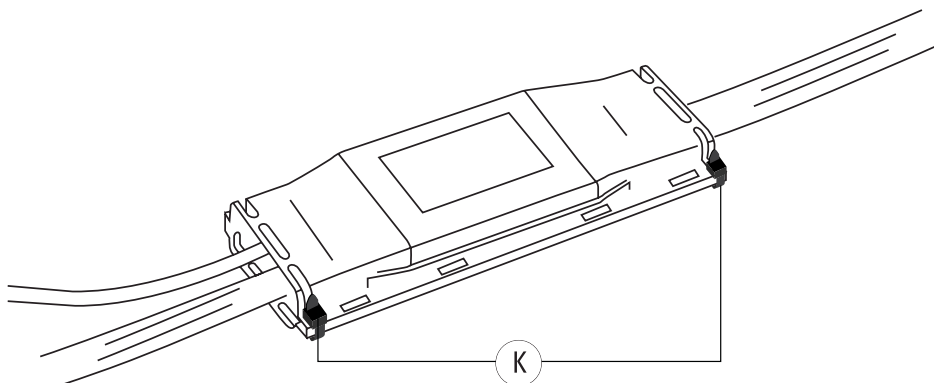

7) Connect luminaire's DMX data cables **B** and external DMX cables **E** to terminal block **I** within junction box **C**: White = DMX+, Red = DMX-, Shield. Use cord-end terminals for DMX wires.

Attention: Refer to additional information packed with junction box **C** (shown wiring is exemplary only).

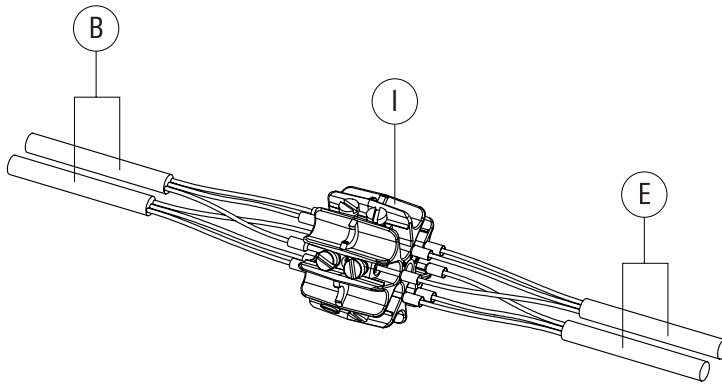

8) At the end of each DMX bus: DMX must be terminated by connecting 120 ohm resistor **G** (placed on each junction box **C** by adhesive type) between DMX+ and DMX- on terminal block **I** in junction box **C**.

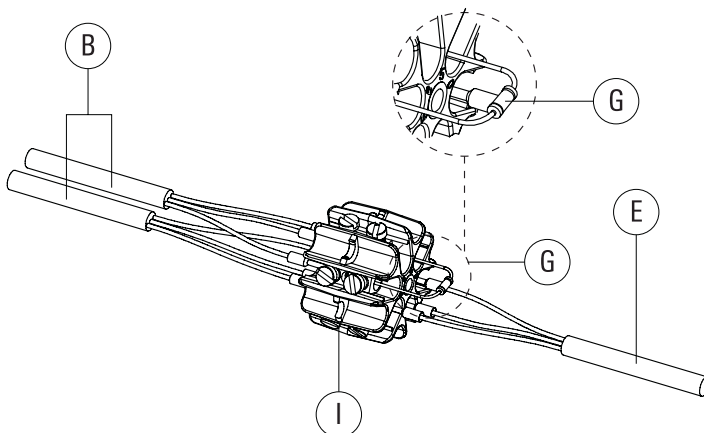

- 9) Ensure cables do not cross and that cable sheaths are contained with gel.
Tighten 4 screws.

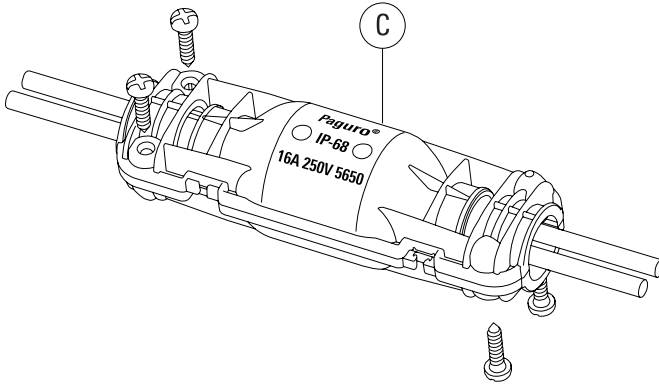

- 10) Test electrical system before burying cables.

Drainage

- 1) Ensure that proper drainage is provided for the shown installation methods:
 - a) In landscape/paved areas, sand or concrete with gravel base (Fig. I).
 - b) With fully concreted installation, drainage piping must be provided (Fig. II).

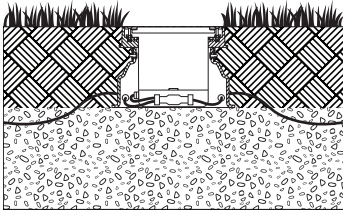

Fig. I

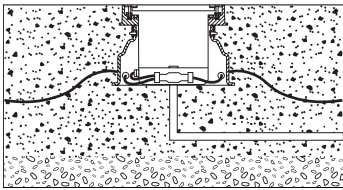
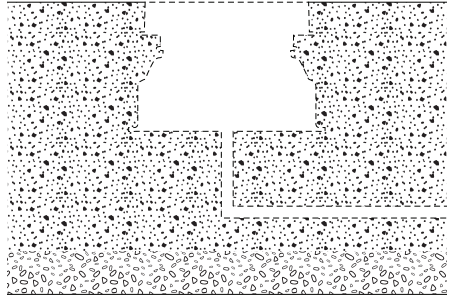

Fig. II

- 2) Ensure a suitable recess.



- 3) Test drainage (ensure water drains within 30 mins, **Warning:** warranty void if luminaire installed without appropriate drainage)

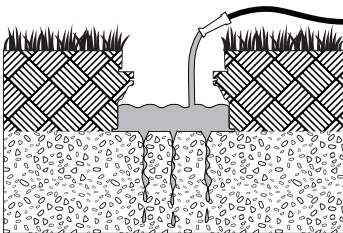

Fig. I

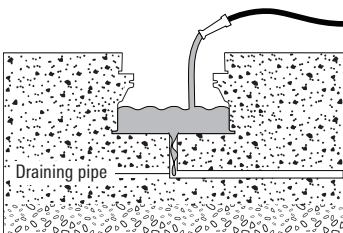
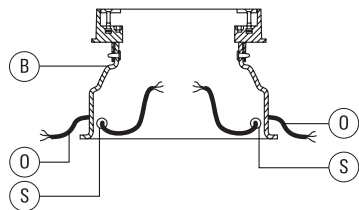

Fig. II

- 4) Select appropriate installation breakout holes **S** for mains supply cable(s) **O** and data cable(s) if necessary.



WE-EF LEUCHTEN

Germany

Tel +49 5194 909 0

Fax +49 5194 909 299

info.germany@we-ef.com

WE-EF LUMIERE

France

Tel +33 4 74 99 14 44

Fax +33 4 74 99 14 40

info.france@we-ef.com

WE-EF HELVETICA

Switzerland

Tel +41 22 752 49 94

Fax +41 22 752 49 74

info.switzerland@we-ef.com

WE-EF LIGHTING

Thailand

Tel +66 2 738 9610

Fax +66 2 175 2174

info.asiapacific@we-ef.com

WE-EF LIGHTING

Australia

Tel +61 3 8587 0444

Fax +61 3 8587 0499

info.australia@we-ef.com

WE-EF LIGHTING

United States of America

Tel +1 724 742 0030

Fax +1 724 742 0035

info.usa@we-ef.com

