



WE-EF LEUCHTEN

Installation and Maintenance Instructions

Projector

FLC210 LED

FLC220 LED

FLC230 LED

FLC240 LED

FLC260 LED

FLC210-CC LED

FLC220-CC LED

FLC230-CC LED

FLC240-CC LED

FLC260-CC LED

FLC210-TW LED

FLC220-TW LED

FLC230-TW LED

FLC240-TW LED

FLC260-TW LED



Installation tools

Mounting hardware used on this product includes fasteners with hexalobular socket heads (ISO 10664). Installation requires the use of matching tools.



Surge Protection

This product features built-in surge protection circuitry in compliance with applicable standards.

For comprehensive protection of a luminaire installation against lightning and electrical surges, it is essential to cover mains supply and data input lines at the distribution board level, by using respective primary (Type 1) and secondary (Type 2) surge arrestors in compliance with EN61643-11/IEC61643-1.

Warning

Ensure that all required surge protection measures are in place and activated prior to luminaire installation. Also, disconnect luminaires before operating high-power devices such as, for example, electrical arc welders.

Projector

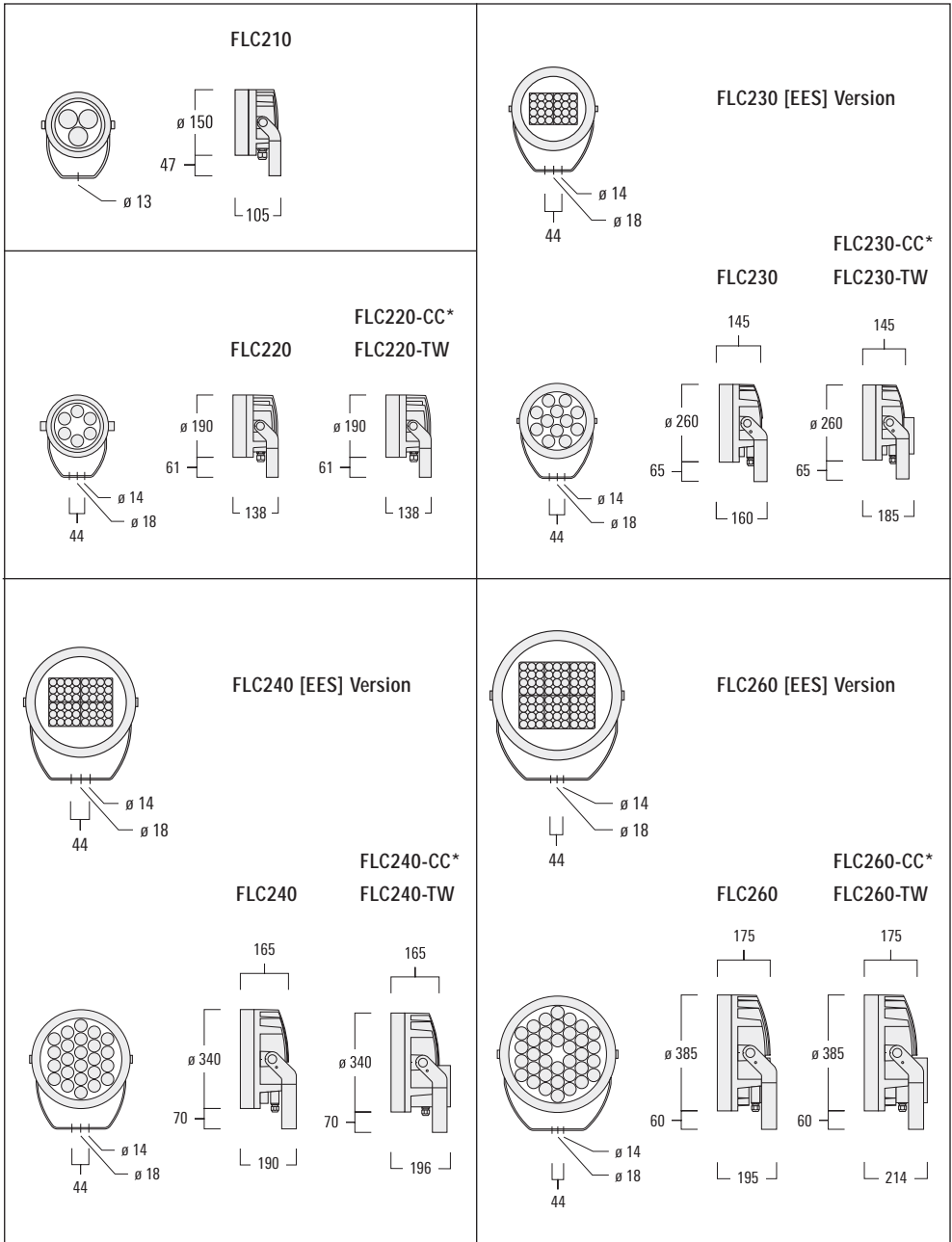

IP66, IK07, Class I, ta = 25°C

Weight	kg
for FLC210	4.0
for FLC220/FLC220-CC/FLC220-TW	4.3/4.3/4.3
for FLC230/FLC230-CC/FLC230-TW	7.6/7.7/7.7
for FLC240/FLC240-CC/FLC240-TW	12.6/13.8/13.8
for FLC260/FLC260-CC/FLC260-TW	17.5/18.0/18.5

Windage area	m ²
for FLC220	0.030
for FLC230	0.054
for FLC240	0.090
for FLC260	0.116

Tools required

- Screwdriver T-25 / T-30
- Screwdriver with blade 3 x 1

Accessories:

Wireless version*

RF for FLC220/230/240/260-CC **430-0018**

For further information refer to separate TO9267W instruction for wireless DMX.

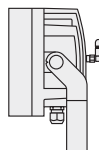

for FLC220-CC



for FLC230/240/260-CC

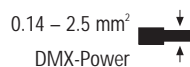

Light Source

LED

Maintenance

Apart from cleaning the product's exterior surfaces, no special maintenance work is required.

Do not use high-pressure cleaners.

In case of component failure due to abnormal circumstances or at end of life, replacement must be carried out by a suitably qualified and trained professional.

Warning: Do not open luminaire while mains supply is switched on.

For operation as colour changer the floodlights of the FLC200-CC series require a DMX control signal (DALI on request). The operation without control signal may lead to error.

For operation with Tunable White, a DALI DT8 controller is required.

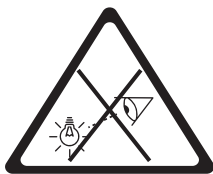

Do not stare at the operating light source.

For eye safety, the following requirement applies to luminaires with a colour temperature of 4000K in combination with light beam [EE] / [EES]:

The luminaire should be positioned so that prolonged staring into the luminaire at a distance closer than 2.8 m / 3.4 m is not expected.

Installation

The product must be installed and maintained by a suitably qualified professional in compliance with latest building/construction and/or electrical regulations and relevant legislation.

Warning: Switch off mains electrical supply prior to installing and connecting the luminaire.

Do not stare at the operating light source.

For eye safety, the following requirement applies to luminaires with a colour temperature of 4000K in combination with light beam [EE] / [EES]:

The luminaire should be positioned so that prolonged staring into the luminaire at a distance closer than 2.8 m / 3.4 m is not expected.

Notice: If the luminaire is modified by anybody other than the original manufacturer, then the warranty will no longer be valid and shall become the full responsibility of the modifying person/organisation. Claims based on defects attributable to improper installation and/or application, and the consequences thereof, are excluded.

The installation on site must comply with local and/or national health and safety regulations.

Installation Procedure

- 1) Prior to electrical connection, proceed with mechanical installation by securing stirrup **A** to optional mounting accessory or directly to a suitable surface. Aim luminaire in the desired direction.

Warning: Ensure not to damage any electric cable, water pipe or other devices while drilling holes.

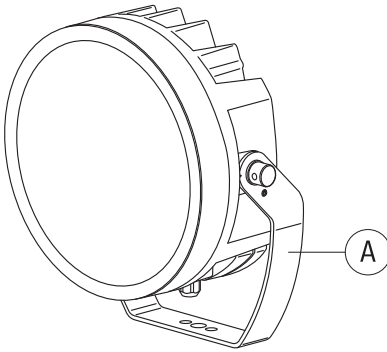

- 2) Switch off and isolate mains electrical supply.

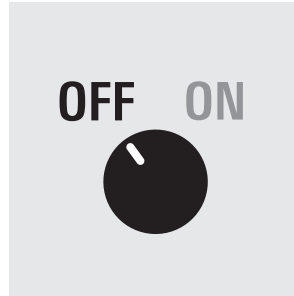

- 3) Remove gear box cover **B** by releasing screws **C** using a Torx T-25 / T-30 tool. For wireless version: Pull off connector **X** of receiver **Y**. Do not stress the cables.

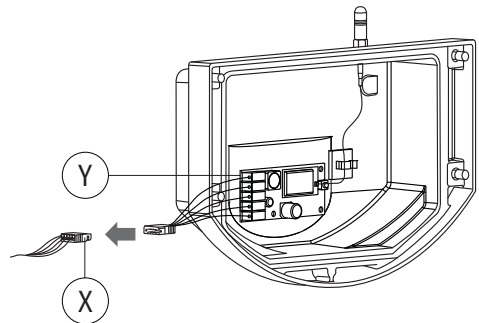
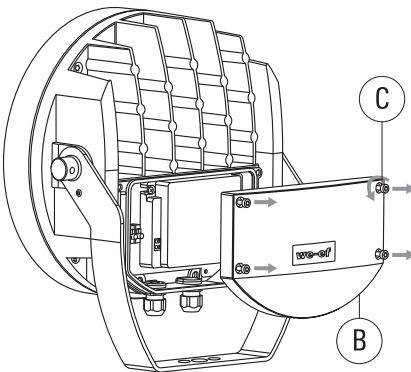

For wireless version

4) Check that rating shown on luminaire label conforms with mains electrical supply.

we-ef	11/18 IP66	CE
FLC230-LED	220-240V/50-60 Hz	
139-XXXX	SOE XXXXXXXX	
LED 3000K 12W	item no. XXX	

(example)

5) Feed mains supply cable **D** through cable gland **E**. See Fig I.

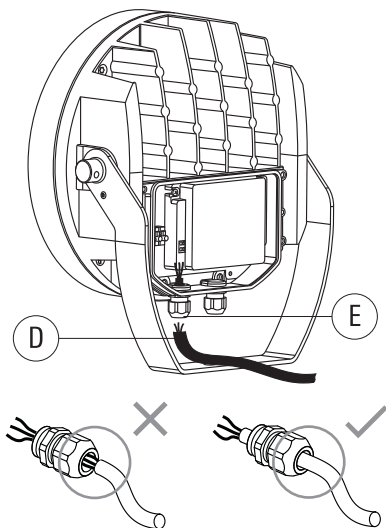
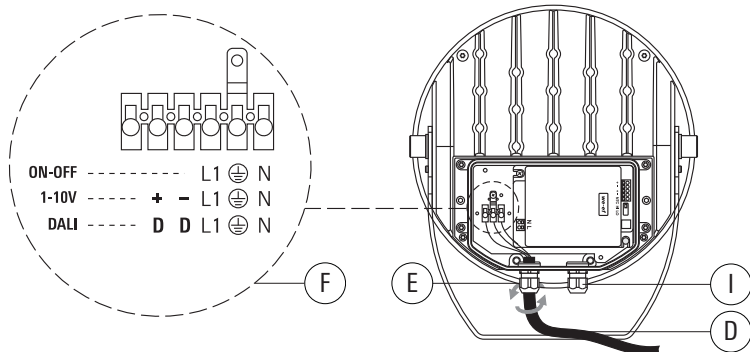

Fig I. Feed mains supply cable through cable gland

6) Connect leads of mains supply cable **D** (and second cable **I** for through wiring, if required) to respective terminals in terminal block **F**:

- a) ON/OFF or wireless version (L = Phase, N = Neutral, ⊕ = Earthing)
 - b) 1-10 V/DALI (L = Phase, N = Neutral, ⊕ = Earthing, DA/DA = DALI control line, D-/D+ = 1-10 V control line).
 - c) DMX (L = Phase, N = Neutral, ⊕ = Earthing, -/+ = DMX control line, S = Shield).
- Tighten cable gland E.

For operation with Tunable White, a DALI DT8 controller is required.



6.1) For DMX only: If through wiring (daisy-chain) for the DMX signal is required, do not use termination resistor R (not supplied) between DMX in + and DMX in – of terminal K and connect outgoing DMX wires instead. If this is the last fitting on the DMX line, use resistor R. Please change the packing ring in cable gland in order to suit DMX cable of smaller outer diameter.

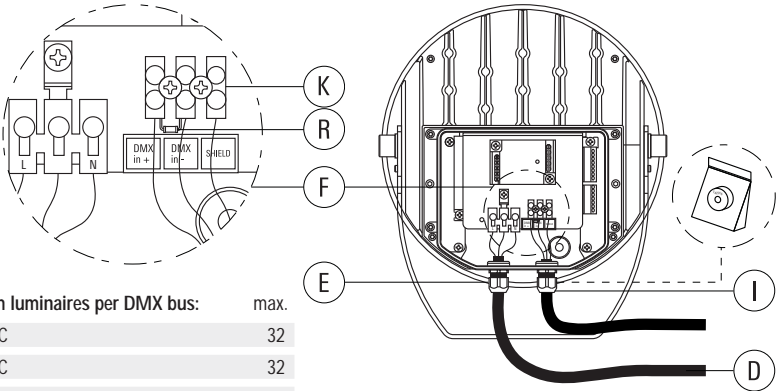

Maximum luminaires per DMX bus:	max.
FLC220-CC	32
FLC230-CC	32
FLC240-CC	16
FLC260-CC	10

If in any case more luminaires are required, the booster box has to be used.

7) Reposition gear box cover B and retighten screws C.

For wireless version: Reconnect connector X. Ensure that the connection is tightly snapped into place.

When closing the cover, do not jam any cables.

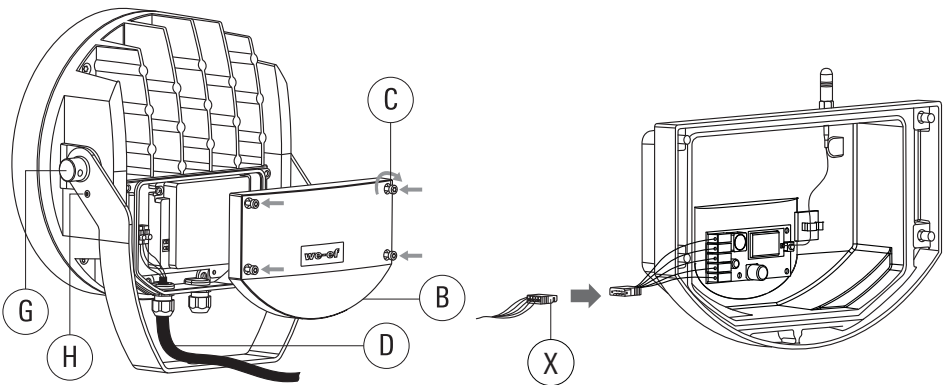

For wireless version

8) Loosen two screws **G** by insert screw driver into hole **J**. Aim luminaire (see illustration), tighten screws **G** firmly (**max. 100 Nm**). In addition, tighten screw **H** (**max. 6 Nm**) using a Torx T-30 tool to secure orientation of luminaire (not necessary for FLC220).

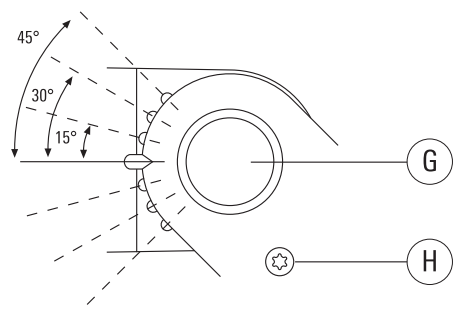
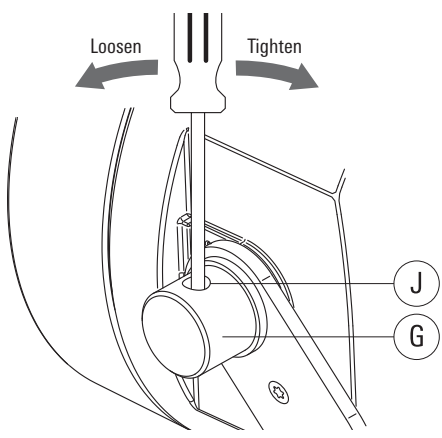

Torque

Screw	Torque
M4	max. 2.0 Nm
M5	max. 4.0 Nm
M6	max. 6.0 Nm
M8	max. 15.0 Nm
M16	max. 100.0 Nm

we-ef

www.we-ef.com

WE-EF LEUCHTEN

Germany

Tel +49 5194 909 0

Fax +49 5194 909 299

info.germany@we-ef.com

WE-EF LUMIERE

France

Tel +33 4 74 99 14 44

Fax +33 4 74 99 14 40

info.france@we-ef.com

WE-EF HELVETICA

Switzerland

Tel +41 22 752 49 94

Fax +41 22 752 49 74

info.switzerland@we-ef.com

WE-EF LIGHTING

Thailand

Tel +66 2 738 9610

Fax +66 2 175 2174

info.asiapacific@we-ef.com

WE-EF LIGHTING

Australia

Tel +61 3 8587 0444

Fax +61 3 8587 0499

info.australia@we-ef.com

WE-EF LIGHTING

United States of America

Tel +1 724 742 0030

Fax +1 724 742 0035

info.usa@we-ef.com



TO9255W0221
FLC200_REV1_060721
© WE-EF 2021

Technical specifications are
subject to change.