

Safety Notice

The manufacturer is discharged from liability when damage is caused by improper use or installation.

If any luminaire and/or accessory is subsequently modified, the persons responsible for the modification shall be considered as manufacturer.

we-ef

WE-EF LIGHTING

Installation and
Maintenance Instructions for
Post Mounted Luminaire

PFL230 LED

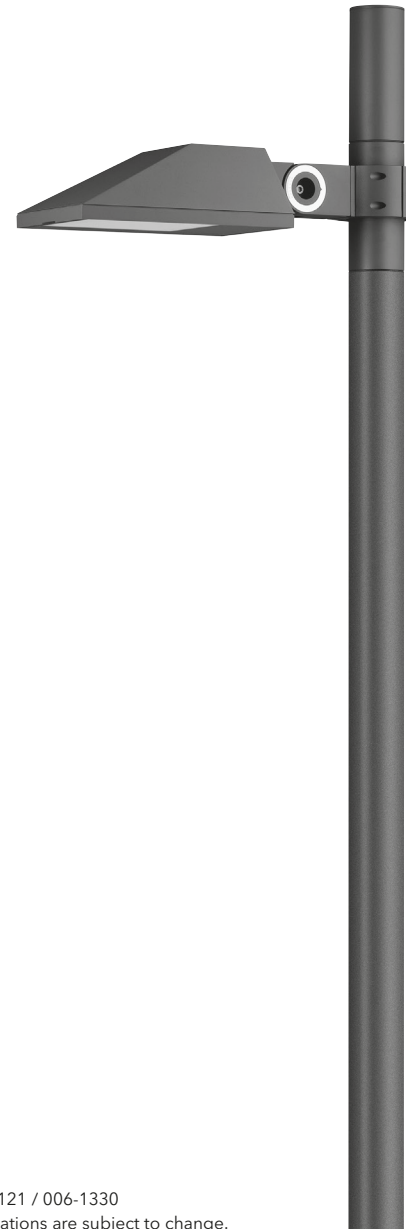

we-ef

A Fagerhult Group Company

WE-EF LIGHTING USA

Tel +1 724 742 0030

info.usa@we-ef.com

we-ef.com

PFL230 LED_241121 / 006-1330

Technical specifications are subject to change.

© WE-EF 2022

Post Mounted Luminaire

IP66, IK08

PFL230

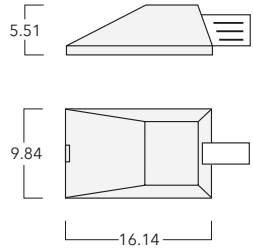

Light source

12 LED 12W / 18 LED 18W / 12 LED 24W / 18 LED 36W*

* Nominal power, for latest data refer to www.we-ef.com

Class I, II, ta = 25 °C

Mounting height 11.5 - 20 ft

Weight 21.2 lb

Windage area max. 0.452 ft²

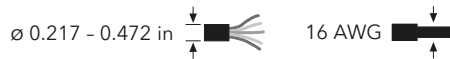

Notice

In case the luminaire is equipped with an optional available surge protector, the function can get tested if the signal LED is lit green when the supply voltage is turned on.

In case the surge protector is defective, the LED device gets automatically disconnected from the mains supply. If the signal LED is not lit, the luminaire is not functioning.

Installation

The product must be installed and maintained by a suitably qualified professional in compliance with latest building/construction and/or electrical regulations and relevant legislation.

⚡ Attention: Do not open luminaire while mains supply is switched on.

Notice: If the luminaire is modified by anybody other than the original manufacturer, then the warranty will no longer be valid and shall become the full responsibility of the modifying person/organisation. Claims based on defects attributable to improper installation and/or application, and the consequences thereof, are excluded.

In case of component failure, LED replacement due to abnormal circumstances or at end of life, replacement must be carried out by a suitably qualified and trained professional.

In case of questions please contact our technical hotline: +1 724 742 0030 (from Monday - Friday from 08.00 until 16.00 hours).

Maintenance

Apart from cleaning the product's exterior surfaces, no special maintenance work is required. Do not use high-pressure cleaners.

Protect our environment: Discard used LEDs in compliance with the most recent environmental legislation.

Installation Procedure

- 1) Switch off the mains electrical supply. ⚡

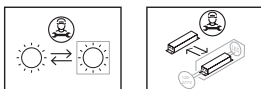
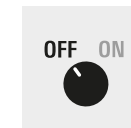

2) Loosen screws **B** and open frame **A**.

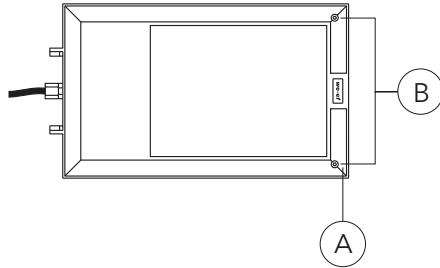

3) Unlock shutter **C** and turn down the gear-tray, disconnect plug connector **D** and remove the gear-tray.

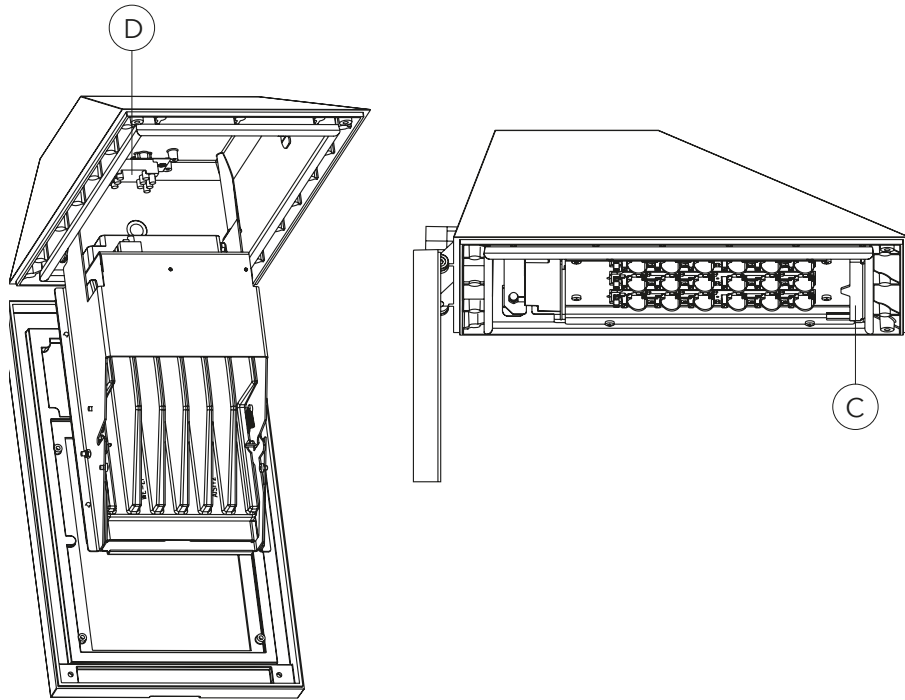

4) Cut the connecting cable **X** corresponding to the height of the pole and insert it via the bracket **E** through the cable gland **F** inside the luminaire. Connect the neutral conductor (N), phase (L1) and the Ⓧ earthing to the corresponding marked contacts of the terminal clamp **D**.

Class II: No protection earth is required. The power cable has to be double insulated according to class II.

5) Firmly tighten cable gland **F**, fasten the conduit and install the bracket **E** to the luminaire.

6) Put in gear-tray, close plug connection **D** and close the gear-tray. Make sure that the gear-tray is firmly shut.

7) Close frame **A** and firmly tighten screws **B**.

8) Feed cable through top of column, while setting luminaire in position. Secure luminaire by evenly tightening the six hexagon socket screws **G**.

