



**WE-EF LEUCHTEN**  
Installation and Maintenance  
Instructions

Wall Luminaires Surface Mounted  
PLS420 LED  
PLS430 LED



**Do not open during installation**

This product is factory-sealed.  
Refer to the instructions contained in this document for details.



**Surge Protection**

This product features built-in surge protection circuitry in compliance with applicable standards.

For comprehensive protection of a luminaire installation against lightning and electrical surges, it is essential to cover mains supply and data input lines at the distribution board level, by using respective primary (Type 1) and secondary (Type 2) surge arrestors in compliance with EN61643-11/IEC61643-1.

**Warning**

Ensure that all required surge protection measures are in place and activated prior to luminaire installation. Also, disconnect luminaires before operating high-power devices such as, for example, electrical arc welders.

## Wall Luminaires Surface Mounted

PLS420

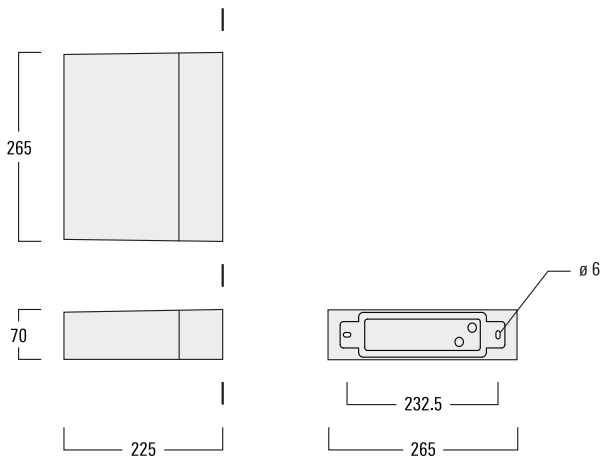

PLS430

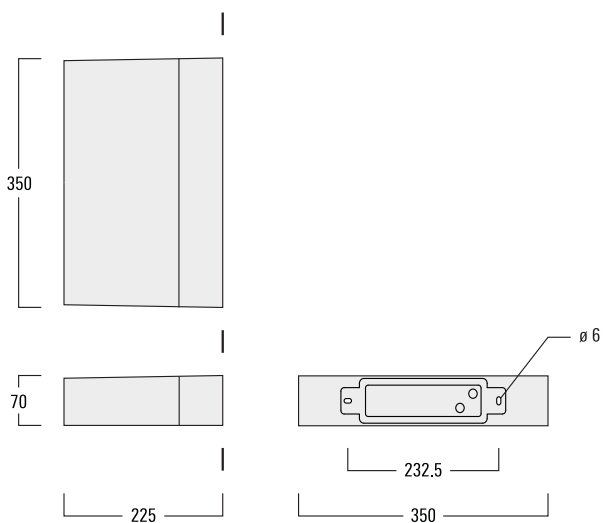

IP66, IK08. Class I,  $t_a = 40^\circ\text{C}$

## Light Source

LED

## Maintenance

Apart from cleaning the product's exterior surfaces, no special maintenance work is required.

Do not use high-pressure cleaners.

In case of component failure due to abnormal circumstances or at end of life, replacement must be carried out by a suitably qualified and trained professional.

**Warning:** Do not open luminaire while mains supply is switched on.

## **Installation**

The product must be installed and maintained by a suitably qualified professional in compliance with latest building/construction and/or electrical regulations and relevant legislation.

**Warning:** Switch off mains electrical supply prior to installing and connecting the luminaire.

**Notice:** If the luminaire is modified by anybody other than the original manufacturer, then the warranty will no longer be valid and shall become the full responsibility of the modifying person/organisation. Claims based on defects attributable to improper installation and/or application, and the consequences thereof, are excluded.

The installation on site must comply with local and/or national health and safety regulations.

## Installation Procedure

1) Switch off mains electrical supply.

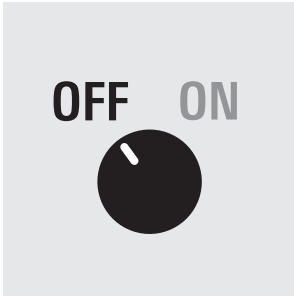

2a) ON-OFF version

Remove wall flange **A** from luminaire housing **B** by loosening screws **C**. Pull off terminal connector **D**.

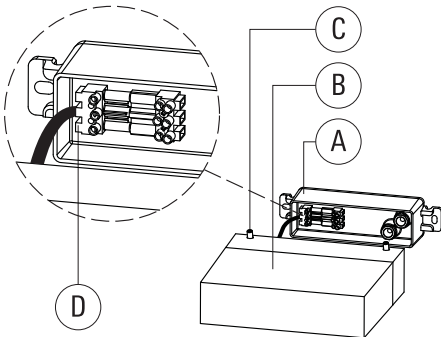

2b) Dimming versions (1-10 V/DALI)

Remove wall flange **A** from luminaire housing **B** by loosening screws **C**. Pull off terminal connector **D**. Remove terminal cover **L**.

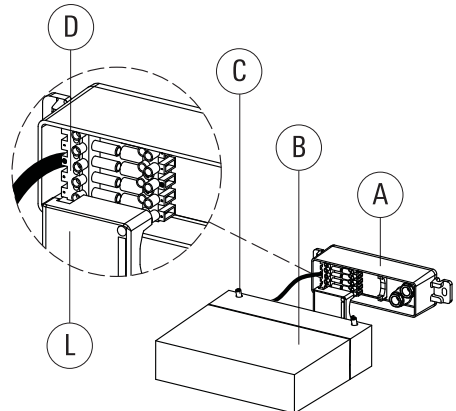

- 3) Check that rating shown on luminaire label conforms with mains electrical supply.

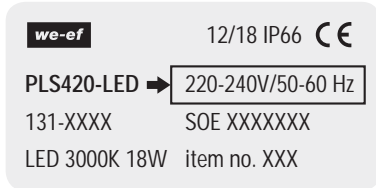

(example)

- 5) Feed mains supply cable H (and second cable I for through wiring, if required) through pressure screw(s) J, while setting wall flange A in position.

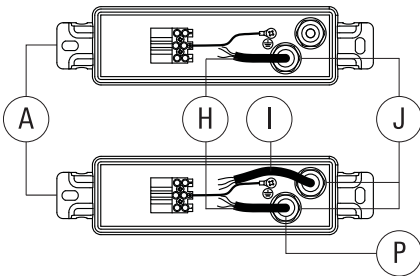

The pre-installed packing ring P is suitable for cable diameters 7 to 9.5 mm and TPS cable to suit 1.5 - 2.5mm.



For larger cable diameters (9 to 12 mm) use the auxiliary packing ring supplied.

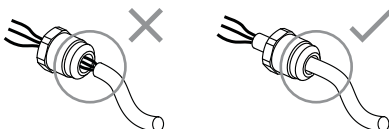

- 4) Determine position for fixing screws E. Drill relevant holes F and insert nylon plugs G (not supplied by WE-EF).

**Warning:** Ensure not to damage any electrical cable, water pipe or other items drilling holes.

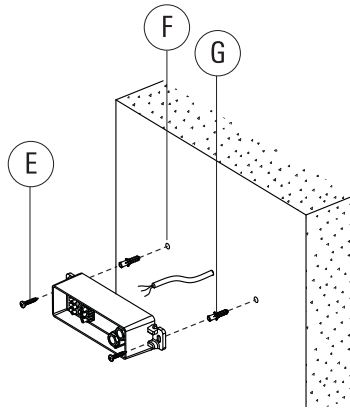

- 6) To fix wall flange A, insert and tighten screws E. The orientation of wall flange A determines orientation of luminaire (up or down)

Uplight

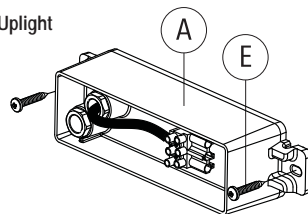

Downlight

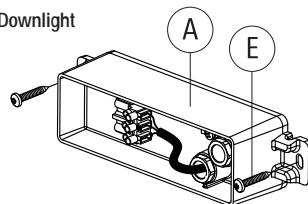

7) Connect leads of mains supply cable H (and second cable I for through wiring, if required) to respective terminals of socket K:

a) ON/OFF (L = Phase, N = Neutral, ⊕ = Earthing)

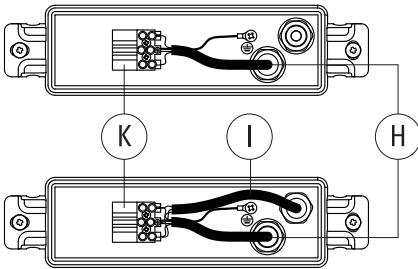

b) 1-10 V/DALI (L = Phase, N = Neutral, ⊕ = Earthing, DA/DA = DALI control line, D-/D+ = 1-10 V control line).

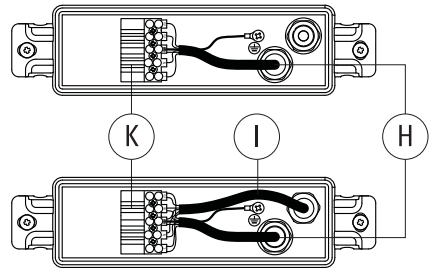

8a) ON-OFF version

Position luminaire housing B over wall flange A and reconnect terminal connector D.

Tighten 4 screws C both on top and bottom.

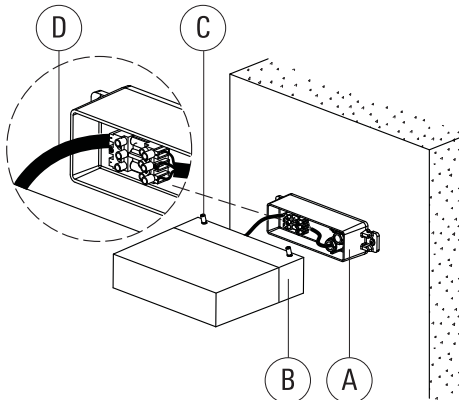

8b) Dimming versions (1-10 V/DALI)

Position luminaire housing B over wall flange A and reconnect terminal connector D.

Return terminal cover L. Tighten 4 screws C both on top and bottom.

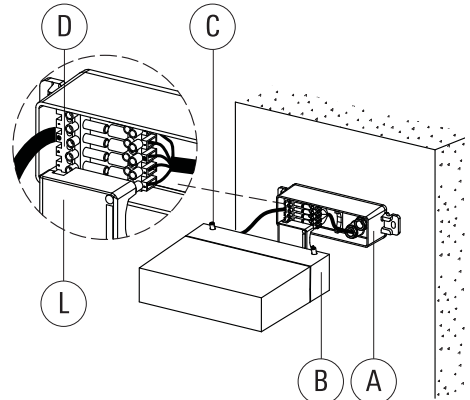

**we-ef**

www.we-ef.com

**WE-EF LEUCHTEN**

Germany

Tel +49 5194 909 0

Fax +49 5194 909 299

info.germany@we-ef.com

**WE-EF LUMIERE**

France

Tel +33 4 74 99 14 44

Fax +33 4 74 99 14 40

info.france@we-ef.com

**WE-EF HELVETICA**

Switzerland

Tel +41 22 752 49 94

Fax +41 22 752 49 74

info.switzerland@we-ef.com

**WE-EF LIGHTING**

United Kingdom

Tel +44 844 880 5346

Fax +44 844 880 5347

info.uk@we-ef.com

**WE-EF LIGHTING**

Thailand

Tel +66 2 738 9610

Fax +66 2 175 2174

info.asiapacific@we-ef.com

**WE-EF LIGHTING**

Australia

Tel +61 3 8587 0444

Fax +61 3 8587 0499

info.australia@we-ef.com

**WE-EF LIGHTING**

United States of America

Tel +1 724 742 0030

Fax +1 724 742 0035

info.usa@we-ef.com



T09251W0419 © WE-EF 2019

Technical specifications are  
subject to change.