



WE-EF LEUCHTEN

Installation and Maintenance
Instructions

Post Mounted Luminaire

RFL530-SE LED

RFL540-SE LED



Do not open during installation

This product is factory-sealed.
Refer to the instructions contained in this
document for details.



Surge Protection

This product features built-in surge protection circuitry in compliance
with applicable standards.

For comprehensive protection of a luminaire installation against lightning
and electrical surges, it is essential to cover mains supply and data input
lines at the distribution board level, by using respective primary (Type 1)
and secondary (Type 2) surge arrestors in compliance with EN61643-11/
IEC61643-1.

Warning

Ensure that all required surge protection measures are in place and
activated prior to luminaire installation. Also, disconnect luminaires
before operating high-power devices such as, for example, electrical
arc welders.

Post Mounted Luminaire

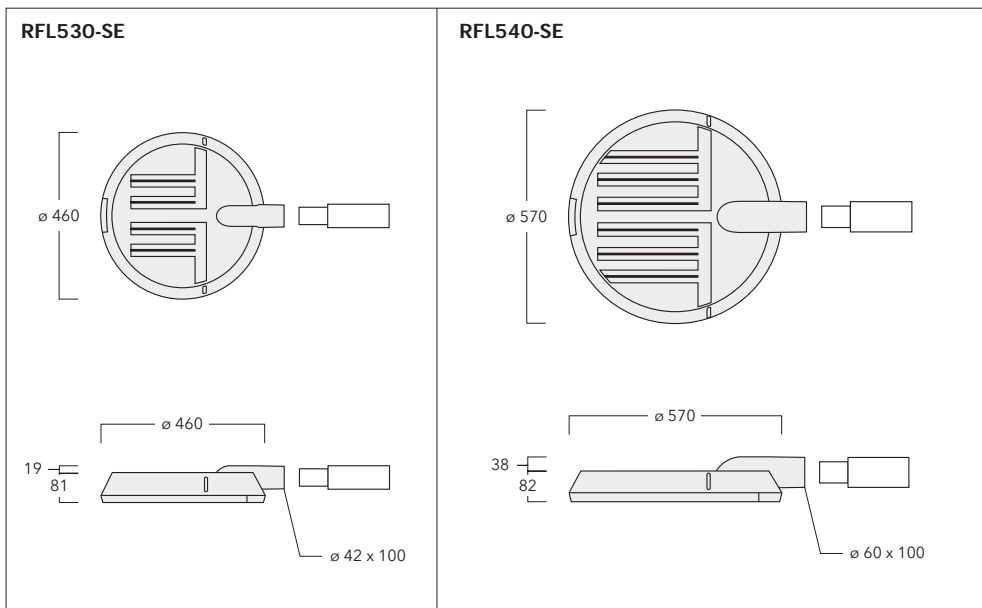

IP66, IK07, Class I, $t_a = 25^\circ\text{C}$

Mounting height

m

for RFL530-SE/RFL540-SE

3 - 6

Weight

kg

for RFL530-SE

9.3

for RFL540-SE

15.0

Windage area

m^2

RFL530-SE

0.166

RFL540-SE

0.255

Installation: horizontal, light output downwards,

Suitable for spigot diameter $D = 60 \times 80 \text{ mm}$ or $D = 76 \times 80 \text{ mm}$

Upper pole offset $D1$ max. 102 mm

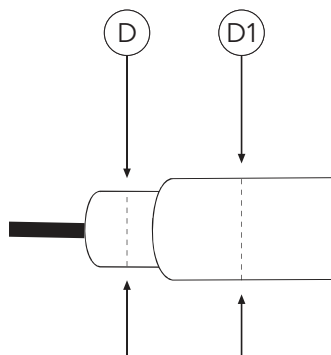

Light Source

LED

Maintenance

Apart from cleaning the product's exterior surfaces, no special maintenance work is required.

Do not use high-pressure cleaners.

In case of component failure due to abnormal circumstances or at end of life, replacement must be carried out by a suitably qualified and trained professional.

Warning: Do not open luminaire while mains supply is switched on.

For **Wild-Light applications**, refer to separate TO9281W instruction for Wild-Light motion box.

Installation

The product must be installed and maintained by a suitably qualified professional in compliance with latest building/construction and/or electrical regulations and relevant legislation.

The supply cable must be installed inside the pole and not be exposed to the outside environment.

Warning: Switch off mains electrical supply prior to installing and connecting the luminaire.

Notice: If the luminaire is modified by anybody other than the original manufacturer, then the warranty will no longer be valid and shall become the full responsibility of the modifying person/organisation. Claims based on defects attributable to improper installation and/or application, and the consequences thereof, are excluded.

Attention: The luminaire is factory-sealed and does not need to be opened during installation.

The installation on site must comply with local and/or national health and safety regulations.

Installation Procedure

- 1) Switch off mains electrical supply.
- 2) Check that rating shown on luminaire label conforms with mains electrical supply.
- 3) Feed mains luminaire cable **A** into outreach bracket **C**, while setting luminaire assembly in position. Tighten screw **B**.
- 4) Connect mains luminaire cable **A** lead and mains supply cable **E** leads to the provided separate connector as shown in fig. 1 to fig. 4, while setting luminaire-bracket assembly in position
1 = Phase (L), N = Neutral (N), 2 = DA+, 3 = DA-, ⊕ = Earthing (PE)
- 5) Trim mains supply cable **E** to the desired length and connect leads to their respective terminals at the base of pole.

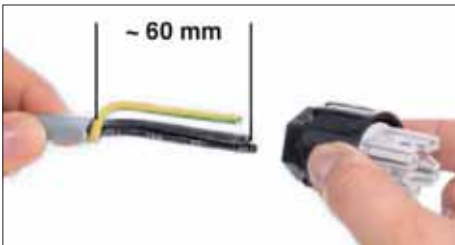

fig. 1



fig. 2



fig. 3



fig. 4

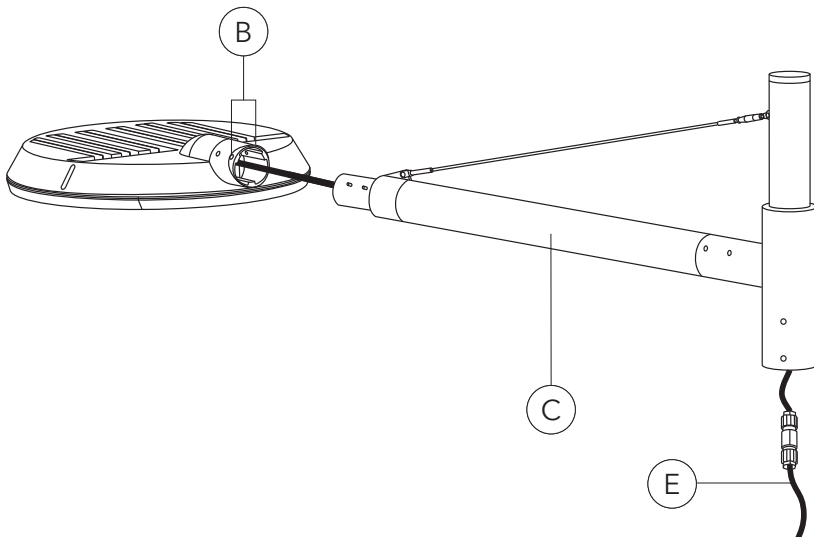
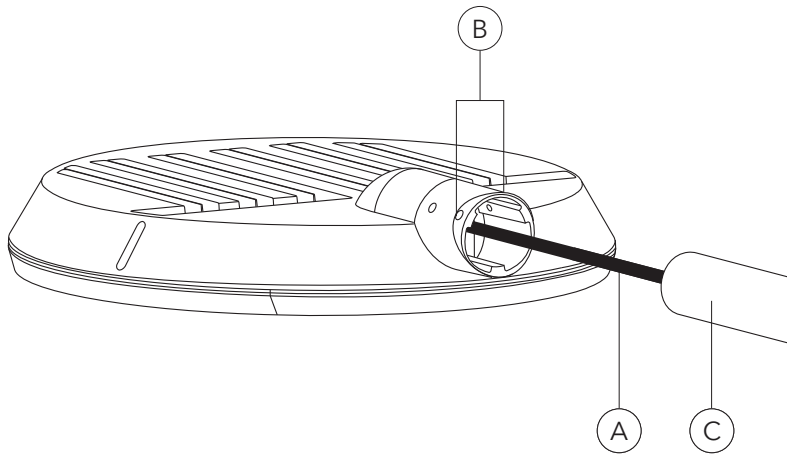

we-ef

www.we-ef.com

WE-EF LEUCHTEN

Germany

Tel +49 5194 909 0

Fax +49 5194 909 299

info.germany@we-ef.com

WE-EF LUMIERE

France

Tel +33 4 74 99 14 44

Fax +33 4 74 99 14 40

info.france@we-ef.com

WE-EF SWITZERLAND

Switzerland

Tel +41 22 752 49 94

Fax +41 22 752 49 74

info.switzerland@we-ef.com

WE-EF LIGHTING

Thailand

Tel +66 2 738 9610

Fax +66 2 175 2174

info.asiapacific@we-ef.com

WE-EF LIGHTING

Australia

Tel +61 3 8587 0444

Fax +61 3 8587 0499

info.australia@we-ef.com

WE-EF LIGHTING

United States of America

Tel +1 724 742 0030

Fax +1 724 742 0035

info.usa@we-ef.com

TO9185W0724 © WE-EF 2024

Technical specifications are
subject to change.

WE-EF LEUCHTEN

Installation and Maintenance
Instructions

Post Mounted Luminaires

Wild-Light motion box



Box motion for Wild-Light

SLC box motion

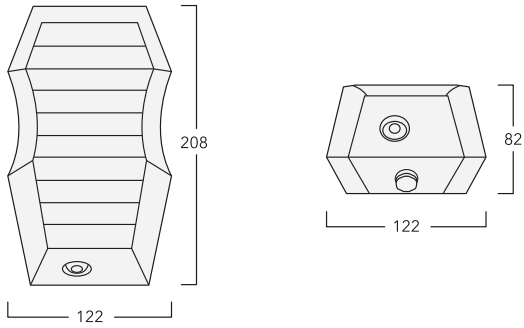

Light Source

LED

Maintenance

Apart from cleaning the product's exterior surfaces, no special maintenance work is required.

Do not use high-pressure cleaners.

In case of component failure due to abnormal circumstances or at end of life, replacement must be carried out by a suitably qualified and trained professional.

Warning: Do not open product while mains supply is switched on.

Installation

The product must be installed and maintained by a suitably qualified professional in compliance with latest building/construction and/or electrical regulations and relevant legislation.

Warning: Switch off mains electrical supply prior to installing and connecting the product.

Notice: If the product is modified by anybody other than the original manufacturer, then the warranty will no longer be valid and shall become the full responsibility of the modifying person/organisation. Claims based on defects attributable to improper installation and/or application, and the consequences thereof, are excluded.

Attention: The product is factory-sealed and does not need to be opened during installation.

The installation on site must comply with local and/or national health and safety regulations.

Installation Procedure for Wild-Light

- 1) Identify the right location for the motion box on the pole. Note that the sensor has to be directed downwards and be installed in a height between 0 and 6 m*.

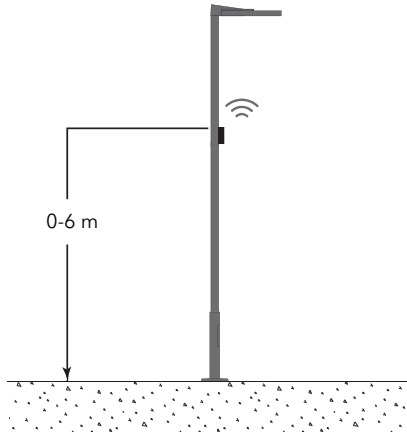

* Separate box for 6-12 m available on request

- 2) Prepare a cable entry hole in the pole. Avoid sharp edges that could damage the cable.

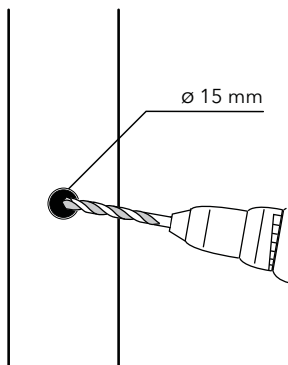

3) Insert the cable of the motion box in the pole through the cable entry hole.

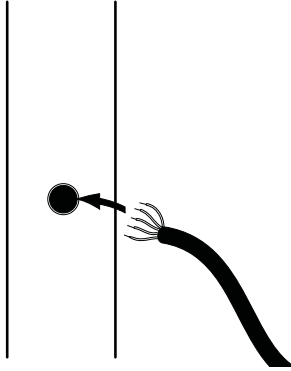

4) Install the motion box to the pole, e.g. by means of stainless steel bands (not provided by WE-EF).

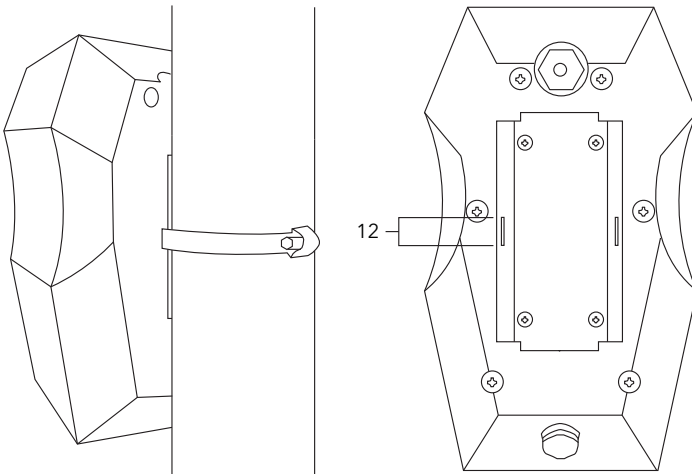

- 5) Trim the motion box cable to the desired length and connect leads to their respective terminals at the base of pole by means of the provided sealable junction box.

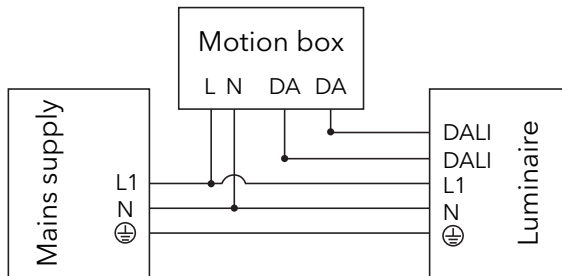

- 6) The configuration of the motion box is done via eSave SL configurator software and requires an eSave SL-Control USB stick. For further information, please contact WE-EF.

we-ef

www.we-ef.com

WE-EF LEUCHTEN

Germany

Tel +49 5194 909 0

Fax +49 5194 909 299

info.germany@we-ef.com

WE-EF LUMIERE

France

Tel +33 4 74 99 14 44

Fax +33 4 74 99 14 40

info.france@we-ef.com

WE-EF SWITZERLAND

Switzerland

Tel +41 22 752 49 94

Fax +41 22 752 49 74

info.switzerland@we-ef.com

WE-EF LIGHTING

Thailand

Tel +66 2 738 9610

Fax +66 2 175 2174

info.asiapacific@we-ef.com

WE-EF LIGHTING

Australia

Tel +61 3 8587 0444

Fax +61 3 8587 0499

info.australia@we-ef.com

WE-EF LIGHTING

United States of America

Tel +1 724 742 0030

Fax +1 724 742 0035

info.usa@we-ef.com

TO9281W0523 © WE-EF 2023

Technical specifications are
subject to change.