



WE-EF LEUCHTEN
Installation and Maintenance
Instructions

Inground Luminaire
ETC320-GB LED



Surge Protection

This product features built-in surge protection circuitry in compliance with applicable standards.

For comprehensive protection of a luminaire installation against lightning and electrical surges, it is essential to cover mains supply and data input lines at the distribution board level, by using respective primary (Type 1) and secondary (Type 2) surge arrestors in compliance with EN61643-11/IEC61643-1.

Warning

Ensure that all required surge protection measures are in place and activated prior to luminaire installation. Also, disconnect luminaires before operating high-power devices such as, for example, electrical arc welders.

Inground Luminaire

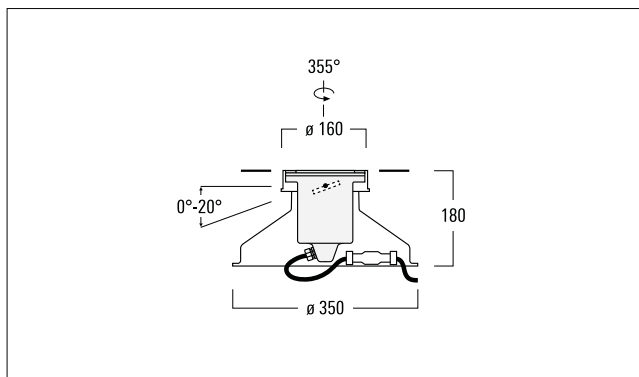

IP67, Class I, $t_a = 25^\circ\text{C}$

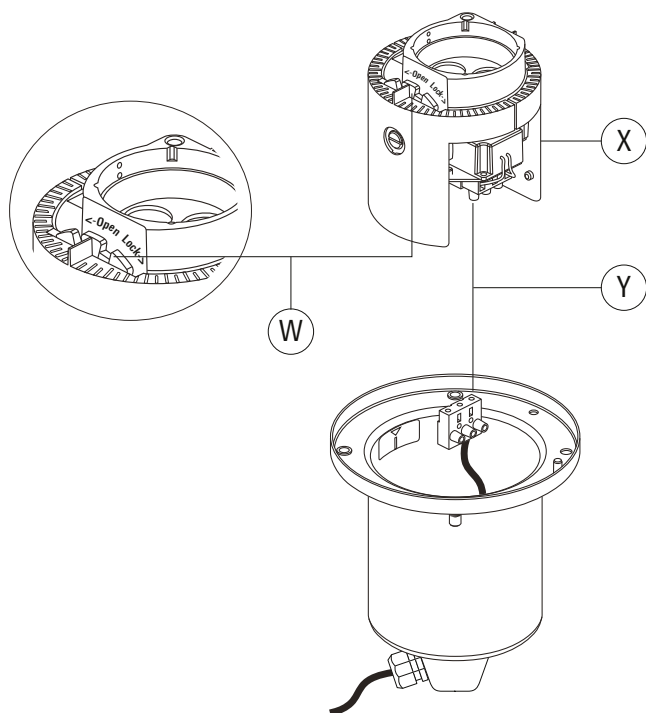

Fig. I

Light Source

LED

Maintenance

Warning: Do not open luminaire while mains supply is switched on.

- 1) Switch off mains electrical supply.
- 2) Remove cover and lens/gasket assembly. Clean all surfaces and ensure that threaded entries are free from dirt by using a wet cloth with mild detergent.
- 3) Check gasket for damage and replace if necessary.

Attention: In case of damage to the lens, the complete lens/gasket assembly must be replaced.

- 4) In case of damage to the LED, the complete gimbal module **X** must be returned to WE-EF for factory-maintenance (contact your authorised WE-EF agent for service). To remove the gimbal module proceed as follows (Fig. 1):
 - a) Rotate wheel **W** (using a standard tool) in the direction of the 'open' mark until the gimbal module can be pulled out of the luminaire housing.
 - b) Detach terminal connector **Y** and remove gimbal module **X**.
 - c) Properly package gimbal module **X** and return to WE-EF for factory-maintenance.

Attention: During the factory-maintenance period, ensure both the luminaire cover and lens are secured in position.
- 5) To install gimbal module **X**, attach terminal connector **Y**. Set gimbal module **X** into luminaire housing. Rotate wheel **W** in the direction of the 'lock' mark until gimbal module **X** is firmly secure. Follow steps 11-16 to close the luminaire (see: Phase Two – Luminaire Installation, Electrical Connection, and Aiming Procedure).

Damaged mains supply cable: Contact your authorised WE-EF agent for replacement.

Installation

The product must be installed and maintained by a suitably qualified professional in compliance with latest building/construction and/or electrical regulations and relevant legislation.

Warning: Switch off mains electrical supply prior to installing and connecting the luminaire.

Notice: If the luminaire is modified by anybody other than the original manufacturer, then the warranty will no longer be valid and shall become the full responsibility of the modifying person/organisation. Claims based on defects attributable to improper installation and/or application, and the consequences thereof, are excluded.

Installation Methods

For proper installation, use the supplied installation breakout.

Ensure that proper drainage is provided for the shown installation methods:

In landscape/paved areas, sand or concrete with gravel base (Fig. I).

With fully concreted installation, drainage piping must be provided (Fig. II).

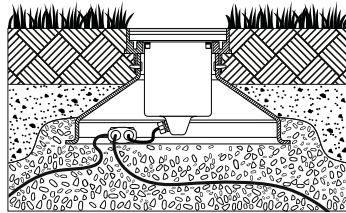

Fig. II

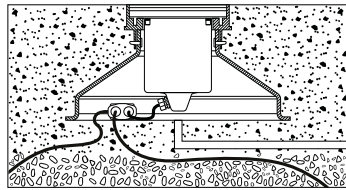

Fig. III

Phase One

Blockout Installation Procedure

(during earth or masonry work)

- 1) Ensure that proper drainage is provided for the shown installation methods.
- 2) Ensure a suitable recess is provided to accommodate installation blockout/mounting ring assembly **L/H**.
- 3) Test drainage (ensure water drains within 30 mins, Warning: warranty void if luminaire installed without appropriate drainage).
- 4) Set installation blockout/mounting ring assembly **L/H** in position and ensure that:
 - a) Arrow **R** on mounting ring **H** is pointed towards the object to be illuminated (wall, tree, column).
 - b) Mounting ring **H** is flush with surface **F**. If the floor will be tiled or paved afterwards, leave an appropriate gap.
 - c) Mains supply cable(s) **O** is of sufficient length to connect sealable junction box **J** with cable **N** from luminaire.
- 5) During ongoing earth and/or masonry works, do not remove screws **M** from mounting ring **H**. Ensure that installation blockout/mounting ring assembly **L/H** is not damaged and has maintained its original shape. If necessary use a cover plate.
- 6) Framing should be installed to prevent vegetation from growing over the lens.

Phase Two

Luminaire Installation, Electrical Connection, and Aiming Procedure

- 7) Switch off mains electrical supply.
- 8) Check that rating shown on luminaire label conforms with mains electrical supply.
- 9) Remove screws **M** from mounting ring **H**.
- 10) Terminate cable **N** and mains supply cable **O** in sealable junction box **J** and connect leads to respective terminals:
 - a) ON/OFF or wireless (L = Phase, N = Neutral, ⊕ = Earthing)
 - b) 1-10 V/DALI (L = Phase, N = Neutral, ⊕ = Earthing, DA/DA = DALI control line, D-/D+ = 1-10 V control line).Please refer to instruction inside SJB packaging.
- 11) Remove cover **A** and lens/gasket assembly **B** by loosening screws **D**.
- 12) Set cables and sealable junction box **J** inside installation blackout **L**.
- 13) Place luminaire housing **C** into installation block-out/mounting ring assembly **L/H**. Secure luminaire with mounting ring **H** by tightening screws **M**.
Warning: When luminaire is placed inside installation blackout **L**, ensure there is no stress on sealable junction box **J** or electric cables (Fig. IV).

Aiming of gimbal

- 14) Insert a standard tool into a slot on locking wheel **W**. Rotate locking wheel **W** in the 'OPEN' direction until gimbal can be moved (Fig. V).
To horizontally aim the gimbal
(Rotation 355°)
Hold fins **E** to rotate the gimbal.
To vertically aim the gimbal
(Tilt 0-20°)
 - a) Insert screw driver into hole **T**.
 - b) Adjust gimbal to desired angle (Refer to protractor scale **U**).**Note:** Angle can be adjusted in 2° increments.
- 15) Insert screw driver into a slot on locking wheel **W**. Rotate locking wheel **W** in the 'LOCK' direction until the gimbal is firmly secured (Fig. V).
Warning: Do not tighten more than necessary to secure gimbal.
- 16) Ensure that all surfaces are clean and dry. Reposition lens/gasket assembly **B**, cover **A** and screws **D** on luminaire housing **C**.
Note: Ensure that orientation pin **P** is align with hole **Q** in gasket (Fig. VI).
- 17) Switch on mains electrical supply and operate light source for approximately 30 minutes to dry any moisture.
Attention: Do not switch off LED before luminaire is properly sealed.
- 18) Secure cover **A** as follow:
 - a) Partially secure screws **D** in criss-cross sequence (Fig. VII) starting from position 1.
 - b) Tighten screws **D** in same sequence.
 - c) Fully tighten screws **D** in same sequence again, using torque 3 Nm.

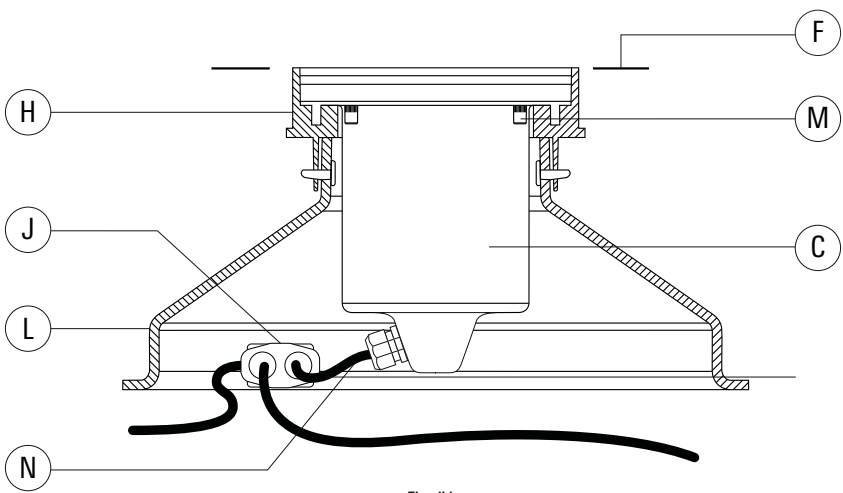
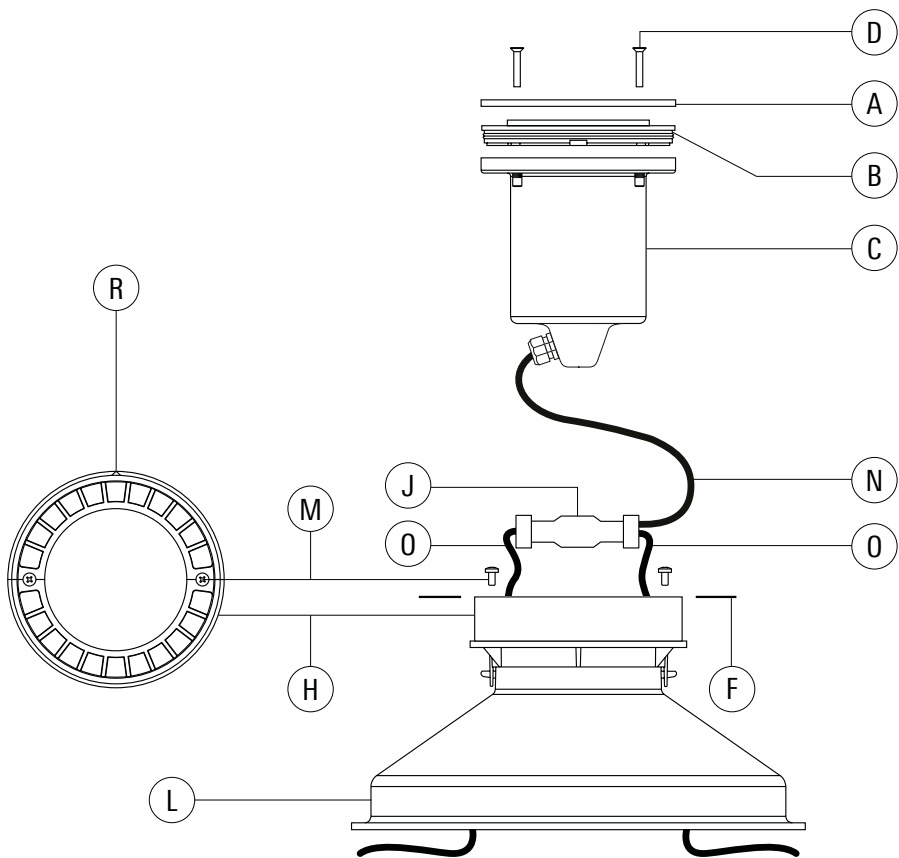

Fig. IV

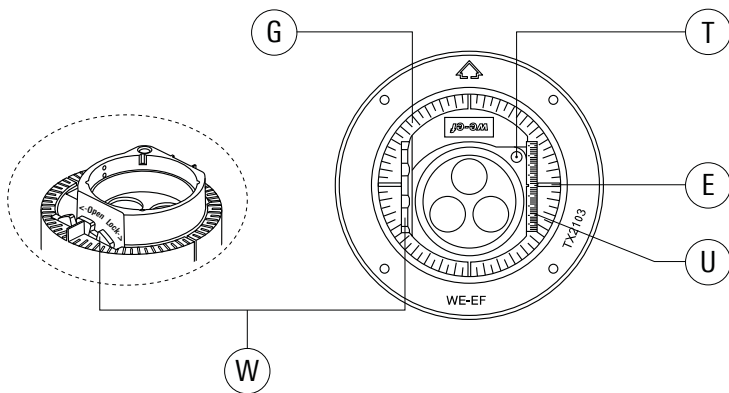

Fig. V

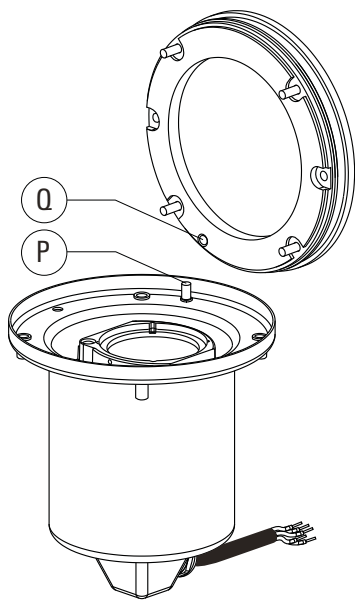

Fig. VI

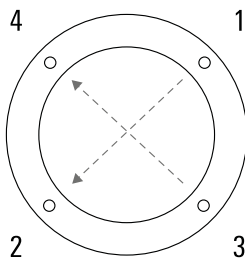

Fig. VII

we-ef

www.we-ef.com

WE-EF LEUCHTEN

Germany

Tel +49 5194 909 0

Fax +49 5194 909 299

info.germany@we-ef.com

WE-EF LIGHTING

Thailand

Tel +66 2 738 9610

Fax +66 2 175 2174

info.asiapacific@we-ef.com

WE-EF LUMIERE

France

Tel +33 4 74 99 14 44

Fax +33 4 74 99 14 40

info.france@we-ef.com

WE-EF LIGHTING

Australia

Tel +61 3 8587 0444

Fax +61 3 8587 0499

info.australia@we-ef.com

WE-EF HELVETICA

Switzerland

Tel +41 22 752 49 94

Fax +41 22 752 49 74

info.switzerland@we-ef.com

WE-EF LIGHTING

United States of America

Tel +1 724 742 0030

Fax +1 724 742 0035

info.usa@we-ef.com

T09191W0621 © WE-EF 2021

Technical specifications are
subject to change.

WE-EF LIGHTING

Installation and Maintenance

Instructions

GEL JUNCTION BOX, c/w 6 mm T/B

185-1624

These instructions cover wiring of luminaires for different lighting control systems:

- 1) Wiring instructions for ON/OFF, 1-10V or DALI luminaires
- 2) Wiring instructions for DMX luminaires

see page 2
see page 7

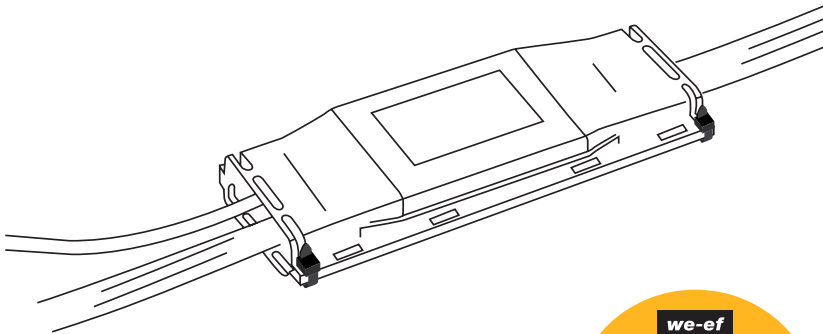

Watch a step-by-step installation guide for the IP68 gel junction box, using the QR code. Or here is a short link: <https://bit.ly/3y7dHCs>



Installation

This instruction sheet is specific to underground standard cable connections for inground up-lights supplied by WE-EF complete with pre-installation blockout. This product is designed for single use only.

It is also specific to a maximum of two x 5 core (1.5 mm² to 4 mm²) circular or flat TPS. Installations using larger and/or alternate cables are not covered by this instruction sheet, please refer to your supplier for approved instruction information.

The product must be installed and maintained by a suitably qualified professional in compliance with latest building/construction and/or electrical regulations and relevant legislation.

The installation on site must comply with local and/or national health and safety instructions.

Installation Procedure - ON/OFF, 1-10V or DALI luminaires

1) Prepare cables

a) ON/OFF

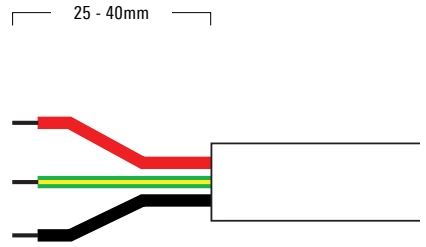
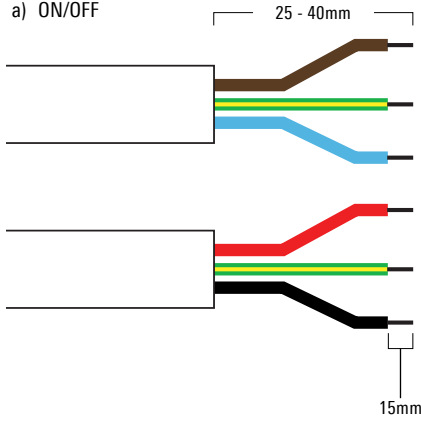

b) DALI/1-10V*

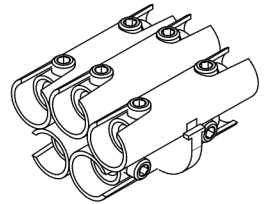
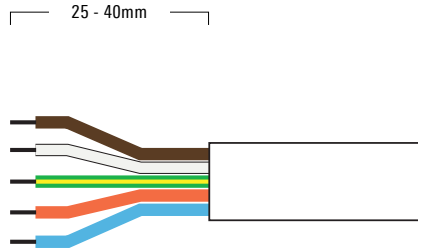
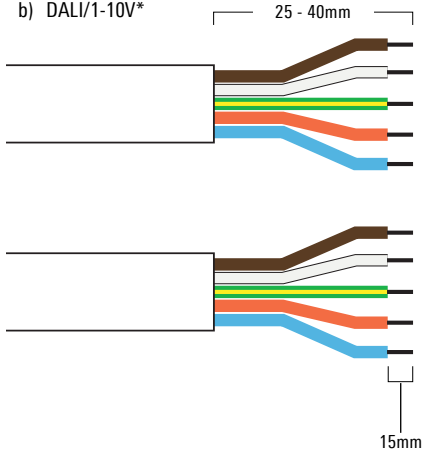

As supplied with fixture

*Confirm suitability of 1-10V connections as shown

2) Secure wires within terminal block with hex key supplied

a) ON/OFF

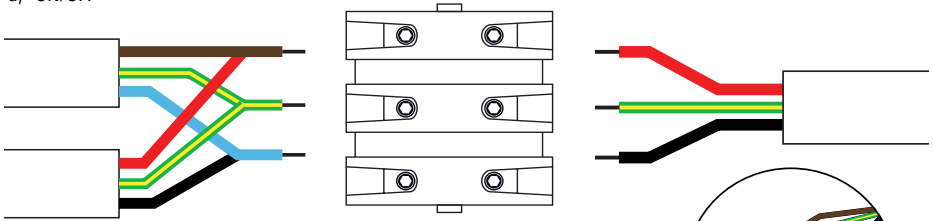

b) DALI/1-10V*

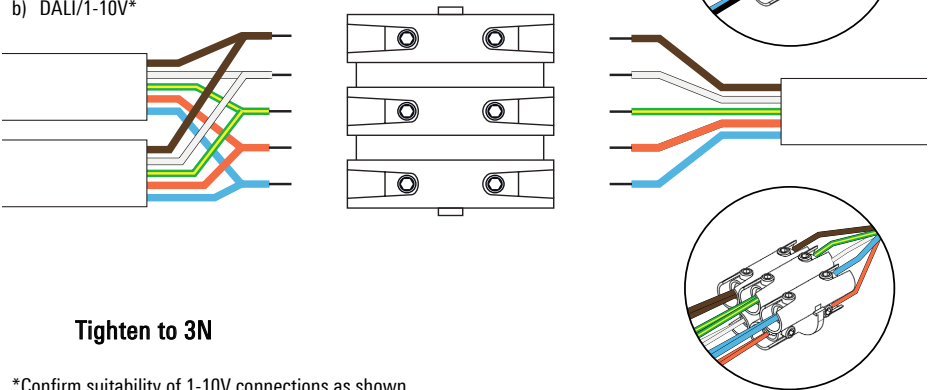

Tighten to 3N

*Confirm suitability of 1-10V connections as shown

3) Placement inside junction box

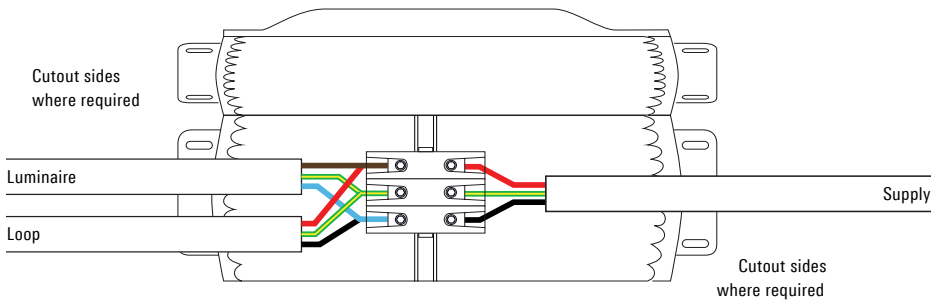

4) Click closed the junction box

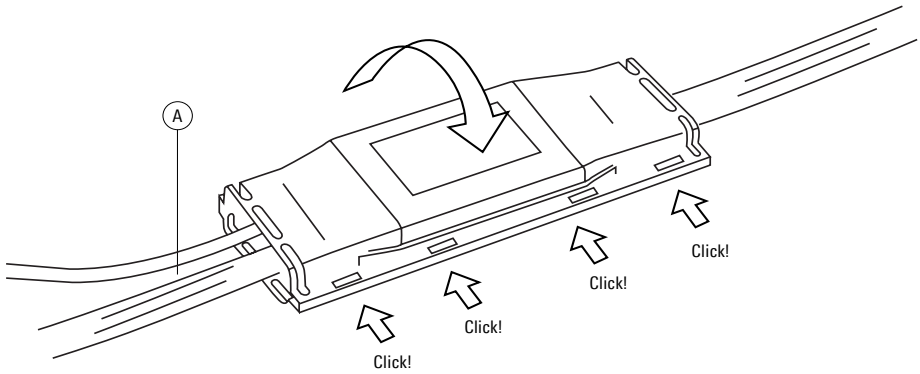

* Separate **A** – Do not lay cables on top of each other

5) Ensure gel dispersion

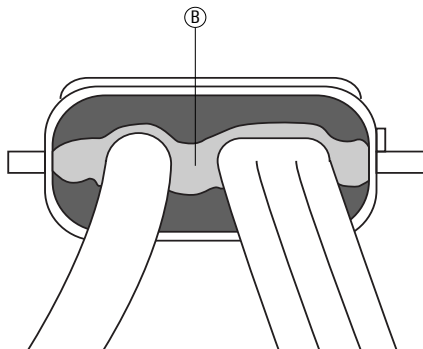

** **B** – Be sure to have gel dispersion between cables

6) Cable ties are for locking case at end

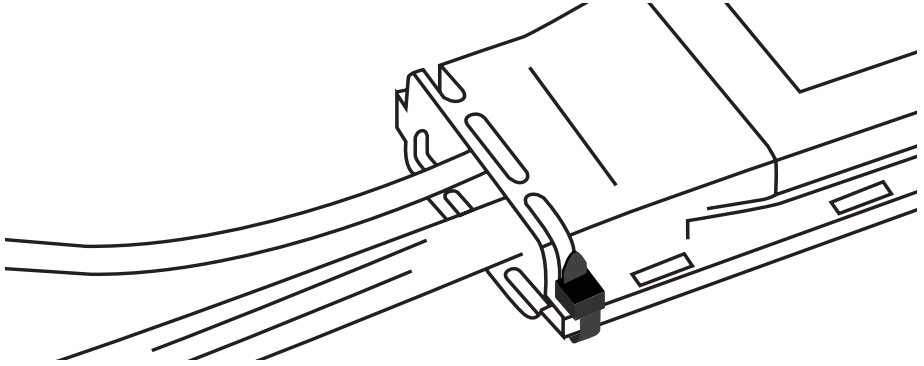

7) Power up

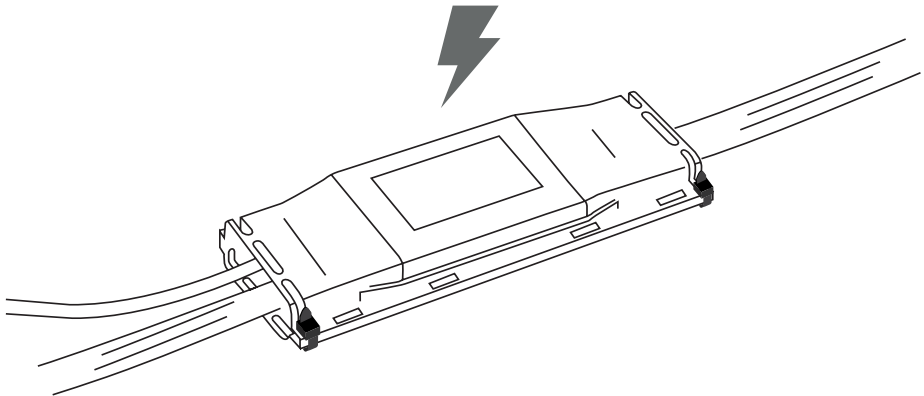

Installation Procedure - DMX luminaires

1) Scope of supply.

(illustrations are exemplary)

A: Power supply cable

B: DMX data cable

C: Junction box for DMX data cables

D: Junction box for power supply cable

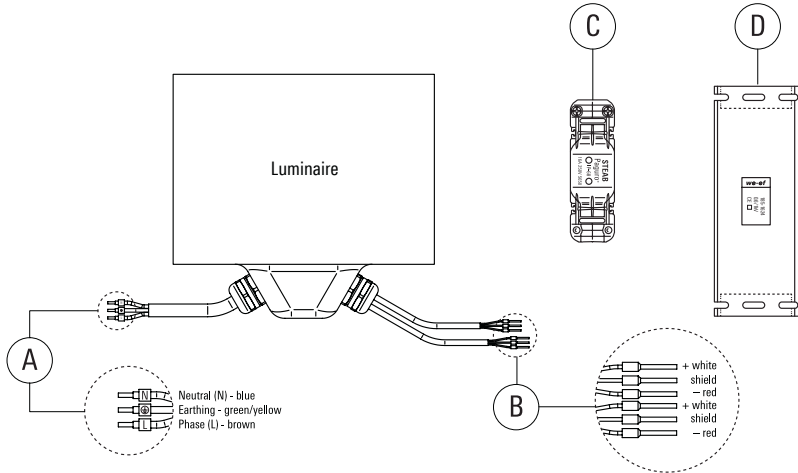

2) Overview.

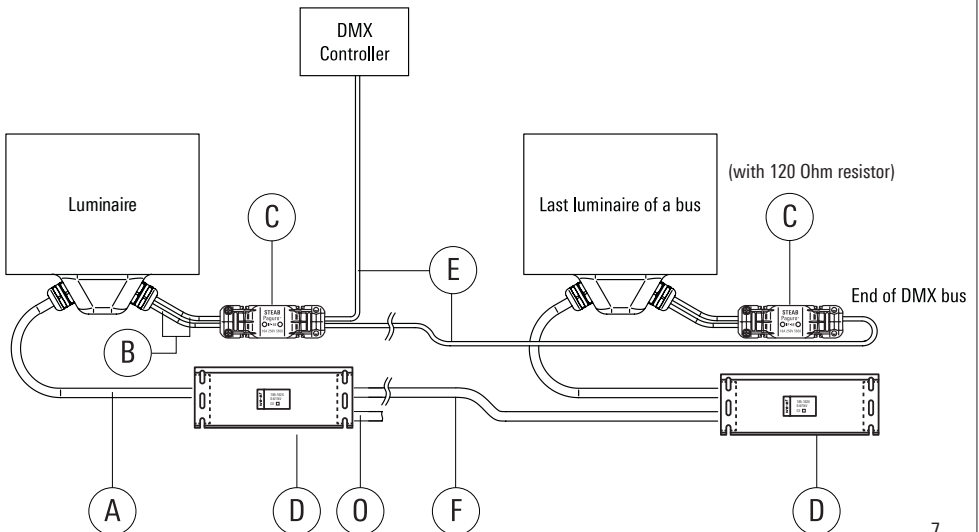

- 3) Connect luminaire's power supply cable **A** and main supply cable **O** (and second cable **F** for through wiring) to terminal block **H** within junction box **D**: L = Phase, N = Neutral, ⊕ = Earthing.
Attention: Refer to additional information packed with junction box **D** (shown wiring is exemplary only).

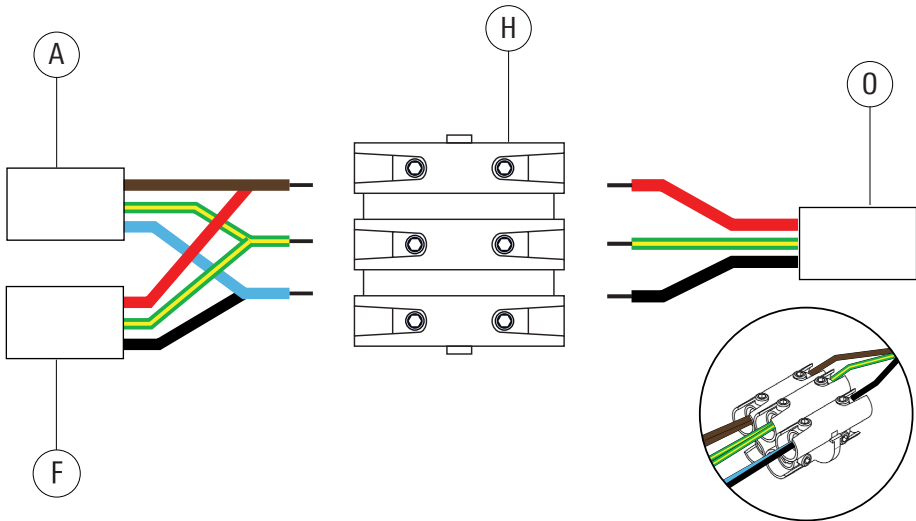

- 4) Click closed the junction box, ensure cables do not lay on top of each other

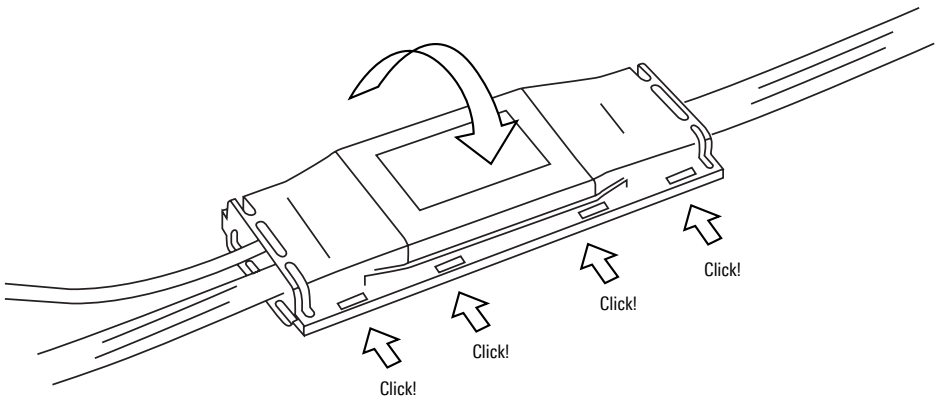

5) Ensure gel dispersion, and that individual insulation of cable cores is totally enclosed in the gel.

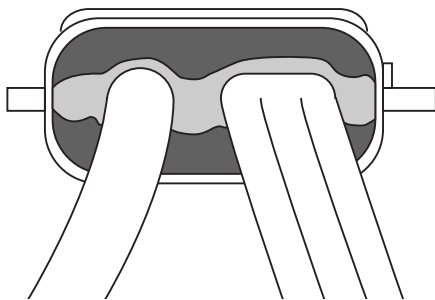

6) Tie the ends of the case closed with cable ties **K**

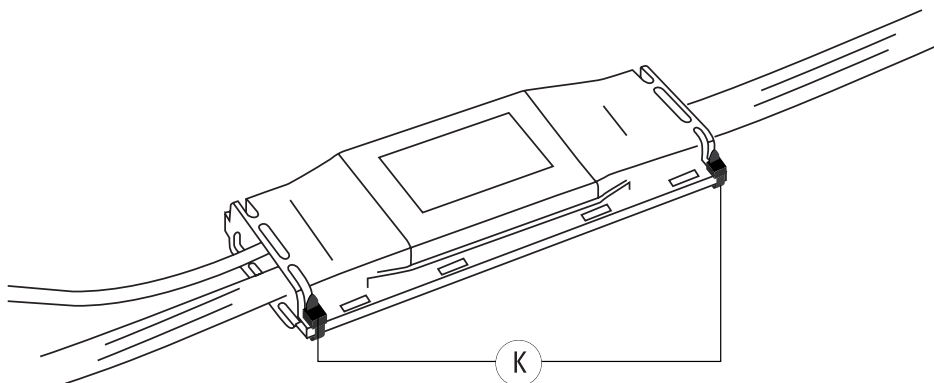

7) Connect luminaire's DMX data cables **B** and external DMX cables **E** to terminal block **I** within junction box **C**: White = DMX+, Red = DMX-, Shield. Use cord-end terminals for DMX wires.

Attention: Refer to additional information packed with junction box **C** (shown wiring is exemplary only).

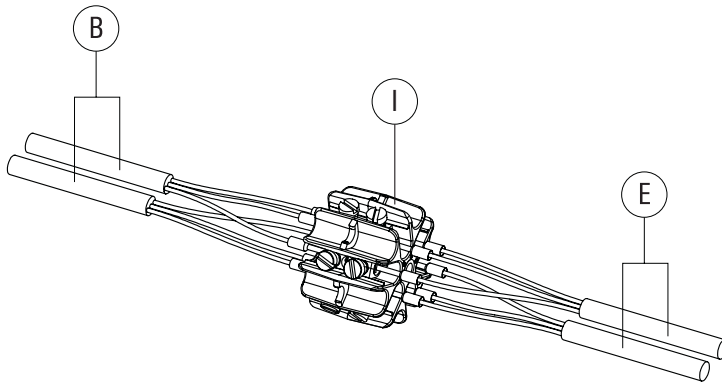

8) At the end of each DMX bus: DMX must be terminated by connecting 120 ohm resistor **G** (placed on each junction box **C** by adhesive type) between DMX+ and DMX- on terminal block **I** in junction box **C**.

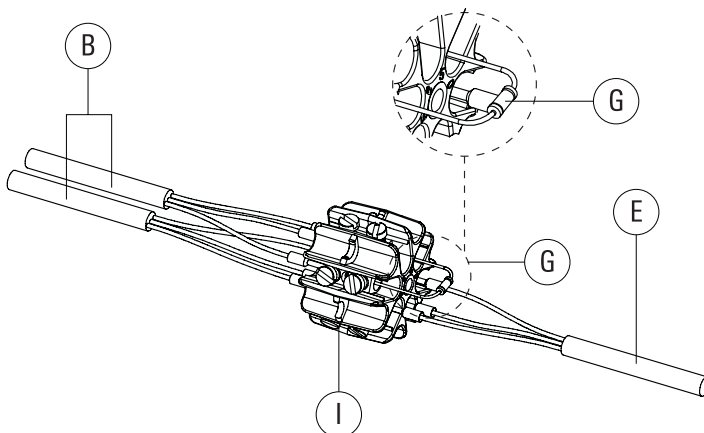

- 9) Ensure cables do not cross and that cable sheaths are contained with gel.
Tighten 4 screws.

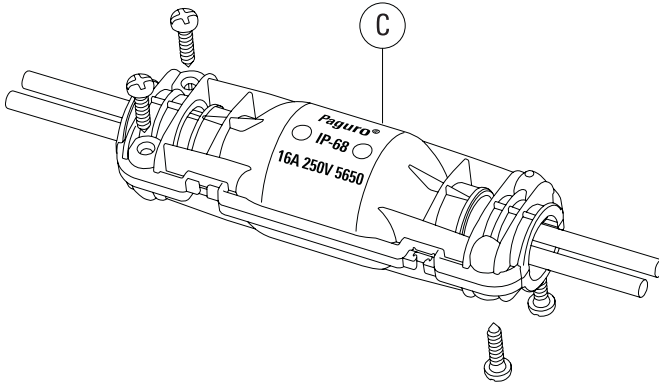

- 10) Test electrical system before burying cables.

Drainage

- 1) Ensure that proper drainage is provided for the shown installation methods:
 - a) In landscape/paved areas, sand or concrete with gravel base (Fig. I).
 - b) With fully concreted installation, drainage piping must be provided (Fig. II).

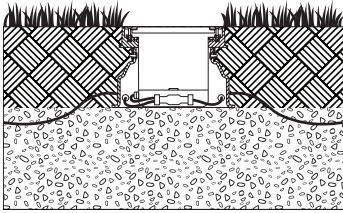

Fig. I

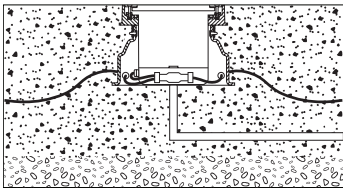
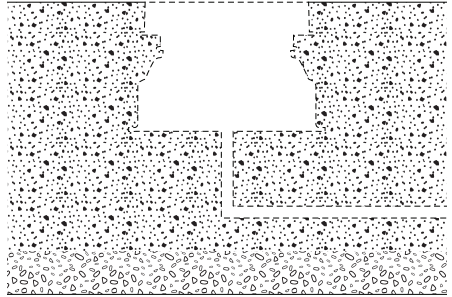

Fig. II

- 2) Ensure a suitable recess.



- 3) Test drainage (ensure water drains within 30 mins, **Warning:** warranty void if luminaire installed without appropriate drainage)

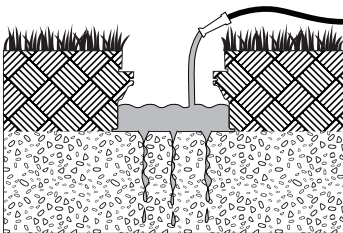

Fig. I

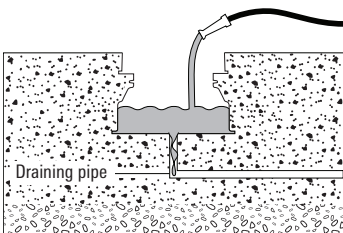
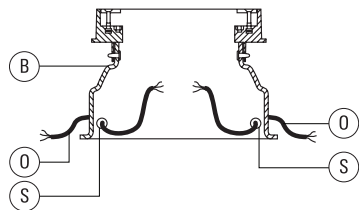

Fig. II

- 4) Select appropriate installation breakout holes **S** for mains supply cable(s) **O** and data cable(s) if necessary.



WE-EF LEUCHTEN

Germany

Tel +49 5194 909 0

Fax +49 5194 909 299

info.germany@we-ef.com**WE-EF LUMIERE**

France

Tel +33 4 74 99 14 44

Fax +33 4 74 99 14 40

info.france@we-ef.com**WE-EF HELVETICA**

Switzerland

Tel +41 22 752 49 94

Fax +41 22 752 49 74

info.switzerland@we-ef.com**WE-EF LIGHTING**

Thailand

Tel +66 2 738 9610

Fax +66 2 175 2174

info.asiapacific@we-ef.com**WE-EF LIGHTING**

Australia

Tel +61 3 8587 0444

Fax +61 3 8587 0499

info.australia@we-ef.com**WE-EF LIGHTING**

United States of America

Tel +1 724 742 0030

Fax +1 724 742 0035

info.usa@we-ef.com