

## **WE-EF LEUCHTEN** Installation and Maintenance Instructions

Bracket Mounted Projector

**FLC121 #4 LED**

**FLC131 #4 LED**

**FLC141 #4 LED**



### **Do not open during installation**

This product is factory-sealed.  
Refer to the instructions contained in this document for details.



### **Surge Protection**

This product features built-in surge protection circuitry in compliance with applicable standards.

For comprehensive protection of a luminaire installation against lightning and electrical surges, it is essential to cover mains supply and data input lines at the distribution board level, by using respective primary (Type 1) and secondary (Type 2) surge arrestors in compliance with EN61643-11/ IEC61643-1.

### **Warning**

Ensure that all required surge protection measures are in place and activated prior to luminaire installation. Also, disconnect luminaires before operating high-power devices such as, for example, electrical arc welders.

# Projector

## FLC121 #4

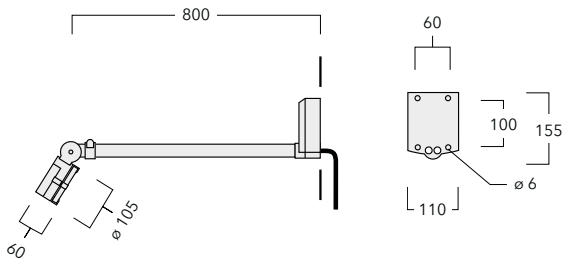

## FLC131 #4

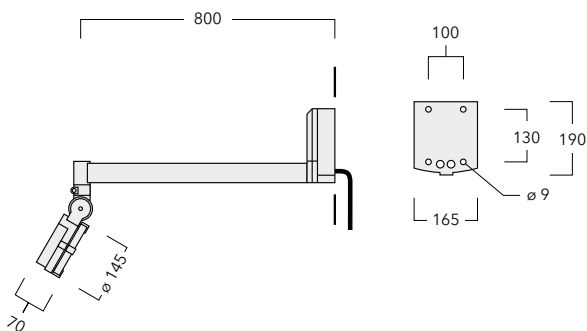

## FLC141 #4

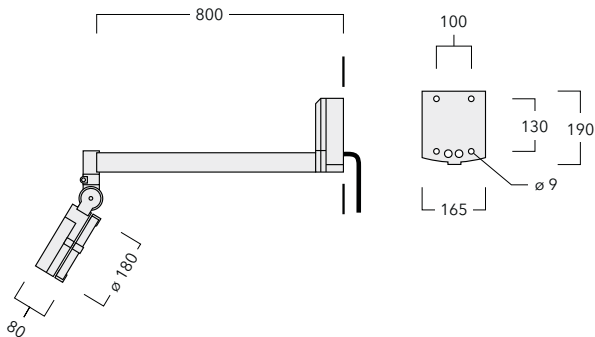

IP55, IK07. Class I,  $t_a = 40^\circ\text{C}$

### Weight

kg

for FLC121 #4

2.9

for FLC131 #4

4.5

for FLC141 #4

5.8

**Light Source**

LED

**Maintenance**

Apart from cleaning the product's exterior surfaces, no special maintenance work is required.

Do not use high-pressure cleaners.

In case of component failure due to abnormal circumstances or at end of life, replacement must be carried out by a suitably qualified and trained professional.

**Warning:** Do not open luminaire while mains supply is switched on.

## **Installation**

The product must be installed and maintained by a suitably qualified professional in compliance with latest building/construction and/or electrical regulations and relevant legislation.

**Warning:** Switch off mains electrical supply prior to installing and connecting the luminaire.

**Notice:** If the luminaire is modified by anybody other than the original manufacturer, then the warranty will no longer be valid and shall become the full responsibility of the modifying person/organisation. Claims based on defects attributable to improper installation and/or application, and the consequences thereof, are excluded.

The installation on site must comply with local and/or national health and safety regulations.

## Installation Procedure

- 1) Switch off mains electrical supply.

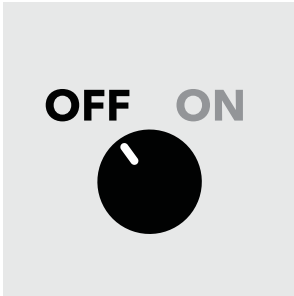

- 2) Remove mounting flange **A** by loosening screws **B**. Detach terminal connector **C**.

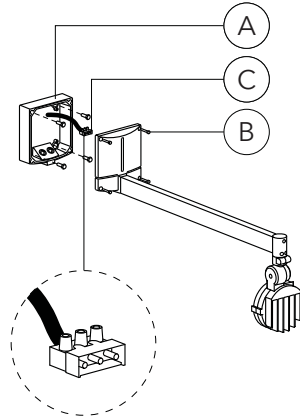

- 3) Determine position for fixing screws **D**. Drill relevant holes **E** and insert nylon plugs **F**.  
**Warning:** Ensure not to damage any electrical cable, water pipe or other items drilling holes.

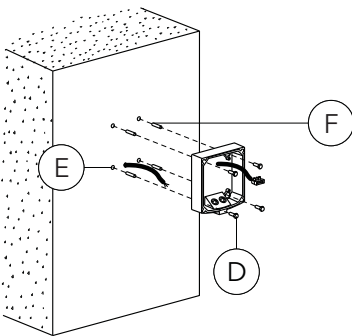

- 4) Feed mains supply cable **G** (and second cable **H** for through wiring, if required) through membrane spout(s) **I**, while setting mounting flange **A** in position.

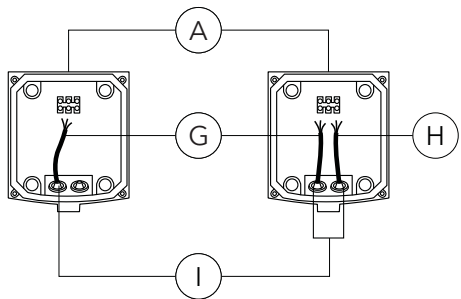

- 5) To fix mounting flange **A**, pierce through nylon plugs **J** by inserting and tightening screws **D**.

**Attention:** Nylon plugs **J** must remain in position to provide sealing.

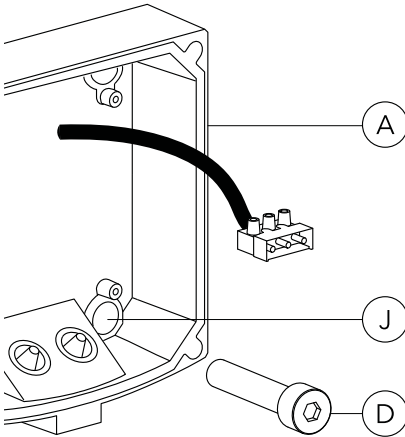

- 6) Check that rating shown on luminaire label conforms with mains electrical supply.

**we-ef**

12/17 IP55 **CE**

**FLC121-LED** → 220-240V50-60/Hz

145-XXXX

SOE XXXXXXXX

LED 3000K 12W item no. XXX

(example)

- 7) Connect mains supply cable **G** leads to respective terminals in terminal connector **K**:

**K:**

a) ON/OFF (L = Phase, N = Neutral,

⊕ = Earthing)

b) 1-10 V/DALI (L = Phase, N = Neutral,

⊕ = Earthing, DA/DA = DALI control line,

D-/D+ = 1-10 V control line).

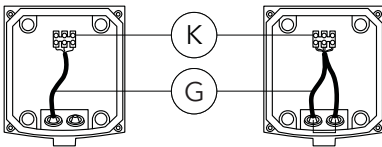

- 8) Ensure that all surfaces are clean and dry. Position luminaire over mounting flange **A** and attach terminal connector **C**. Tighten screws **B**.

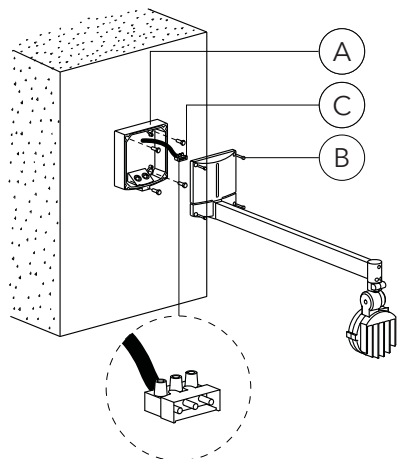

- 9) Loosen screws **M** and **N** slightly. Aim luminaire in desired direction, retighten screws **M** and **N**.

**Attention:** The luminaire is pre-assembled for downward lighting applications as illustrated. To aim upwards, loosen screws **P** and rotate head assembly 180 degrees. Then retighten screws.

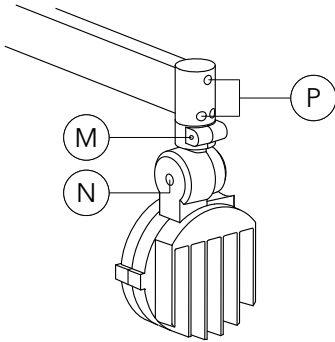

# **we-ef**

[www.we-ef.com](http://www.we-ef.com)

## **WE-EF LEUCHTEN**

Germany

Tel +49 5194 909 0

Fax +49 5194 909 299

[info.germany@we-ef.com](mailto:info.germany@we-ef.com)

## **WE-EF LUMIERE**

France

Tel +33 4 74 99 14 44

Fax +33 4 74 99 14 40

[info.france@we-ef.com](mailto:info.france@we-ef.com)

## **WE-EF SWITZERLAND**

Switzerland

Tel +41 22 752 49 94

Fax +41 22 752 49 74

[info.switzerland@we-ef.com](mailto:info.switzerland@we-ef.com)

## **WE-EF LIGHTING**

Thailand

Tel +66 2 738 9610

Fax +66 2 175 2174

[info.asiapacific@we-ef.com](mailto:info.asiapacific@we-ef.com)

## **WE-EF LIGHTING**

Australia

Tel +61 3 8587 0444

Fax +61 3 8587 0499

[info.australia@we-ef.com](mailto:info.australia@we-ef.com)

## **WE-EF LIGHTING**

United States of America

Tel +1 724 742 0030

Fax +1 724 742 0035

[info.usa@we-ef.com](mailto:info.usa@we-ef.com)

TO9208W0823 © WE-EF 2023

Technical specifications are  
subject to change.