

## WE-EF LEUCHTEN

Installation and Maintenance  
Instructions

Inground Luminaire

**ETV100 LED**



### **Do not open during installation**

This product is factory-sealed.  
Refer to the instructions contained in this document for details.



### **Surge Protection**

This product features built-in surge protection circuitry in compliance with applicable standards.

For comprehensive protection of a luminaire installation against lightning and electrical surges, it is essential to cover mains supply and data input lines at the distribution board level, by using respective primary (Type 1) and secondary (Type 2) surge arrestors in compliance with EN61643-11/ IEC61643-1.

### **Warning**

Ensure that all required surge protection measures are in place and activated prior to luminaire installation. Also, disconnect luminaires before operating high-power devices such as, for example, electrical arc welders.

# Inground Luminaire

## ETV100

### Product Dimensions:

ETV100 series	L
ETV120	627
ETV130/ETV130-CC	927
ETV140/ETV140-CC	1227



IP69, IK08. Class I.  $t_a = 25^\circ\text{C}$

### Mounting Accessories:

#### Installation blackout

	Type I	Type II	A
	B = 160 mm	B = 130 mm	
for 1 x ETV120	<b>186-0306</b>	<b>186-0281</b>	675
for 2 x ETV120	<b>186-0307</b>	<b>186-0282</b>	1304
for 3 x ETV120	<b>186-0308</b>	<b>186-0283</b>	1933
for 4 x ETV120	<b>186-0309</b>	<b>186-0284</b>	2562
for 1 x ETV130/ETV130-CC	<b>186-0310</b>	<b>186-0285</b>	975
for 2 x ETV130/ETV130-CC	<b>186-0311</b>	<b>186-0286</b>	1905
for 3 x ETV130/ETV130-CC	<b>186-0312</b>	<b>186-0287</b>	2833
for 4 x ETV130/ETV130-CC	<b>186-0313</b>	<b>186-0288</b>	3762
for 1 x ETV140/ETV140-CC	<b>186-0314</b>	<b>186-0289</b>	1275
for 2 x ETV140/ETV140-CC	<b>186-0315</b>	<b>186-0290</b>	2504
for 3 x ETV140/ETV140-CC	<b>186-0316</b>	<b>186-0291</b>	3733
for 4 x ETV140/ETV140-CC	<b>186-0317</b>	<b>186-0292</b>	4962

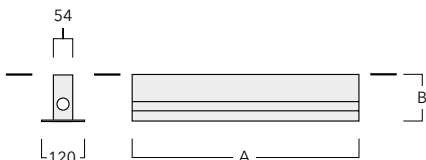

	d:h
[A6]	1:10
[LA10]	1:5

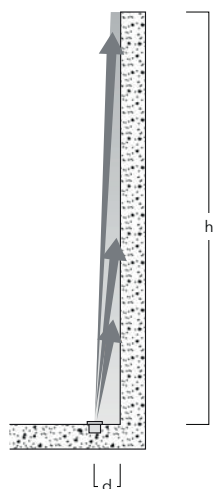

**Light Source**

LED

**Maintenance**

Apart from cleaning the product's exterior surfaces, no special maintenance work is required.

Do not use high-pressure cleaners.

In case of component failure due to abnormal circumstances or at end of life, replacement must be carried out by a suitably qualified and trained professional.

**Warning:** Do not open luminaire while mains supply is switched on.

For operation with Tunable White, a DALI DT8 controller is required.

## **Installation**

The product must be installed and maintained by a suitably qualified professional in compliance with latest building/construction and/or electrical regulations and relevant legislation.

**Warning:** Switch off mains electrical supply prior to installing and connecting the luminaire.

**Notice:** If the luminaire is modified by anybody other than the original manufacturer, then the warranty will no longer be valid and shall become the full responsibility of the modifying person/organisation. Claims based on defects attributable to improper installation and/or application, and the consequences thereof, are excluded.

**Attention:** The luminaire is factory-sealed and does not need to be opened during installation.

The installation on site must comply with local and/or national health and safety regulations.

## Blockout Installation Procedure

(during earth or masonry work)

- 1) Ensure that proper drainage is provided for the shown installation methods:
  - a) In landscape/paved areas, sand or concrete with gravel base (Fig. I).
  - b) With fully concreted installation, drainage piping must be provided (Fig. II).

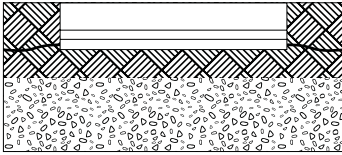

Fig. I

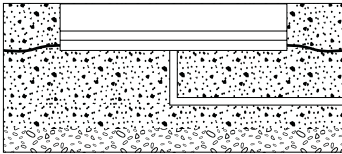
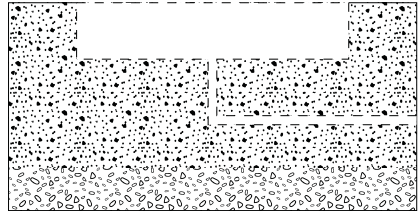

Fig. II

- 2) Ensure a suitable recess.



- 3) Test drainage (ensure water drains within 30 mins, **Warning:** warranty void if luminaire installed without appropriate drainage)

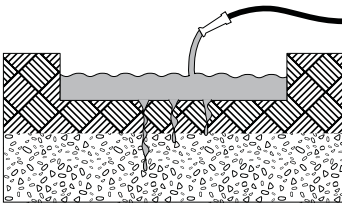

Fig. I

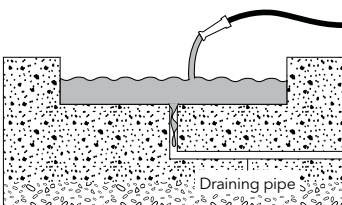
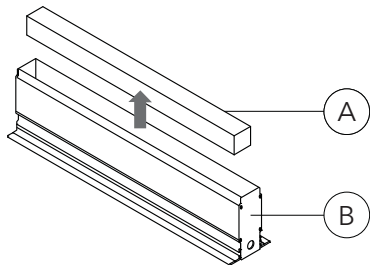
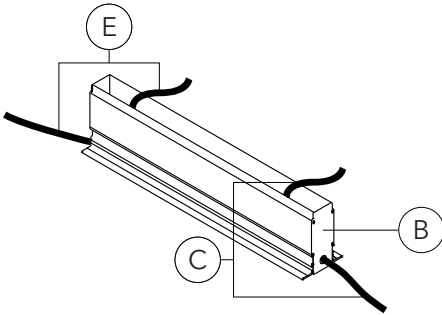

Fig. II

- 4) Remove installation cover **A** out of installation blockout **B**.



- 5) Feed mains supply cable **C** (and second cable **E** for through wiring) through holes inside blackout.



- 6) Place mains cable **C** (and second cable **E** for through wiring) at bottom area of blackout, then return installation cover **A**.

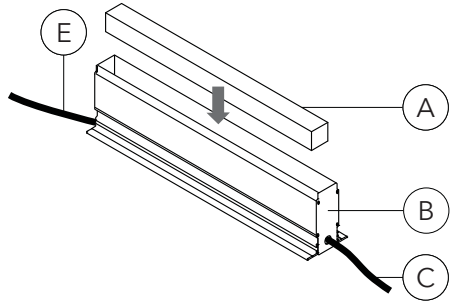

- 7) Blockout needs to get placed on an even, stable area. Top edge needs to be flush with surface.

**Attention:** If floor will be tiled or paved afterwards leave an appropriate gap. In case luminaire gets installed at a later time, blackout must get covered by installation cover **A**, to make sure no concrete or dirt may enter luminaire. Installation cover ensures that blackout does not get damaged during masonry works and needs to remain inside blackout until installation of luminaire.

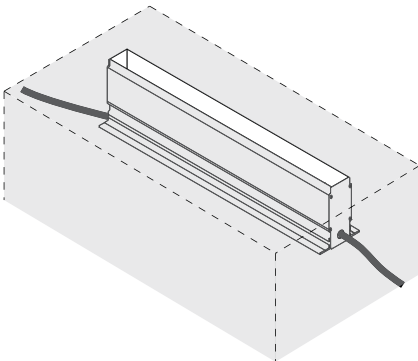

- 8) Framing should be installed to prevent vegetation from growing over the lens.

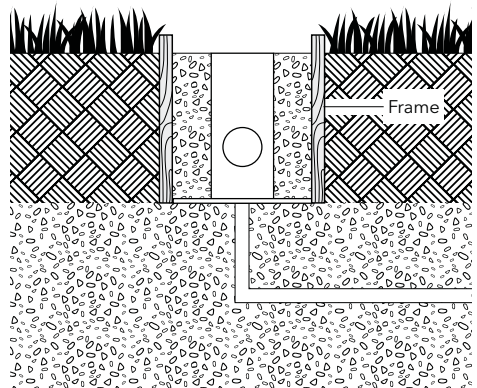

## Luminaire Installation Procedure

9) Switch off mains electrical supply.

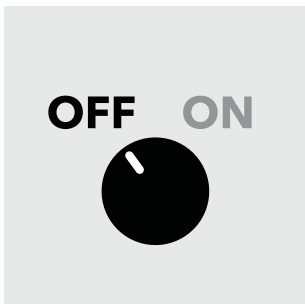

10) Check that rating shown on luminaire label conforms with mains electrical supply.

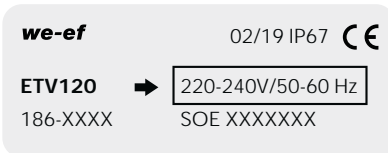

(example)

11) Luminaire is pre-wired and LED included.  
Opening the luminaire is not necessary.

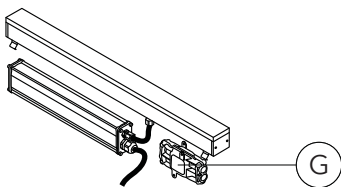

12) Remove installation cover **A** from blackout **B**.

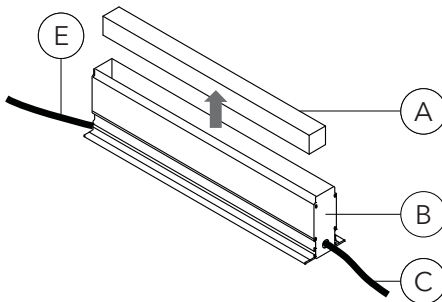



13) Take sealable junction box **G** from its bag and open it.

**Warning:** Be careful to not get dirt inside the gel connector when opened and connecting mains cable. Connect leads of luminaire cable **D** and mains supply cable **C** (and second cable **E** for through wiring) to respective terminals in terminal connector **F**. Mains cables **C** and **E** must not cross to ensure sealable junction box **G** can be properly closed.

a) ON/OFF (L = Phase, N = Neutral, ⊕ = Earthing)

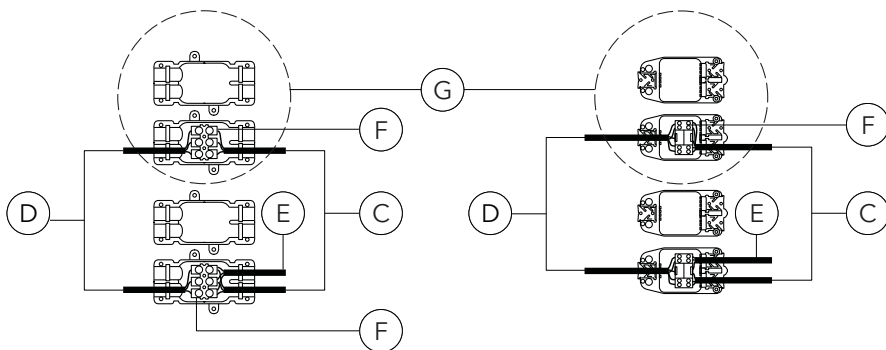
b) DALI (L = Phase, N = Neutral, ⊕ = Earthing, DA/DA = DALI control line, DA/DA = DALI control line)



∅ 7.5-16 mm for ON/OFF 

∅ 6.5-12 mm for DALI 

c) DMX: refer to separate TO9256W wiring instruction for hybrid DMX cable.

**Attention:**

- a) To properly terminate and seal cables with sealable junction box, refer to information packed with each sealable junction box **G**.
- b) Cable sheaths must be contained within gel.

For operation with Tunable White, a DALI DT8 controller is required.

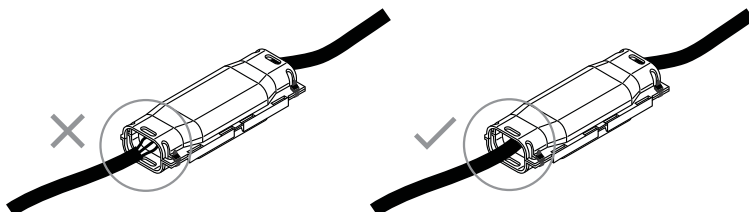



14) Place sealable junction box **G** and luminaire **H** inside blockout. Make sure no cable is squeezed.

**Attention:** For [LA10] and [A6], ensure correct orientation of the luminaire. Remove label before operation of luminaire.

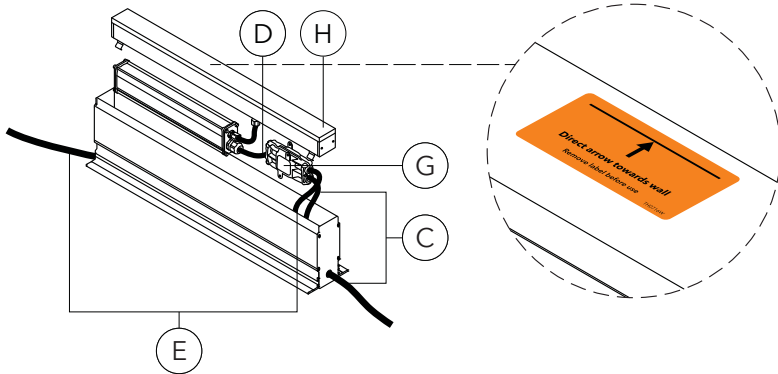

15) Install spacers **I**.

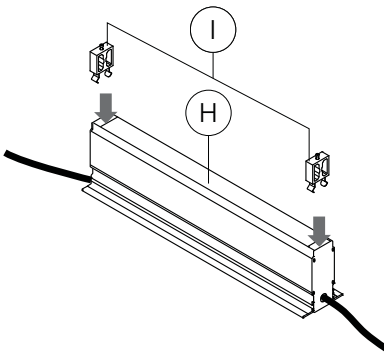

16) To remove luminaire unfasten screws **K** out of spacers **I** until you can grab their heads. Insert lever **L** between head of screws and spacers. Lift spacers in an upwards direction.

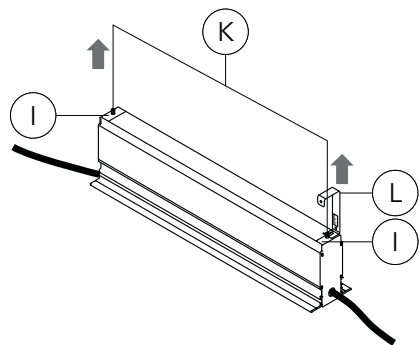

# **we-ef**

[www.we-ef.com](http://www.we-ef.com)

## **WE-EF LEUCHTEN**

Germany

Tel +49 5194 909 0

Fax +49 5194 909 299

[info.germany@we-ef.com](mailto:info.germany@we-ef.com)

## **WE-EF LUMIERE**

France

Tel +33 4 74 99 14 44

Fax +33 4 74 99 14 40

[info.france@we-ef.com](mailto:info.france@we-ef.com)

## **WE-EF SWITZERLAND**

Switzerland

Tel +41 22 752 49 94

Fax +41 22 752 49 74

[info.switzerland@we-ef.com](mailto:info.switzerland@we-ef.com)

## **WE-EF LIGHTING**

Thailand

Tel +66 2 738 9610

Fax +66 2 175 2174

[info.asiapacific@we-ef.com](mailto:info.asiapacific@we-ef.com)

## **WE-EF LIGHTING**

Australia

Tel +61 3 8587 0444

Fax +61 3 8587 0499

[info.australia@we-ef.com](mailto:info.australia@we-ef.com)

## **WE-EF LIGHTING**

United States of America

Tel +1 724 742 0030

Fax +1 724 742 0035

[info.usa@we-ef.com](mailto:info.usa@we-ef.com)

TO9258W0823 © WE-EF 2023

Technical specifications are  
subject to change.