

# **we-ef**

## **WE-EF LEUCHTEN**

Installation and Maintenance  
Instructions

Pole Mounted Lighting  
Luminaire

**VFL500 LED Series**  
**VFL500-SE LED Series**

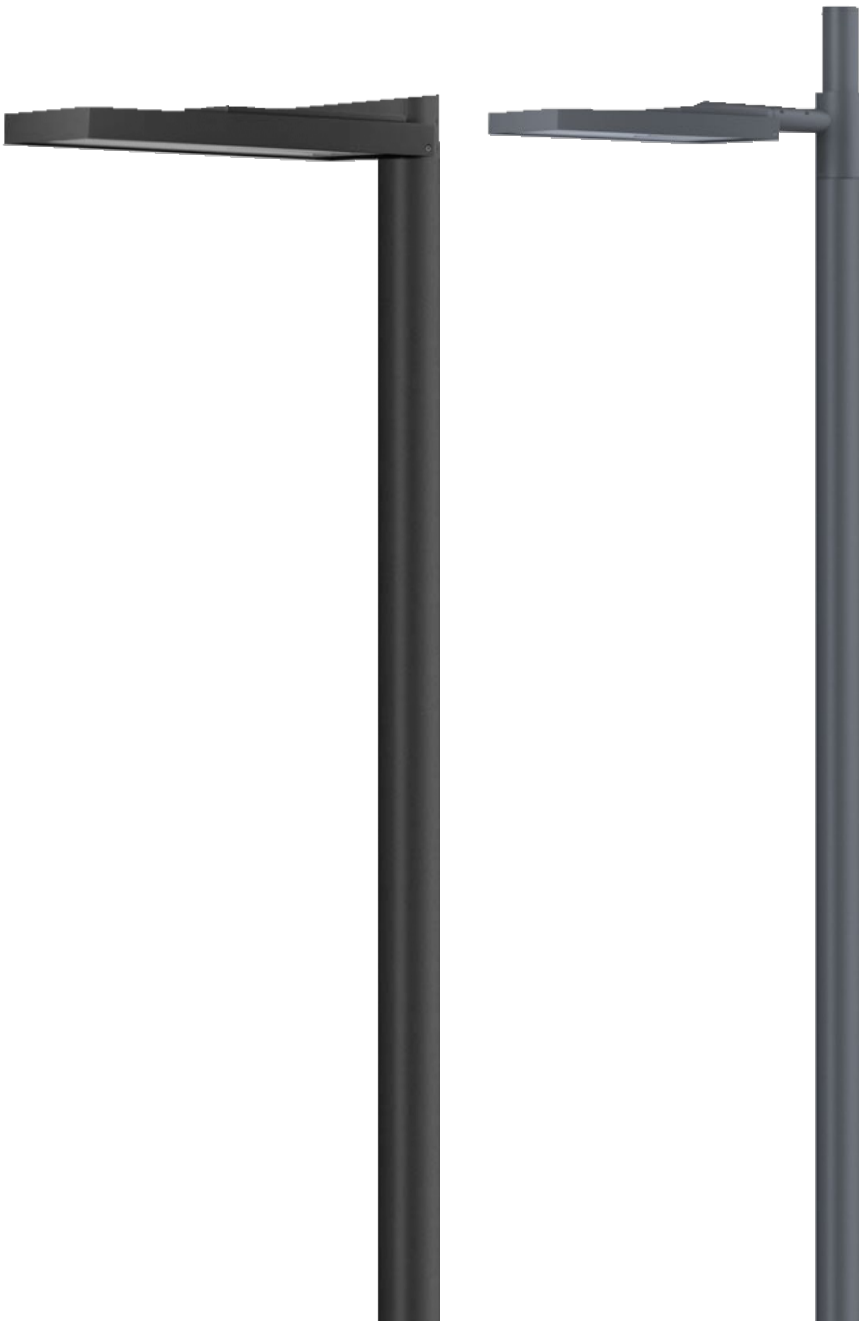



## Post Mounted Luminaires

### Lamps

12 LED 12W / 24 LED 24W / 36 LED 36W / 42 LED 42W\*

12 LED 24W / 24 LED 48W / 36 LED 72W / 42 LED 84W\*

\* Nominal power, for latest data refer to [www.we-ef.com](http://www.we-ef.com)

Protection: IP66, IK08

Class I, II,  $t_a = 25^\circ\text{C}$

Weight: ..... VFL520 ..... max. 4,4 kg  
 ..... VFL530 ..... max. 6,6 kg  
 ..... VFL540 ..... max. 8,4 kg

Windage area: ..... VFL520 ..... max. 0,038 m<sup>2</sup>  
 ..... VFL530 ..... max. 0,040 m<sup>2</sup>  
 ..... VFL540 ..... max. 0,046 m<sup>2</sup>

Installation: horizontal, light output downwards,

Suitable for spigot diameter  $D = 76 \times 80$  mm

Upper pole offset **D1** max. 102 mm

$\varnothing 9 - 14$  mm  1,0 - 2,5 mm<sup>2</sup> 

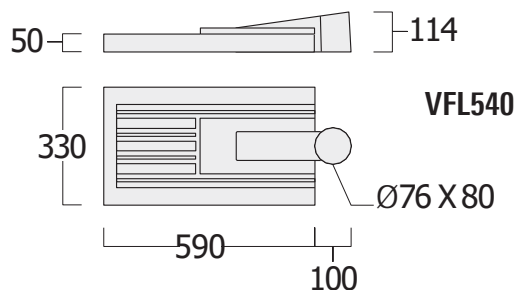
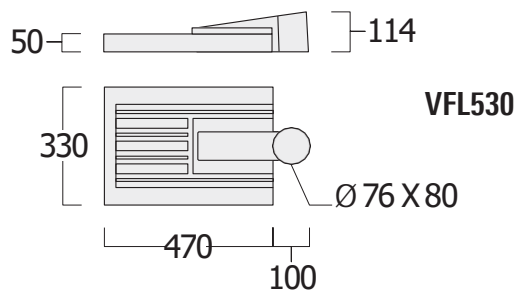
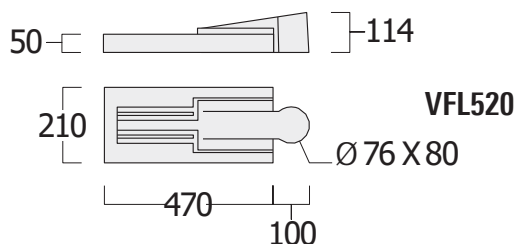

### Tools required

- Screwdriver with 4.0 mm x 1.0 mm blade
- 4 mm Allen key
- diagonal cutting pliers

## Side Entry Mounted Luminaires

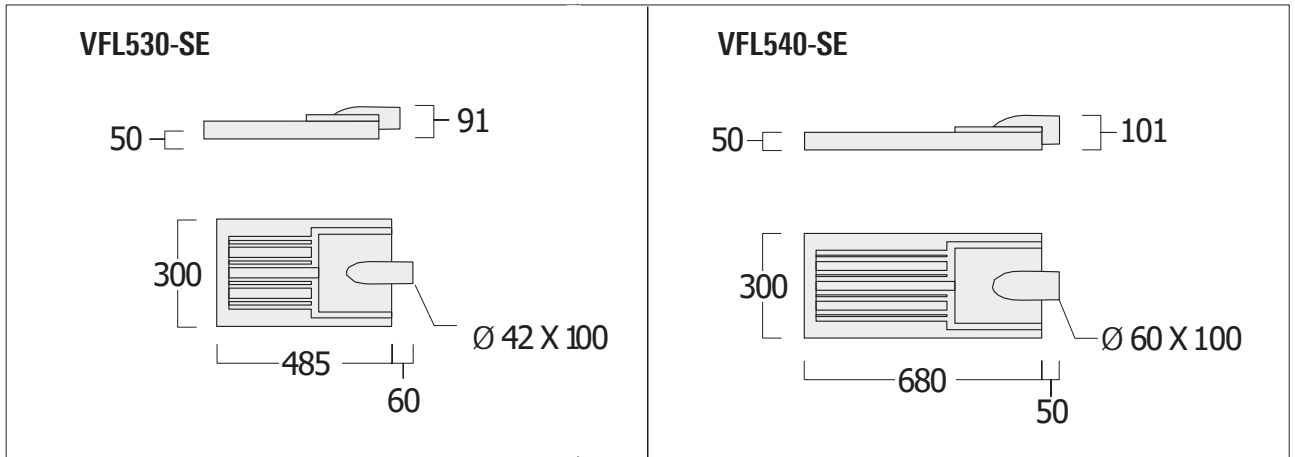

IP66, 240VAC, Class I/Class II,  $t_a = 25^\circ\text{C}$

**Mounting Height** **m**

for VFL530-SE/VFL540-SE 3-8

**Weight** **kg**

for VFL530-SE max. 6.4

for VFL540-SE max. 8.4

**Windage area** **m<sup>2</sup>**

for VFL530-SE max. 0.036

for VFL540-SE max. 0.046

Installation: horizontal, light output downwards

**Light Source**

LED

## Installation

The product must be installed and maintained by a suitably qualified professional in compliance with latest building/construction and/or electrical regulations and relevant legislation

⚡ **Warning:** Switch off mains electrical supply prior to installing and connecting the luminaire.

Do not open luminaire while mains supply is switched on.

**Notice:** If the luminaire is modified by anybody other than the original manufacturer, then the warranty will no longer be valid and shall become the full responsibility of the modifying person/organisation. Claims based on defects attributable to improper installation and/or application, and the consequences thereof, are excluded.

In case of component failure, LED replacement due to abnormal circumstances or at end of life, replacement must be carried out by a suitably qualified and trained professional

**Luminaire pre-wired, do not open**

## Installation Procedure

- 1) Switch off the mains electrical supply. ⚡
- 2) Compare the local voltage with data mentioned on the label of the luminaire packaging, in these instructions and/or marked on the luminaire.
- 3) Pull the supplied and fitted cable **A** through the pole  
**Note: Follow steps 4 & 5 for luminaires fitted with a NEMA cell/Shorting cap, for all others jump to step 6**
- 4) Remove the plastic cap **E** from NEMA cell base.
- 5) Fit PE cell or shorting cap **F** onto NEMA cell base by lining up plugs on PE cell or shorting cap to sockets on NEMA cell base and turning clockwise to lock in place.
- 6) Attach the luminaire onto the pole or bracket **D** and tighten the fixing screws **B**, tightening to a torque of 5Nm.  
For SE side entry versions place luminaire onto horizontal spigot and tighten the fixing screws **B**.
- 7) Unless ordered with an internal SPD, the flex must be connected to the terminals of the provided remote SPD behind the door at the base of the pole as per the SPD Installation Instructions.

## Disassembly

- 8) Reversal of assembly

## Maintenance

Apart from cleaning the outside of the luminaire, no special maintenance is necessary.

Clean only with a cloth and water

**Do not use high pressure washers**

VFL500 Post Top

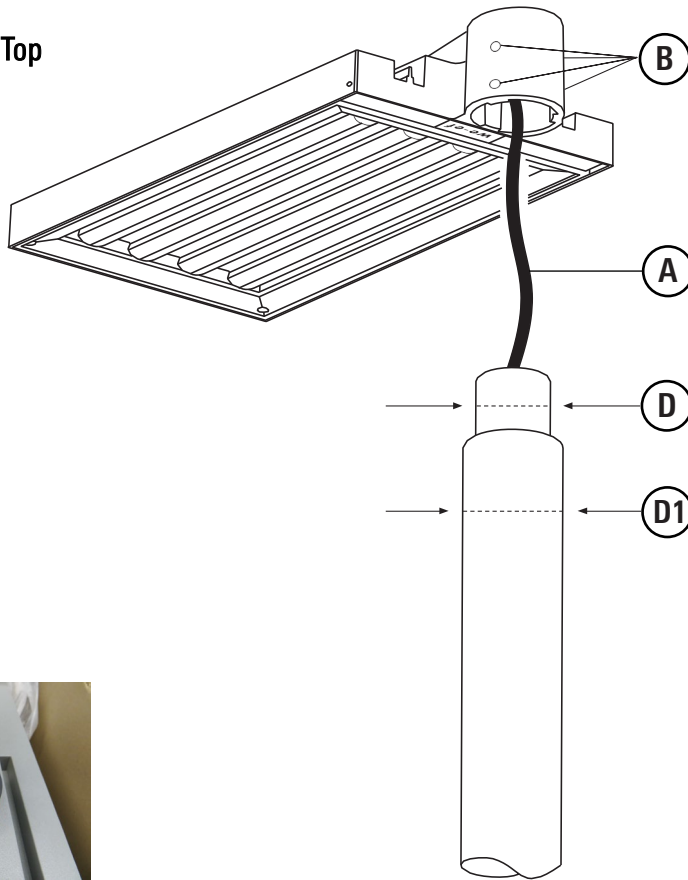

E

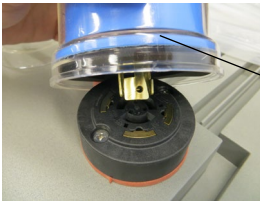

F

VFL500-SE Side Entry

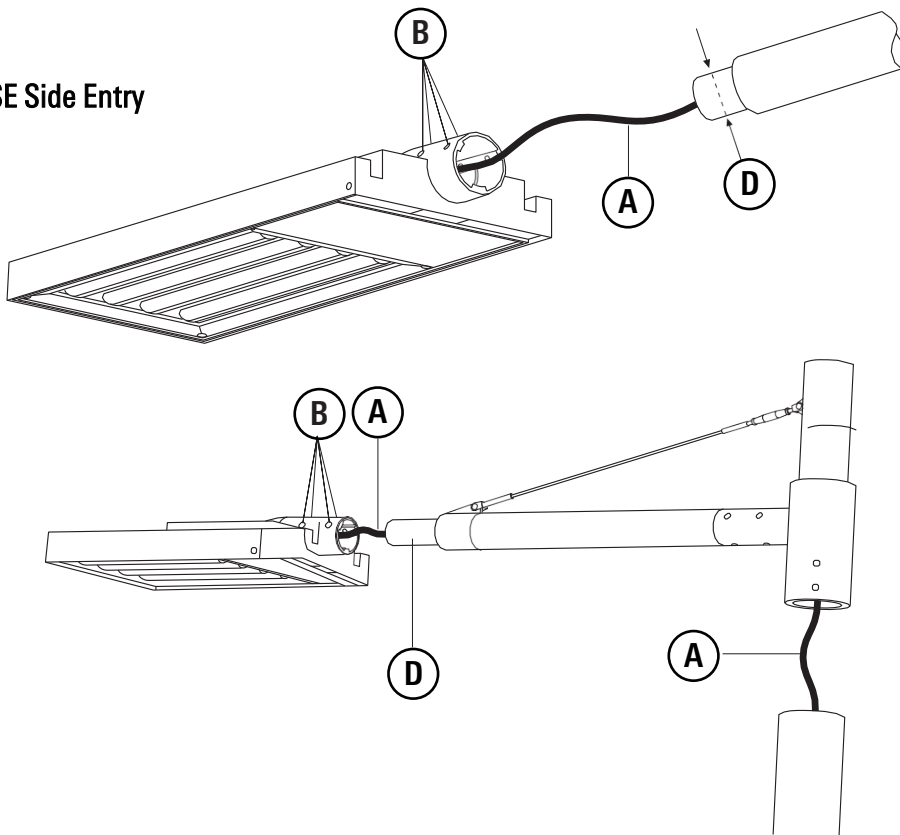



# **we-ef**

[www.we-ef.com](http://www.we-ef.com)

## **WE-EF LEUCHTEN**

Germany

Tel +49 5194 909 0

Fax +49 5194 909 299

[info.germany@we-ef.com](mailto:info.germany@we-ef.com)

## **WE-EF LUMIERE**

FRANCE

Tel +33 4 74 99 14 44

Fax +33 4 74 99 14 40

[info.france@we-ef.com](mailto:info.france@we-ef.com)

## **WE-EF HELVETICA**

Switzerland

Tel +41 22 752 49 94

Fax +41 22 752 49 74

[info.switzerland@we-ef.com](mailto:info.switzerland@we-ef.com)

## **WE-EF ILLUMINAZIONE**

Italy

Tel +39 029 0092354

[info.italy@we-ef.com](mailto:info.italy@we-ef.com)

## **WE-EF LIGHTING**

United Kingdom

Tel +44 844 880 5346

Fax +44 844 880 5347

[info.uk@we-ef.com](mailto:info.uk@we-ef.com)

## **WE-EF LIGHTING**

United States of America

Tel +1 724 742 0030

Fax +1 724 742 0035

[info.usa@we-ef.com](mailto:info.usa@we-ef.com)

## **WE-EF LIGHTING**

Thailand

Tel +66 2 738 9610

Fax +66 2 175 2174

[info.asiapacific@we-ef.com](mailto:info.asiapacific@we-ef.com)

## **WE-EF LIGHTING**

Australia

Tel +61 3 8587 0444

Fax +61 3 8587 0499

[info.australia@we-ef.com](mailto:info.australia@we-ef.com)

VFL500 Series LED © WE-EF 2015

Technical specifications are  
subject to change.

