

ATTENTION
THE WARRANTY SHALL BE VOID IF INSTALLATION OF THE PRODUCT IS NOT PERFORMED IN ACCORDANCE WITH WE-EF LIGHTING'S INSTALLATION INSTRUCTIONS

Blockout Installation Procedure (ETC300 SERIES)

- 1) Ensure that proper drainage is provided for the shown installation methods:
 - a) In landscape/paved areas, sand or concrete with gravel base (Fig. I).
 - b) With fully concreted installation, drainage piping must be provided (Fig. II).

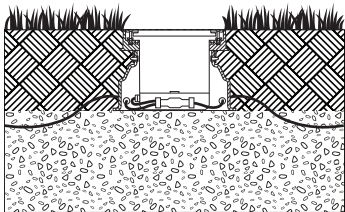

Fig. I

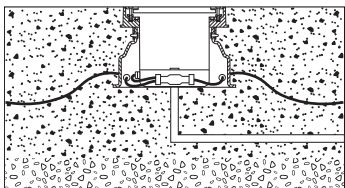
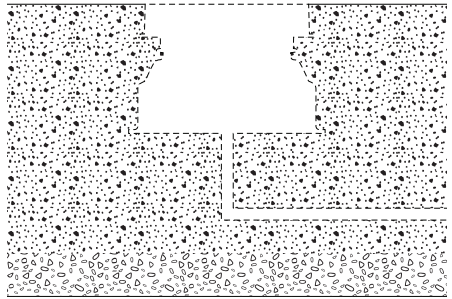

Fig. II

- 2) Ensure a suitable recess.



- 3) Test drainage (ensure water drains within 30 mins, **Warning:** warranty void if luminaire installed without appropriate drainage)

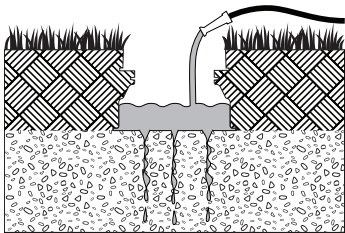

Fig. I

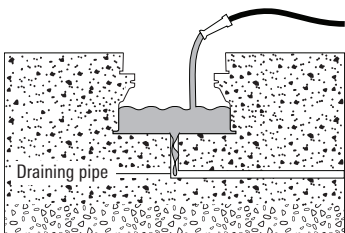
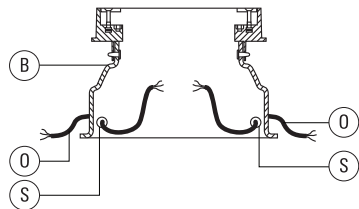
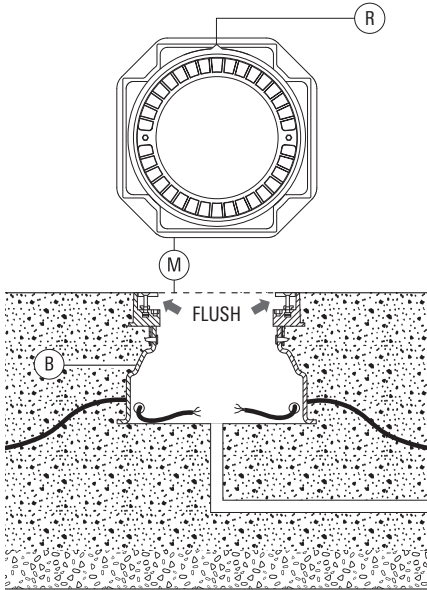

Fig. II

- 4) Select appropriate installation blockout holes **S** for mains supply cable(s) **O** and data cable(s) if necessary.



- 5) Set mounting ring **B/M** in position. Arrow **R** on mounting ring **M** is pointed towards the object to be illuminated (wall, tree, column).



- 6) Replace blackout cover **Z** prior to luminaire installation to prevent tripping hazard and concrete or dirt from getting into blackout.

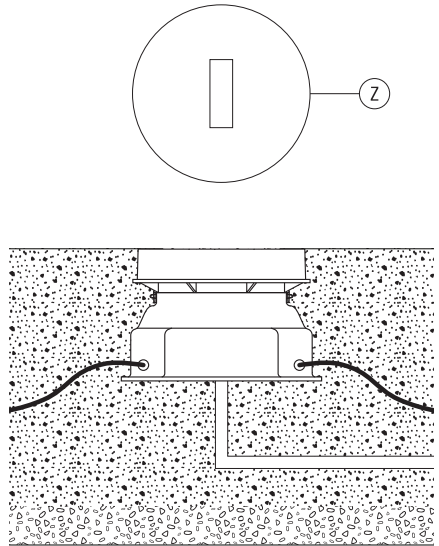

- 7) Framing should be installed to prevent vegetation from growing over the lens. Contact our installer hotline for any further installation related enquiries.

