

Description

IP66. Class I. IK07. Marine-grade, die-cast aluminum alloy. 5CE superior corrosion protection including PCS hardware. Silicone CCG® Controlled Compression Gasket. Safety glass lens. Includes 1 ft of flexible cable enclosed in a stainless conduit, in-line connector and mounting clamp for installation to RAIL66 mounting system. CAD-optimized optics for superior illumination and glare control. Integral driver in thermally separated compartment. OLC® One LED Concept. Factory-installed LED circuit board. 0-10V Dimming comes standard with luminaire.

Knuckle permits 350° horizontal and 90° vertical aiming of optics.

Specify product with 7 Digit product code - Finish Color. Accessories, such as mounting, optical, and electrical, must be specified separately.

Example: XXX-XXXX-9004 (Black)
+ XXX-XXXX (Accessory 1)

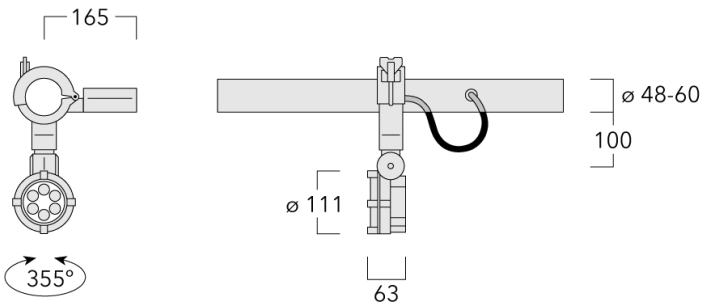

Specifications

Material description

Body	Marine-grade die-cast aluminium alloy			
Lens	Clear tempered glass lens			
Colors	RAL9004	RAL9016	RAL8019	RAL9007
	Signal black	Traffic white	Grey brown	Grey aluminium
Gasket	Silicone rubber gasket			
Fasteners	PCS Polymer Coated Stainless Steel hardware			
Ingress protection	IP66			
Impact resistance	IK07			
Corrosion resistance	5CE			

Electrical description

Power supply	Integral [ECG] electronic driver 120V-277V. 0-10V dimmable, to be specified with order.
Driver / Ballast	Integral EC electronic converter in thermally-separated compartment
Surge protection	1/2 kV
Energy efficiency	C-D (Light source)

Additional information

Listings	ETL listed. Suitable for wet locations.
Lifetime	Ta=25°/40° L90B10 > 90000h

Options

Light distribution

Color temperature

Nominal Watt



[M] symmetric, medium beam

0 W



[VNS] symmetric, very narrow beam, sharp cut-off





[W] bi-symmetric, wide beam



[VN] symmetric, very narrow beam

Configurations

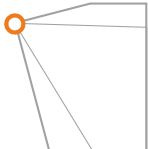
Light distribution	Part ID	Light source	Delivered lumens	Rated input power	CRI
	145-0043_us		1511.8 lm	0 W	80
	145-0044_us		1616.1 lm	0 W	80
	145-0298_us		1407.5 lm	0 W	80
[M] symmetric, medium beam					
	145-0091_us		1496.5 lm	0 W	80
	145-0092_us		1599.7 lm	0 W	80
	145-0299_us		1393.3 lm	0 W	80
[VN] symmetric, very narrow beam					
	145-0046_us		1610.7 lm	0 W	80
	145-0047_us		1721.8 lm	0 W	80
	145-0300_us		1499.6 lm	0 W	80
[VNS] symmetric, very narrow beam, sharp cut-off					
	145-0088_us		1347.1 lm	0 W	80
	145-0089_us		1440 lm	0 W	80
	145-0297_us		1254.2 lm	0 W	80
[W] bi-symmetric, wide beam					