





**Description**

IP66, Class I. IK07. Marine-grade, die-cast aluminium alloy. 5CE superior corrosion protection + primer including PCS hardware. Safety glass lens. Silicone CCG® Controlled Compression Gasket. Luminaire is factory-sealed and does not need to be opened during installation.

Integral EC electronic converter in thermally-separated compartment. Advanced thermal management protects LEDs while optimising lumens output. CAD-optimised optics for superior illumination and glare control. OLC® One LED Concept.

Including 0.4 m of flexible cable enclosed in a stainless conduit, in-line connector and mounting clamp for installation to RAIL66 mounting system.

If ordering a fitting to be installed on an existing rail, please confirm the rail version with your local distributor or our customer excellence team as connectors vary.

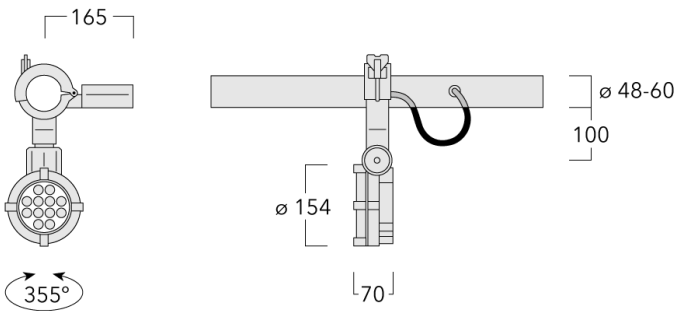

## Specifications

### Material description

Body	Marine-grade die-cast aluminium alloy		
Lens	Safety glass lens		
Colours	<b>RAL9004</b>	<b>RAL9006</b>	<b>RAL9007</b>
	Signal black	White aluminium	Grey aluminium
Gasket	Silicone CCG® Controlled Compression Gasket		
Fasteners	PCS Polymer Coated Stainless Steel Hardware (unpainted)		
Ingress protection	IP66		
Impact resistance	IK07		
Corrosion resistance	5CE+Primer		

### Electrical description

Power supply	230V / 50 Hz
Driver / Ballast	Integral EC electronic converter in thermally-separated compartment
Surge protection	1/2 kV
Energy efficiency	The product is supplied with 10-year warranty. Please refer to the LED Warranty Statement located on <a href="http://www.we-ef.com">www.we-ef.com</a> for further details.

### Additional information

Lifetime	Ta=40° L90B10 > 90000h
----------	------------------------

**Options**

**Light distribution**

**Colour temperature**

**Nominal Watt**



[M] symmetric, medium beam



3000K

24 W



[EES] symmetric, very narrow beam, sharp cut-off

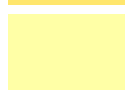

4000K

RGBW



[B] symmetric, wide beam







2700K



[EE] symmetric, very narrow beam

## Configurations

Light distribution	Part ID	Light source	Rated lumens	Rated input power	CRI
 [B] symmetric, wide beam	146-0980	LED-12/24W/2700K	2522.3 lm	24 W	80
	146-0530	LED-12/24W/3000K	2709.2 lm	24 W	80
	146-0531	LED-12/24W/4000K	2896 lm	24 W	80
	146-8365	LED-12/24W/RGBW	1318.9 lm	24 W	80
 [EE] symmetric, very narrow beam	146-0982	LED-12/24W/2700K	2684.8 lm	24 W	80
	146-0533	LED-12/24W/3000K	2883.7 lm	24 W	80
	146-0534	LED-12/24W/4000K	3082.5 lm	24 W	80
	146-8363	LED-12/24W/RGBW	1461.3 lm	24 W	80
 [EES] symmetric, very narrow beam, sharp cut-off	146-0983	LED-12/24W/2700K	2865.6 lm	24 W	80
	146-0414	LED-12/24W/3000K	3077.9 lm	24 W	80
	146-0415	LED-12/24W/4000K	3290.2 lm	24 W	80
 [M] symmetric, medium beam	146-0981	LED-12/24W/2700K	2791.8 lm	24 W	80
	146-0411	LED-12/24W/3000K	2998.6 lm	24 W	80
	146-0412	LED-12/24W/4000K	3205.4 lm	24 W	80
	146-8364	LED-12/24W/RGBW	1599.4 lm	24 W	80